

English

HP Mopier 320 System
Service Manual

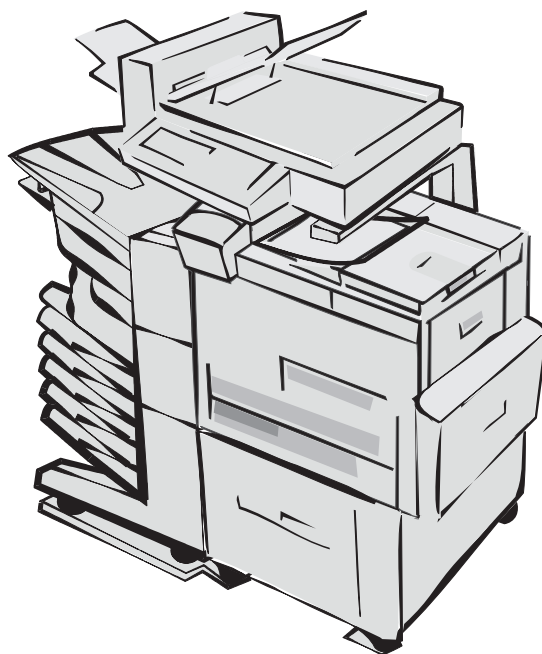

HP Mopier 320 System
Service Manual

Service Manual

HP Mopier 320 System Service Manual

© Copyright
Hewlett-Packard Company 1998
All Rights Reserved.
Reproduction, adaptation, or
translation without prior written
permission is prohibited, except
as allowed under the copyright
laws.
Publication number
C4229-90911
First edition, October 1998

Trademark Credits

Adobe and PostScript are
trademarks of Adobe Systems
Incorporated which may be
registered in certain
jurisdictions.

Windows is a U.S. registered
trademark of Microsoft
Corporation.

Warranty

The information contained in
this document is subject to
change without notice.

Hewlett-Packard makes no
warranty of any kind with regard
to this material, including, but
not limited to, the implied
warranties or merchantability
and fitness for a particular
purpose.

Hewlett-Packard shall not be
liable for errors contained herein
or for incidental or
consequential damages in
connection with the furnishing,
performance, or use of this
material.

WARNING

Electrical Shock Hazard

To avoid electrical shock, use
only supplied power cords and
connect only to properly
grounded wall outlets.

Conventions

This manual uses the following conventions:

The names of major printer parts and assemblies are Capitalized.

Color is used to emphasize items which are important to the material under discussion.

Bold is used for emphasis, particularly in situations where *italic* type would be confusing.

Italic type is used to indicate related documents or emphasis.

Note

Notes contain important information set off from the text.

CAUTION

Caution messages alert you to the possibility of damage to equipment or loss of data.

WARNING!

Warning messages alert you to the possibility of personal injury.

The illustration below shows the orientation of the paper-handling accessories as they are referred to in this publication.

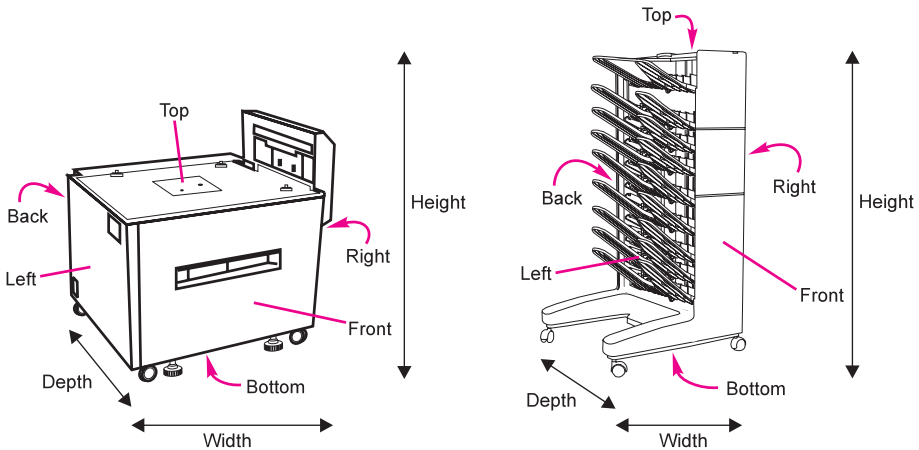

Chapter Descriptions

1 Product Information

Contains printer features and product overview, tray capacities and sizes, media specifications, how to get technical assistance, and required safety and compliance statements.

2 Site Requirements

Contains space and environmental requirements.

3 Operating Overview

Contains details about control panel menus, restoring factory defaults, and resetting and testing the printer.

4 Maintenance and Adjustments

Contains cleaning and preventive maintenance information, and adjustment procedures for all paper trays.

5 Functional Overview

Contains block diagrams and basic theory of operation for the printer systems, paper paths, and paper handling devices. Contains basic cabling information.

6 Removal and Replacement

Contains step-by-step procedures for replacing field replaceable units (FRUs) in the printer and paper-handling devices.

7 Troubleshooting

Contains a preliminary troubleshooting table, a table with descriptions and recommended actions for all control panel messages, image defect samples, paper handling problems, service approach, and troubleshooting checks and tools.

8 Parts and Diagrams

Contains exploded view drawings and part number listings for all replaceable parts in the printer and paper-handling devices.

Contains two replaceable parts tables: one sorted alphabetically by part name, and one sorted numerically by part number. Both tables are cross referenced to the diagrams in the chapter.

Subject Index

Contains an alphabetical, cross referenced listing of information found in the main body of the manual.

Table of Contents

List of Figures

List of Tables

1 Product Information

Features of the HP Digital Copy 320	2
Features of the Mopier	2
Features of the Copy Module	4
Product Overview	5
External View of Mopier	5
Formatter Assemblies	7
External View of HP Digital Copy 320	8
Configurations	9
Paper Capacities and Sizes	11
Mopier and Paper-handling Devices	11
Mopier Media Selection Guidelines	13
Paper	13
Envelopes	13
Adhesive Labels	14
Transparencies	15
Storing Print Media	15
Shipping Print Media	15
Copy Module Media Selection Guidelines	17
Paper Specifications	17
Paper Size	17
Paper Conditions	18
Document Quality	18
Identification	22
Model and Serial Numbers	22
Paper-handling Devices, Accessories, and Options	23
Ordering Information	24
Hard Disk	30
Determining Memory Requirements	30
Technical Assistance	32
HP FIRST (Fax Information Retrieval Support Technology)	32
Internet	33
World Wide Web	33
HP Reseller Sales and Service Support Line (US Only)	33
Other Areas	33

Regulatory Information34
FCC Regulations.34
Environmental Product Stewardship.35
Material Safety Data Sheet.37
Environmental Conformity.38
Declarations of Conformity39
Safety Statements.42

2 Site Requirements

Operating Environment46
Space Requirements47
Environmental Requirements50
Specifications51
Mopier and Paper-handling Devices.51
Copy Module.55

3 Operating Overview

HP Mopier 320

Using the Mopier Control Panel58
Control Panel Layout58
Indicator Lights59
Settings and Defaults60
Printer Driver Information60
Paper Source Default61
Performing a Cold Reset.62
Setting the Display Language.62
Control Panel Menus.65
Quick Copy Jobs Menu.66
Private/Stored Jobs Menu.66
Information Menu67
Paper Handling Menu.68
Print Quality Menu70
Printing Menu72
Configuration Menu.75
I/O Menu80
EIO Menu82
Resets Menu.84
Mopier Service Mode85
Setting Page Count, Maintenance Count, and Serial Number87
Setting the Cold Reset Default Paper Size.88
Testing the Mopier.89
Paper Path Test89
Configuration Page89

HP Digital Copy 320

Using the HP Digital Copy 320 Front Panel90
HP Digital Copy 320 Front Panel91
HP Digital Copy 320 Settings100
Loading documents into the ADF102
Loading documents onto the Flatbed104
Copy Module Service Mode105
HP Resource Manager107
Accessing the HP Resource Manager107
Downloading Copy Module Firmware108

4 Maintenance and Adjustments

HP Mopier 320

Cleaning the Mopier and Accessories112
Cleaning the Mopier113
Cleaning Spilled Toner114
Preventive Maintenance115
Tray Adjustment Procedure116
2000-sheet Input Tray Adjustment Procedure118

HP Digital Copy 320

Cleaning the HP Digital Copy 320120
Materials120
Vacuum Specifications120
Cleaning ADF and Glass121
Cleaning the Document Cover, Document Holder, and Flatbed Glass121
Cleaning the ADF122
Complete Optics Cleaning124
Cleaning the ADF Lamp and Mirrors124
Lubricating the ADF Gears124
Cleaning the Carrier Unit and Mechanical Assemblies125
Lubricating the Carrier Unit Shaft125
Lubricating the Top of the Carrier Guide Rail125
Lubricating the Flatbed Motor Gears125
Cleaning the Front Panel125
Maintaining the HP Digital Copy 320126
HP Digital Copy 320 Maintenance Parts126
Calibrating the HP Digital Copy 320126
Types of Calibration126
When to Calibrate127
Calibration Target127
Entering the Calibration Menu in Service Mode127
How to Perform an Offset Adjustment Calibration128
How to Perform a Density Calibration Adjustment128
How to Perform an ADF Vertical Magnification Adjustment128

5 Functional Overview

HP Mopier 320

Printer Functional Block Diagram	130
Power Distribution System	131
AC Power Distribution	132
Overcurrent/Overvoltage Protection	132
High Voltage Power Distribution	133
Formatter System	134
DC Controller System	137
Laser and Scanner Drive	137
Paper Motion Monitoring and Control	137
Clutches	137
Engine Test Microswitch	138
Motors	138
Image Formation System	139
Toner Cartridge	140
Drum Cleaning	142
Drum Conditioning	143
Image Writing	144
Image Developing	146
Image Transferring and Media Separation	148
Image Fusing	149
Paper Paths and Components	150
Printer, Duplexer, and Envelope Feeder	150
Paper Size Switches (Trays 2 and 3)	153
Printing from Tray 1	153
Printing from Trays 2 and 3	153
Printing from the Envelope Feeder	154
Printing with the Duplexer	154
2000-sheet Input Tray (Tray 4) Components	155
2000-Sheet Input Tray Operation	157
2 x 500-sheet Input Tray	160
2 x 500-sheet Input Tray Operation	162
7-bin Tabletop Mailbox Components	164
7-bin Tabletop Mailbox Operation	166
8-bin Mailbox Components	170
8-bin Mailbox Operation	173
Finisher Components	175
Stapler Unit Operation	177
Main Functional Cycles of the Stapler (Internal Paper Path)	179
Communication Link (Daisy Chain)	180
Paper Jam Detection	182
Printer Timing	182
IEEE 1284 Parallel Cable Information	184

HP Digital Copy 320

Copy Module Functional Overview	185
Copy Module System	185
Function and Layout of the Copy Processor.	187
Power Up Process.	189
Copy Processor Board	189
Copy Module.	191
Mopier.	192
Notes About the HP Mopier 320 Product ID.	192
ADF Simplex Operation.	193
ADF Duplex Operation	194
Flatbed Operation	194
Image Path	196
Communication to the Mopier	198
Communication Channels.	198
Print Job Interrupt	198
Paper Path and Sensors.	199

6 Removal and Replacement

Removal and Replacement Strategy.	202
Electrostatic Discharge (ESD) Precautions	202
Required Tools	203
User Installable Accessories	204
Memory and Personality Upgrade	204
Duplexer	206
Envelope Feeder.	206
2000-sheet or 2 x 500-sheet Input Tray	207
8-bin Mailbox/5-bin Mailbox with Stapler	208
7-bin Tabletop Mailbox	209
Hardware Table.	212

HP Mopier 320

Engine Removal and Replacement.	214
Control Panel	215
Covers.	217
Delivery Unit (for Face-down Bin).	226
Diverter Assembly.	229
Diverter Door Assembly	230
Lower Right Door Assembly	231
Fan 1, Laser/Scanner and Housing (Exhaust)	234
Fan 2, Low Voltage Power Supply (Exhaust)	236
Fan 3, Formatter Fan and Housing (Intake)	237
Fan 4, Delivery Unit (Exhaust)	238
Fan 5, Tray 1 (Intake).	239
Tray 1	241
Tray 1 Pickup Assembly	244

Engine Removal and Replacement (continued)	
Feeder Assembly248
Formatter Assembly250
Fusing Assembly.252
Laser/Scanner Assembly254
Main Gear Assembly.256
Main Motor Assembly259
Paper Input Unit (PIU).260
PCA, DC Controller.261
Output Paper Sensor PCA262
High Voltage Power Supply (HVPS).269
Low Voltage Power Supply (LVPS)270
Registration Assembly271
Tray 1 Feed Roller and Separation Pad274
Tray 2 and 3 Pickup, Feed, and Separation Rollers276
Paper Input Unit Sensor (PS2)277
Registration Sensor (PS1)279
Face-up Solenoid Assembly (SL3)281
Transfer Roller Assembly282
Tray 2 and 3 Assemblies284

Paper-handling Devices

2000-sheet Input Tray Removal and Replacement.285
Orientation286
Front Cover287
Back Cover288
Left Cover289
Right Cover290
Main Drive Assembly291
Paper Tray293
Main Cable Harness294
Controller PCA296
Front LED PCA Assembly.298
Pickup Assembly.300
Power Supply302
Pickup, Feed, and Separation Rollers304
Paper Quantity Switch Assembly306
Paper Size Switch Assembly306
Vertical Transfer Unit (VTU)308
Tension Springs310
Locating Pins311
Casters and Stabilizing Feet.312
Adjustable Foot.313

2 x 500-sheet Input Tray Removal and Replacement	314
Orientation of the 2 x 500-sheet Input Tray	315
Back Cover	316
Left Cover	317
Vertical Transfer Unit (VTU)	318
Right Cover	321
Front Top Cover	324
Trays 4 and 5	327
Pickup Assembly	329
Paper Deck Drive Assembly	331
Pickup, Feed, and Separation Rollers	333
Controller PCA	334
Tray-Size Sensing PCA	335
Power Supply	337
Main Cable	338
Storage Paper Tray	340
Front Door (Storage Area)	341
Casters	342
Foot Tip and Adjustable Foot Tip (Stabilizing Feet)	343
2 x 500-sheet Input Tray Removal and Replacement	
Locating Pins	344
Front LED PCA	345
7-bin Tabletop Mailbox Removal and Replacement	347
Orientation of the 7-bin Tabletop Mailbox	348
Front Cover	349
Back Cover	352
Top Cover	354
Controller PCA	358
Power Supply	359
Right Door Assembly (Paper Path Cover)	360
Face-down Bins	364
Empty Bin Sensor PCA	367
Full Bin and Interlock Sensor PCA	369
LED PCA	371
Face-up Sensors PCA	372
Reversing Mechanism Motor	373
Face-up/Diverter Assembly (Flipper)	375
Short Tray 7	378
Solenoid Reversing Mechanism	379
Flipper Solenoid	380
Handle	381
Latching Mechanism	382
Cover Latch	383

8-bin Mailbox Removal and Replacement	384
Orientation	385
Front and Back Covers	386
Top Cover	387
Power Supply	388
Paper Bins and Blind Cover	389
Flipper Assembly	390
Delivery Head Motor	393
Transport Belt Motor	394
Input Paper Guide	396
Metal Tape and Housing Assembly	398
Controller PCA	400
Anticurl Strings	402
Delivery Head Assembly	404
Interlock Switch	409
Diagnostic LED PCA	410
User Status LED PCA	412
Adjustable and Fixed Casters	414
Attachment Assembly	415
Stapler Assembly Removal and Replacement	416
Mailbox with Stapler, Stapler Removal or Installation	417
Back Plate	419
Stapler Controller PCA	421
Top Cover Assembly	424
Stapler Bed Assembly	425
Hinges	427
HP Digital Copy 320	
HP Digital Copy 320 Removal and Replacement	429
Installing the HP Digital Copy 320	430
Install the HP Digital Copy 320 on the Optional HP Digital Copy 320 Stand	430
Install the Mopier on the Optional Input Accessory	432
Roll the Mopier onto the Optional HP Digital Copy 320 Stand	432
Install the Optional Output Accessory	433
Install the Copy Connect EIO Board into the Mopier	434
Install the Copy Connect Cable	435
Install the Y Power Cord	436
Hardware Table	437
Orientation of the HP Digital Copy 320	439
Copy Module Maintenance Parts	440
Separation Pad Assembly	440
Pick Roller Assembly	441

Copy Module Skins445
Document Holding Pad445
Paper Chute Flip-out446
Output Tray Flip-out447
Output Tray447
Flatbed (FB) Cover Assembly448
ADF Latch Cap451
ADF Cover452
Front Panel454
Panel Cover459
Front Panel Brackets460
Upper Cover462
Copy Module Power Supply/Main Board Assemblies464
Copy Processor Board464
Power Supply and Main Board Tray465
RFI Cover467
Control PCA469
Fan472
Power Supply473
Back PCA474
Copy Module ADF Unit Assemblies475
Optical Unit475
ADF Lamp PCA477
ADF Lamp479
Sensor Unit Assembly480
ADF Motor Unit483
ADF Belt484
LED Assembly PCA486
ADF Unit487
Copy Module Flatbed Assemblies488
Front Panel Frame Ground Spring488
Output Tray Brackets489
Glass Plate Assembly490
Home Position Sensor492
Carrier Unit Lamp494
Carrier Unit497
Felt Pad501
Feet502
Frame Ground Spring503
Front Lamp PCA504
Junction PCA and Cover505
Front Panel Ribbon Cable507
Carrier Belt and Motor509

7 Troubleshooting

Service Approach	512
Ordering Parts	512
Exchange Program	513
Consumables	513
Toner Cartridge Life	513
Refilled Toner Cartridges and Non-HP Staple Cartridges	514
Recycling Toner Cartridges	514
Troubleshooting Process	515
Mopier System Troubleshooting Process	517
Mopier/Paper-Handling Troubleshooting Process	518
Copy Module Troubleshooting Process	520
HP Mopier 320	
Troubleshooting the Mopier System	522
Preliminary Operating Checks	522
Communication	523
Interface Troubleshooting	523
Network Troubleshooting	525
Verify Host System Operation	527
Verify Network and Server Operation	527
General Troubleshooting Information	528
Miscellaneous Problems and Solutions	528
Paper Curl	533
Troubleshooting the Mopier and Paper-handling Devices	534
Step 1 Power On	534
Engine Test	537
Step 2 Display	538
Event Log	538
Step 3 Printer and Paper-Handling Devices Messages	542
Printer Message Tables	544
Engine Error Messages	545
Input Device Messages	557
Output Device Messages	565
Finisher Devices Messages	576
Paper Handling Controller Error Messages	580
Step 4 Paper Path Troubleshooting	581
Paper Jams	582
Paper Path Test	584
Step 5 Information Pages	587
Menu Map	587
Configuration Pages	589
File Directory Page	592
Usage Page	593
Step 6 Image Quality	597
Check the Toner Cartridge	598

Troubleshooting the Mopier and Paper-handling Devices (continued)	
Image Quality Tables599
Repetitive Defect Ruler612
Image System Troubleshooting614
High-Voltage Power Supply Check615
Self-Diagnostics on Paper-handling Devices617
2000-sheet Input Tray Stand-alone Diagnostics617
2 x 500-sheet Input Tray Standalone Diagnostics621
7-bin Tabletop Mailbox Standalone Diagnostics625
8-bin Mailbox Stand-alone Diagnostics630
Diagrams638

HP Digital Copy 320

Troubleshooting the HP Digital Copy 320651
Step 1 Power On652
Step 2 Display and Communication653
Step 3 Error Messages and Problems654
Status Messages654
Step 4 Information Pages659
Step 5 Paper Path660
Step 6 Image Quality661
Testing the HP Digital Copy 320664
Copy Processor LED Test664
Copy Module Boot Up Icon Conditions666
Copy Module Offline Test667
Other Tests669
Service Mode Tests671

8 Parts and Diagrams

How to Use the Part Lists and Diagrams674
Ordering Parts674
Common Hardware674
Illustrations and Parts Lists675

HP Mopier 320

Mopier and Paper-handling Components676
Printer Parts and Diagrams680
Paper-Handling Devices Parts and Diagrams694
Input Devices694
Output Devices702
Alphabetical Parts List (Mopier and Paper Handling Devices)714
Numerical Parts List (Mopier and Paper Handling Devices)724

HP Digital Copy 320

HP Digital Copy 320 Parts and Diagrams735
Alphabetical Parts List (Copy Module)750
Numerical Parts List (Copy Module)754

Index

List of Figures

Figure 1-1	Copy System - - - - -	2
Figure 1-2	Mopier - Front and Right Side View with Tray 1 Open - - - - -	5
Figure 1-3	Rear and Left Side View - - - - -	7
Figure 1-4	Front view of HP Digital Copy 320- - - - -	8
Figure 1-5	Rear view of HP Digital Copy 320 - - - - -	8
Figure 1-6	Preferred Configuration - - - - -	9
Figure 1-7	Tabletop Configuration - - - - -	10
Figure 1-8	Paper size specification - - - - -	17
Figure 1-9	Paper orientation - - - - -	20
Figure 1-10	Areas of the Paper that Should Not Be Perforated - - - - -	21
Figure 1-11	Sample Model and Serial Number Label for the Mopier - - - - -	22
Figure 1-12	Paper Handling Devices - - - - -	23
Figure 2-1	Mopier Space Requirements (Top view) - - - - -	47
Figure 2-2	Mopier Space Requirements (Side view) - - - - -	47
Figure 2-3	Mopier Space Requirements (with Mailbox and Input Device) - - - - -	48
Figure 2-4	Mopier and Copy Module Space requirements- - - - -	49
Figure 2-5	Dimensions of Paper Handling Devices - - - - -	53
Figure 3-1	Control Panel Layout - - - - -	58
Figure 3-2	Front Panel Layout - - - - -	91
Figure 3-3	Button/LED Functions- - - - -	98
Figure 3-4	Copy Module Service Mode - - - - -	105
Figure 3-5	HP Resource Manager (1 of 2) - - - - -	108
Figure 3-6	HP Resource Manager (2 of 2) - - - - -	109
Figure 4-1	Image Area Margins - - - - -	116
Figure 4-2	Tray Position Adjustment - - - - -	117
Figure 4-3	Tray 4 Position Adjustment - - - - -	118
Figure 4-4	Cleaning the Document Cover, Document Holder, and Flatbed Glass - - - - -	121
Figure 4-5	Parts of the ADF - - - - -	122
Figure 4-6	Creating an Offset Target - - - - -	127
Figure 5-1	Printer Functional Block Diagram - - - - -	130
Figure 5-2	Low Voltage Power Distribution System - - - - -	131
Figure 5-3	Low Voltage Power Supply - - - - -	132
Figure 5-4	High Voltage Power Supply Contacts - - - - -	133
Figure 5-5	Normal Mode vs EconoMode - - - - -	136
Figure 5-6	Image Formation Block Diagram - - - - -	139
Figure 5-7	Photosensitive Drum - - - - -	141
Figure 5-8	Drum Cleaning - - - - -	142
Figure 5-9	Primary Charging Roller- - - - -	143
Figure 5-10	Image Writing- - - - -	144
Figure 5-11	Image Development - - - - -	147

Figure 5-12	Image Transferring and Media Separation - - - - -	148
Figure 5-13	Image Fusing - - - - -	149
Figure 5-14	Printer Paper Paths - - - - -	150
Figure 5-15	Printer Sensors, Solenoids, Clutches, Motors, and Fans - - - - -	152
Figure 5-16	2000-sheet Input Tray Paper Path- - - - -	155
Figure 5-17	2000-sheet Input Tray Sensors, Switches, Clutches, and Motors -	157
Figure 5-18	2 x 500-sheet Input Tray Paper Path - - - - -	160
Figure 5-19	2 x 500-sheet input Tray Sensors and Switches - - - - -	161
Figure 5-20	7-bin Tabletop Mailbox Components (1 of 2)- - - - -	164
Figure 5-21	7-bin Tabletop Mailbox Components (2 of 2)- - - - -	165
Figure 5-22	7-bin Tabletop Mailbox Block Diagram- - - - -	169
Figure 5-23	8-bin Mailbox Paper Path - - - - -	170
Figure 5-24	8-bin Mailbox Sensors, Switches, Motors, and Controller PCA - -	172
Figure 5-25	Finisher Paper Path- - - - -	176
Figure 5-26	Stapler Motors, Sensors, and Switches - - - - -	176
Figure 5-27	Stapler Cycles - - - - -	179
Figure 5-28	Recommended C-link Configuration (Daisy Chain)- - - - -	181
Figure 5-29	General Timing Diagram - - - - -	183
Figure 5-30	Copy Module System Block Diagram - - - - -	185
Figure 5-31	Copy Processor and key components - - - - -	187
Figure 5-32	Image path (1 of 2) - - - - -	196
Figure 5-33	Locations of ADF Sensors - - - - -	199
Figure 5-34	ADF Sensors functional diagram - - - - -	200
Figure 6-1	Phillips vs. Posidriv Screwdrivers - - - - -	203
Figure 6-2	Disk Drive - - - - -	205
Figure 6-3	Control Panel (1 of 2) - - - - -	215
Figure 6-4	Control Panel (2 of 2) - - - - -	216
Figure 6-5	AC Access Cover - - - - -	218
Figure 6-6	Back Cover - - - - -	219
Figure 6-7	Front Cover (1 of 2) - - - - -	220
Figure 6-8	Front Cover (2 of 2) - - - - -	221
Figure 6-9	Left Lower Cover - - - - -	222
Figure 6-10	Top Cover (1 of 2) - - - - -	223
Figure 6-11	Top Cover (2 of 2) - - - - -	224
Figure 6-12	Delivery Unit (1 of 2) - - - - -	226
Figure 6-13	Delivery Unit (2 of 2) - - - - -	227
Figure 6-14	Diverter Assembly - - - - -	229
Figure 6-15	Diverter Door Assembly - - - - -	230
Figure 6-16	Lower Right Door Assembly (1 of 3) - - - - -	231
Figure 6-17	Right Lower Door Assembly (2 of 3) - - - - -	232
Figure 6-18	Right Lower Door Assembly (3 of 3) - - - - -	233
Figure 6-19	Fan 1, Laser/Scanner (1 of 2) - - - - -	234
Figure 6-20	Fan 1, Laser/Scanner (2 of 2) - - - - -	235
Figure 6-21	Fan 2, Low Voltage Power Supply- - - - -	236
Figure 6-22	Fan 3, Formatter Fan - - - - -	237
Figure 6-23	Fan 4, Delivery Unit- - - - -	238
Figure 6-24	Fan 5 Removal (1 of 2) - - - - -	239

Figure 6-25	Fan 5 Removal (2 of 2) - - - - -	240
Figure 6-26	Tray 1 Removal (1 of 3) - - - - -	241
Figure 6-27	Tray 1 Removal (2 of 3) - - - - -	242
Figure 6-28	Tray 1 Removal (3 of 3) - - - - -	243
Figure 6-29	Tray 1 Pickup Unit Removal (1 of 4) - - - - -	244
Figure 6-30	Tray 1 Pickup Unit Removal (2 of 4) - - - - -	245
Figure 6-31	Tray 1 Pickup Unit Removal (3 of 4) - - - - -	246
Figure 6-32	Tray 1 Pickup Unit Removal (4 of 4) - - - - -	247
Figure 6-33	Feeder Assembly (1 of 2) - - - - -	248
Figure 6-34	Feeder Assembly (2 of 2) - - - - -	249
Figure 6-35	Formatter Assembly - - - - -	251
Figure 6-36	Fusing Assembly - - - - -	252
Figure 6-37	Laser/Scanner Assembly - - - - -	254
Figure 6-38	Main Gear Assembly (1 of 3) - - - - -	256
Figure 6-39	Main Gear Assembly (2 of 3) - - - - -	257
Figure 6-40	Main Gear Assembly (3 of 3) - - - - -	258
Figure 6-41	Main Motor - - - - -	259
Figure 6-42	Paper Input Unit - - - - -	260
Figure 6-43	DC Controller PCA - - - - -	261
Figure 6-44	Output Paper Sensor PCA (1 of 4) - - - - -	262
Figure 6-45	Output Paper Sensor PCA (2 of 4) - - - - -	263
Figure 6-46	Output Paper Sensor PCA (3 of 4) - - - - -	264
Figure 6-47	Output Paper Sensor PCA (4 of 4) - - - - -	265
Figure 6-48	Paper Size PCA (1 of 3) - - - - -	266
Figure 6-49	Paper Size PCA (2 of 3) - - - - -	267
Figure 6-50	Paper Size PCA (3 of 3) - - - - -	268
Figure 6-51	High Voltage Power Supply - - - - -	269
Figure 6-52	Low Voltage Power Supply - - - - -	270
Figure 6-53	Registration Assembly (1 of 3) - - - - -	271
Figure 6-54	Registration Assembly (2 of 3) - - - - -	272
Figure 6-55	Registration Assembly (3 of 3) - - - - -	273
Figure 6-56	Tray 1 Feed Roller - - - - -	274
Figure 6-57	Tray 1 Separation Pad - - - - -	275
Figure 6-58	Tray 2 and 3, Pickup, Feed, and Separation Rollers - - - - -	276
Figure 6-59	Paper Input Unit Sensor (PS2) - - - - -	278
Figure 6-60	Registration Sensor (PS1) - - - - -	280
Figure 6-61	Face-up Solenoid Assembly, SL3 - - - - -	281
Figure 6-62	Transfer Roller Assembly - - - - -	282
Figure 6-63	2000-sheet Input Tray Orientation - - - - -	286
Figure 6-64	2000-sheet Input Tray Front Cover - - - - -	287
Figure 6-65	2000-sheet Input Tray Back Cover - - - - -	288
Figure 6-66	2000-sheet Input Tray Left Cover - - - - -	289
Figure 6-67	2000-sheet Input Tray Right Cover - - - - -	290
Figure 6-68	2000-sheet Input Tray Main Drive Assembly - - - - -	291
Figure 6-69	2000-sheet Input Tray Paper Tray - - - - -	293
Figure 6-70	2000-sheet Input Tray Main Cable Harness - - - - -	295
Figure 6-71	2000-sheet Input Tray Controller PCA - - - - -	296

Figure 6-72	2000-sheet Input Tray Front LED PCA	- - - - -	299
Figure 6-73	2000-sheet Input Tray Pickup Assembly	- - - - -	300
Figure 6-74	2000-sheet Input Tray Power Supply	- - - - -	302
Figure 6-75	2000-sheet Input Tray Rollers: Pickup, Feed, and Separation	- - - - -	304
Figure 6-76	2000-sheet Input Tray Paper Size and Paper Quantity Switch	- - - - -	307
Figure 6-77	2000-sheet Input Tray Paper Size and Paper Quantity Switch Assemblies (2 of 2)	- - - - -	307
Figure 6-78	2000-sheet Input Tray Vertical Transfer Unit (VTU)	- - - - -	308
Figure 6-79	2000-sheet Input Tray Tension Springs	- - - - -	310
Figure 6-80	2000-sheet Input Tray Locating Pins	- - - - -	311
Figure 6-81	2000-sheet Input Tray Casters	- - - - -	312
Figure 6-82	2000-sheet Input Tray Adjustable Foot	- - - - -	313
Figure 6-83	Orientation of the 2 x 500-sheet Input Tray	- - - - -	315
Figure 6-84	Back Cover	- - - - -	316
Figure 6-85	Left Cover	- - - - -	317
Figure 6-86	Vertical Transfer Unit (VTU) (1 of 3)	- - - - -	318
Figure 6-87	Vertical Transfer Unit (VTU) (2 of 3)	- - - - -	319
Figure 6-88	Vertical Transfer Unit (VTU) (3 of 3)	- - - - -	320
Figure 6-89	Right Cover (1 of 3)	- - - - -	321
Figure 6-90	Right Cover (2 of 3)	- - - - -	322
Figure 6-91	Right Cover (3 of 3)	- - - - -	323
Figure 6-92	Front Top Cover (1 of 3)	- - - - -	324
Figure 6-93	Front Top Cover (2 of 3)	- - - - -	325
Figure 6-94	Front Top Cover (3 of 3)	- - - - -	326
Figure 6-95	Trays 4 and 5 (1 of 2)	- - - - -	327
Figure 6-96	Trays 4 and 5 (2 of 2)	- - - - -	328
Figure 6-97	Pickup Assembly (1 of 2)	- - - - -	329
Figure 6-98	Pickup Assembly (2 of 2)	- - - - -	330
Figure 6-99	Paper Deck Drive Assembly (1 of 2)	- - - - -	331
Figure 6-100	Paper Deck Drive Assembly (2 of 2)	- - - - -	332
Figure 6-101	Pickup, Feed, and Separation Rollers	- - - - -	333
Figure 6-102	2 x 500-sheet Input Tray Controller PCA	- - - - -	334
Figure 6-103	Tray-Size Sensing PCA (1 of 2)	- - - - -	335
Figure 6-104	Tray-Size Sensing PCA (2 of 2)	- - - - -	336
Figure 6-105	Power Supply	- - - - -	337
Figure 6-106	Main Cable (1 of 2)	- - - - -	338
Figure 6-107	Main Cable (2 of 2)	- - - - -	339
Figure 6-108	Storage Paper Tray	- - - - -	340
Figure 6-109	Front Door (Storage Area)	- - - - -	341
Figure 6-110	Castors	- - - - -	342
Figure 6-111	Foot Tip and Adjustable Foot Tip	- - - - -	343
Figure 6-112	Locating Pins	- - - - -	344
Figure 6-113	Front LED PCA	- - - - -	345
Figure 6-114	Orientation of the 7-bin Tabletop Mailbox	- - - - -	348
Figure 6-115	Front cover (1 of 3)	- - - - -	349
Figure 6-116	Front cover (2 of 3)	- - - - -	350
Figure 6-117	Front cover (3 of 3)	- - - - -	351

Figure 6-118	Back cover (1 of 2)	- - - - -	352
Figure 6-119	Back cover (2 of 2)	- - - - -	353
Figure 6-120	Top cover (1 of 4)	- - - - -	354
Figure 6-121	Top cover (2 of 4)	- - - - -	355
Figure 6-122	Top cover (3 of 4)	- - - - -	356
Figure 6-123	Top cover (4 of 4)	- - - - -	357
Figure 6-124	Mailbox Controller PCA	- - - - -	358
Figure 6-125	Mailbox Power Supply	- - - - -	359
Figure 6-126	Right Door Assembly (Paper Path Cover) (1 of 5)	- - - - -	360
Figure 6-127	Right Door Assembly (Paper Path Cover) (2 of 5)	- - - - -	361
Figure 6-128	Right Door Assembly (Paper Path Cover) (3 of 5)	- - - - -	361
Figure 6-129	Right Door Assembly (Paper Path Cover) (3 of 5)	- - - - -	362
Figure 6-130	Right Door Assembly (Paper Path Cover) (4 of 5)	- - - - -	363
Figure 6-131	Face-down Bins (1 of 3)	- - - - -	364
Figure 6-132	Face-down Bins (2 of 3)	- - - - -	365
Figure 6-133	Face-down Bins (3 of 3)	- - - - -	366
Figure 6-134	Empty Bin Sensor PCA (1 of 2)	- - - - -	367
Figure 6-135	Empty Bin Sensor PCA (2 of 2)	- - - - -	368
Figure 6-136	Full Bin and Interlock Sensor PCA (1 of 2)	- - - - -	369
Figure 6-137	Full Bin and Interlock Sensor PCA (2 of 2)	- - - - -	370
Figure 6-138	LED PCA	- - - - -	371
Figure 6-139	Face-up Sensors PCA	- - - - -	372
Figure 6-140	Reversing Mechanism Motor (1 of 2)	- - - - -	373
Figure 6-141	Reversing Mechanism Motor (2 of 2)	- - - - -	374
Figure 6-142	Face-up/Diverter Assembly (Flipper) (1 of 3)	- - - - -	375
Figure 6-143	Face-up/Diverter Assembly (Flipper) (2 of 3)	- - - - -	376
Figure 6-144	Face-up/Diverter Assembly (Flipper) (3 of 3)	- - - - -	377
Figure 6-145	Short Tray 7	- - - - -	378
Figure 6-146	Solenoid Reversing Mechanism	- - - - -	379
Figure 6-147	Flipper Solenoid	- - - - -	380
Figure 6-148	7-bin Tabletop Mailbox Handle	- - - - -	381
Figure 6-149	Latching Mechanism	- - - - -	382
Figure 6-150	Cover Latch	- - - - -	383
Figure 6-151	Orientation of the 8-bin Mailbox	- - - - -	385
Figure 6-152	8-bin Mailbox Covers (Front and Back)	- - - - -	386
Figure 6-153	8-bin Mailbox Top Cover	- - - - -	387
Figure 6-154	8-bin Mailbox Power Supply	- - - - -	388
Figure 6-155	8-bin Mailbox Paper Bins and Blind Cover	- - - - -	389
Figure 6-156	8-bin Mailbox Flipper Assembly (1 of 3)	- - - - -	390
Figure 6-157	8-bin Mailbox Flipper Assembly (2 of 3)	- - - - -	391
Figure 6-158	8-bin Mailbox Flipper Assembly (3 of 3)	- - - - -	392
Figure 6-159	8-bin Mailbox Delivery Head Motor	- - - - -	393
Figure 6-160	8-bin Mailbox Transport Belt Motor	- - - - -	394
Figure 6-161	8-bin Mailbox Input Paper Guide (1 of 2)	- - - - -	396
Figure 6-162	8-bin Mailbox Input Paper Guide (2 of 2)	- - - - -	397
Figure 6-163	8-bin Mailbox Metal Tape and Housing Assembly (1 of 2)	- - - - -	398
Figure 6-164	8-bin Mailbox Metal Tape and Housing Assembly (2 of 2)	- - - - -	399

Figure 6-165	8-bin Mailbox Controller PCA (1 of 2)	- - - - -	400
Figure 6-166	8-bin Mailbox Controller PCA (2 of 2)	- - - - -	401
Figure 6-167	8-bin Mailbox Anticurl Strings (1 of 2)	- - - - -	402
Figure 6-168	8-bin Mailbox Anticurl Strings (2 of 2)	- - - - -	403
Figure 6-169	8-bin Mailbox Delivery Head Assembly (1 of 4)	- - - - -	404
Figure 6-170	8-bin Mailbox Delivery Head Assembly (2 of 4)	- - - - -	405
Figure 6-171	8-bin Mailbox Delivery Head Assembly (3 of 4)	- - - - -	406
Figure 6-172	8-bin Mailbox Delivery Head Assembly (4 of 4)	- - - - -	407
Figure 6-173	8-bin Mailbox Interlock Switch	- - - - -	409
Figure 6-174	8-bin Mailbox Diagnostic LED PCA (1 of 2)	- - - - -	410
Figure 6-175	8-bin Mailbox Diagnostic LED PCA (2 of 2)	- - - - -	411
Figure 6-176	8-bin Mailbox User Status LED PCA (1 of 2)	- - - - -	412
Figure 6-177	8-bin Mailbox User Status LED PCA (2 of 2)	- - - - -	413
Figure 6-178	8-bin Mailbox Adjustable and Fixed Casters	- - - - -	414
Figure 6-179	8-bin Mailbox Attachment Assembly	- - - - -	415
Figure 6-180	Mailbox with Stapler, Stapler Removal or Installation	- - - - -	417
Figure 6-181	C-link Cable on Mailbox with Stapler	- - - - -	418
Figure 6-182	Back Plate (1 of 2)	- - - - -	419
Figure 6-183	Back Plate (2 of 2)	- - - - -	420
Figure 6-184	Stapler Controller PCA (1 of 3)	- - - - -	421
Figure 6-185	Stapler Controller PCA (2 of 3)	- - - - -	422
Figure 6-186	Stapler Controller PCA (3 of 3)	- - - - -	423
Figure 6-187	Top Cover Assembly	- - - - -	424
Figure 6-188	Stapler Bed Assembly	- - - - -	425
Figure 6-189	Hinges	- - - - -	427
Figure 6-190	Optional Output Accessory	- - - - -	433
Figure 6-191	Copy Connect EIO Board (slot 3)	- - - - -	434
Figure 6-192	View with HP Digital Copy 320 Stand (preferred configuration)	- - - - -	435
Figure 6-193	View with HP Digital Copy 320 on Tabletop	- - - - -	435
Figure 6-194	Orientation of the HP Digital Copy 320	- - - - -	439
Figure 6-195	Separation Pad Assembly	- - - - -	440
Figure 6-196	Pick Roller Cover	- - - - -	441
Figure 6-197	Pick Rollers (1 of 2)	- - - - -	442
Figure 6-198	Pick Rollers (2 of 2)	- - - - -	443
Figure 6-199	Document Holding Pad	- - - - -	445
Figure 6-200	Paper Chute Flip-out	- - - - -	446
Figure 6-201	Output Tray	- - - - -	447
Figure 6-202	FB Cover Assembly	- - - - -	448
Figure 6-203	Thumb Screw for Document Cover Assembly	- - - - -	449
Figure 6-204	Removing the Cover from the Posts	- - - - -	450
Figure 6-205	ADF Latch Cap	- - - - -	451
Figure 6-206	ADF Cover (1 of 2)	- - - - -	452
Figure 6-207	ADF Cover (2 of 2)	- - - - -	453
Figure 6-208	Front Panel (1 of 2)	- - - - -	454
Figure 6-209	Front Panel (2 of 2)	- - - - -	455
Figure 6-210	Front Panel Cable Clamp and Front Panel Frame Ground Plate	- - - - -	456
Figure 6-211	Front Panel Ribbon Cable	- - - - -	457

Figure 6-212	Unplugging the Ribbon Cable	- - - - -	458
Figure 6-213	Panel Cover (bottom view)	- - - - -	459
Figure 6-214	Front Panel Brackets (1 of 2)	- - - - -	460
Figure 6-215	Front Panel Brackets (2 of 2)	- - - - -	461
Figure 6-216	Upper Cover (1 of 2)	- - - - -	462
Figure 6-217	Upper Cover (2 of 2)	- - - - -	463
Figure 6-218	Copy Processor Board	- - - - -	464
Figure 6-219	Power Supply and Main Board Tray (1 of 2)	- - - - -	465
Figure 6-220	Power Supply and Main Board Tray (2 of 2)	- - - - -	466
Figure 6-221	RFI Cover (inside/rear view)	- - - - -	467
Figure 6-222	RFI Cover (outside/front view)	- - - - -	468
Figure 6-223	Control PCA	- - - - -	469
Figure 6-224	Card Cage	- - - - -	470
Figure 6-225	EEPROM	- - - - -	471
Figure 6-226	Fan	- - - - -	472
Figure 6-227	Power Supply	- - - - -	473
Figure 6-228	Back PCA	- - - - -	474
Figure 6-229	Optical Unit (1 of 2)	- - - - -	475
Figure 6-230	Optical Unit (2 of 2)	- - - - -	476
Figure 6-231	ADF Lamp PCA (1 of 2)	- - - - -	477
Figure 6-232	ADF Lamp PCA (2 of 2)	- - - - -	478
Figure 6-233	ADF Lamp	- - - - -	479
Figure 6-234	Sensor Unit Assembly (1 of 3)	- - - - -	480
Figure 6-235	Sensor Unit Assembly (2 of 3)	- - - - -	481
Figure 6-236	Sensor Unit Assembly (3 of 3)	- - - - -	482
Figure 6-237	ADF Motor Unit	- - - - -	483
Figure 6-238	ADF Belt	- - - - -	484
Figure 6-239	LED Assembly PCA	- - - - -	486
Figure 6-240	ADF Unit (shown without Optical Unit)	- - - - -	487
Figure 6-241	Front Panel Frame Ground Spring	- - - - -	488
Figure 6-242	Output Tray Brackets	- - - - -	489
Figure 6-243	Glass Plate Assembly	- - - - -	490
Figure 6-244	Idle Roller Coil Spring	- - - - -	491
Figure 6-245	Home Position Sensor (1 of 2)	- - - - -	492
Figure 6-246	Home Position Sensor (2 of 2)	- - - - -	493
Figure 6-247	Dust Cover	- - - - -	494
Figure 6-248	Lamp (1 of 2)	- - - - -	495
Figure 6-249	Lamp (2 of 2)	- - - - -	496
Figure 6-250	Carrier Unit (1 of 2)	- - - - -	497
Figure 6-251	Carrier Unit (2 of 2)	- - - - -	498
Figure 6-252	Carrier Belt	- - - - -	499
Figure 6-253	Unplugging the Ribbon Cable	- - - - -	500
Figure 6-254	Felt Pad	- - - - -	501
Figure 6-255	Feet	- - - - -	502
Figure 6-256	Frame Ground Spring	- - - - -	503
Figure 6-257	Front Lamp PCA	- - - - -	504
Figure 6-258	Junction PCA Cover	- - - - -	505

Figure 6-259	Junction PCA - - - - -	506
Figure 6-260	Front Panel Ribbon Cable- - - - -	507
Figure 6-261	Unplugging the Ribbon Cable - - - - -	508
Figure 6-262	Carrier Belt and Motor (1 of 2)- - - - -	509
Figure 6-263	Carrier Belt and Motor (2 of 2)- - - - -	510
Figure 7-1	Troubleshooting Process - - - - -	515
Figure 7-2	Mopier System Troubleshooting Process - - - - -	517
Figure 7-3	Mopier and Paper-Handling Troubleshooting Process (1 of 2) - - - - -	518
Figure 7-4	Mopier and Paper-Handling Troubleshooting Process (2 of 2) - - - - -	519
Figure 7-5	Copy Module Troubleshooting Process (1 of 2) - - - - -	520
Figure 7-6	Copy Module Troubleshooting Process (2 of 2) - - - - -	521
Figure 7-7	Communications Link (C-link) Cables, Supported Daisy Chain Connections - - - - -	523
Figure 7-8	Sample JetDirect Configuration Page - - - - -	526
Figure 7-9	Fan Location and Airflow - - - - -	536
Figure 7-10	Engine Test Button - - - - -	537
Figure 7-11	Sample Event Log - - - - -	539
Figure 7-12	Error Format for Paper Handling - - - - -	543
Figure 7-13	Paper Path Jam Locations - - - - -	583
Figure 7-14	Paper Path Test Source and Output Selection - - - - -	585
Figure 7-15	Sample Menu Map - - - - -	588
Figure 7-16	Sample Mopier Configuration Page (1 of 2) - - - - -	590
Figure 7-17	Sample Copy Module Configuration Page - - - - -	591
Figure 7-18	Sample File Directory Page - - - - -	592
Figure 7-19	Sample Usage Page - - - - -	594
Figure 7-20	Repetitive Defect Ruler - - - - -	613
Figure 7-21	High Voltage Power Supply Contacts - - - - -	616
Figure 7-22	8-bin Mailbox LEDs Description - - - - -	630
Figure 7-23	8-bin Mailbox Power Supply Test Mode Switch - - - - -	631
Figure 7-24	Printer Sensors and Switches - - - - -	639
Figure 7-25	Printer Motor, Clutches, and Solenoids - - - - -	640
Figure 7-26	DC Controller Inputs and Outputs (1 of 5) - - - - -	641
Figure 7-27	DC Controller Inputs and Outputs (2 of 5) - - - - -	642
Figure 7-28	DC Controller Inputs and Outputs (3 of 5) - - - - -	643
Figure 7-29	DC Controller Inputs and Outputs (4 of 5) - - - - -	644
Figure 7-30	DC Controller Inputs and Outputs (5 of 5) - - - - -	645
Figure 7-31	Mailbox with Stapler Wiring Diagram - - - - -	646
Figure 7-32	2000-sheet Input Tray Controller PCA Inputs - - - - -	647
Figure 7-33	2000-sheet Input Tray Controller PCA Outputs - - - - -	648
Figure 7-34	2000-sheet Input Tray Main Wiring Diagram - - - - -	649
Figure 7-35	8-bin Mailbox Main Wiring Diagram - - - - -	650
Figure 7-36	Copy Processor LEDs - - - - -	664
Figure 7-37	Locations of ADF Sensors - - - - -	667
Figure 8-1	HP Mopier 320 Paper-Handling Components - - - - -	676
Figure 8-2	Printer Covers and Doors - - - - -	680
Figure 8-3	Printer Internal Components (1 of 4)- - - - -	682
Figure 8-4	Printer Internal Components (2 of 4)- - - - -	684

Figure 8-5	Printer Internal Components (3 of 4)-	- - - - -	686
Figure 8-6	Printer Internal Components (4 of 4)-	- - - - -	688
Figure 8-7	Detail of Assemblies	- - - - -	690
Figure 8-8	PCB Assembly Location Diagram	- - - - -	692
Figure 8-9	Face-up Solenoid Assembly-	- - - - -	693
Figure 8-10	2000-sheet Input Tray Components (1 of 2)	- - - - -	694
Figure 8-11	2000-sheet Input Tray Components (2 of 2)	- - - - -	696
Figure 8-12	2 x 500-sheet Input Tray Internal Components-	- - - - -	698
Figure 8-13	7-bin Tabletop Mailbox Internal Components	- - - - -	702
Figure 8-14	8-bin Mailbox Components (1 of 3)	- - - - -	706
Figure 8-15	8-bin Mailbox Components (2 of 3)	- - - - -	708
Figure 8-16	8-bin Mailbox Components (3 of 3)	- - - - -	710
Figure 8-17	Stapler Internal Components	- - - - -	712
Figure 8-18	Assembly Location Diagram-	- - - - -	735
Figure 8-19	Covers	- - - - -	736
Figure 8-20	Flatbed	- - - - -	738
Figure 8-21	Glass Plate and PCA Assembly	- - - - -	740
Figure 8-22	Carrier Unit	- - - - -	742
Figure 8-23	ADF Unit	- - - - -	744
Figure 8-24	Optical Unit	- - - - -	746
Figure 8-25	Document Cover Assembly	- - - - -	747
Figure 8-26	Screws (1 of 4)	- - - - -	748
Figure 8-27	Screws (2 of 4)	- - - - -	748
Figure 8-28	Screws (3 of 4)	- - - - -	749
Figure 8-29	Screws (4 of 4)	- - - - -	749

List of Tables

Table 1-1.	Features of the Mopier Engine	2
Table 1-2.	Paper Capacities and Sizes	11
Table 1-4.	Accessories and Options	24
Table 1-5.	Minimum Memory Requirements	31
Table 1-6.	Declaration of Conformity (HP Mopier 320)	39
Table 1-7.	Declaration of Conformity (HP Digital Copy 320)	40
Table 2-1.	Mopier and Toner Cartridge Environmental Conditions	50
Table 2-2.	Dimensions of Mopier and Paper-handling Devices	51
Table 2-3.	Dimensions of Output Devices	52
Table 2-4.	Electrical Specifications	53
Table 2-5.	Acoustic Emissions	54
Table 2-6.	Specifications for Copy Module	55
Table 3-1.	Control Panel Keys	58
Table 3-2.	Indicator Lights	59
Table 3-3.	Factory Default Settings	63
Table 3-4.	Quick Copy Jobs Menu	66
Table 3-5.	Private/Stored Jobs Menu	66
Table 3-6.	Information Menu	67
Table 3-7.	Paper Handling Menu	68
Table 3-8.	Print Quality Menu	70
Table 3-9.	Printing Menu	72
Table 3-10.	Configuration Menu	75
Table 3-11.	I/O Menu	80
Table 3-12.	EIO Menu	82
Table 3-13.	Resets Menu	84
Table 3-14.	Service Mode Menu Items	85
Table 3-15.	Status Bar	91
Table 3-16.	Menu Tabs	92
Table 3-17.	Context-sensitive Help	97
Table 3-18.	Default Configurations	97
Table 3-19.	Functions of Buttons and LEDs	98
Table 3-20.	Start Button LED States	99
Table 3-21.	Default Settings	100
Table 4-1.	Cleaning the Printer	114
Table 4-2.	Cleaning the Document Cover, Document Holder, and Flatbed Glass	121
Table 4-3.	Cleaning the ADF	122
Table 5-1.	Printer Sensors, Solenoids, Clutches, Motors, and Fans	151
Table 5-2.	Paper Size Switches	153
Table 5-3.	2000-sheet Input Tray Sensors, Switches, Clutches and Motors	156
Table 5-4.	2000-sheet Input Tray Paper Quantity Switches	158

Table 5-5.	2000-sheet Input Tray Paper Size Switches - - - - -	158
Table 5-6.	2 x 500-sheet Input Tray Sensors, Switches, and Motors- - - -	161
Table 5-7.	2 x 500-sheet Input Tray Switches- - - - -	162
Table 5-8.	7-bin Tabletop Mailbox Sensors, Switches, and Motors - - - -	165
Table 5-9.	8-bin Mailbox Sensors, Switches, Motors, and Controller PCA - -	171
Table 5-10.	Stapler Motors, Sensors, and Switches - - - - -	177
Table 5-11.	Printer Timing- - - - -	182
Table 5-12.	Parallel Cable Pin Assignments - - - - -	184
Table 6-1.	Hardware Table- - - - -	212
Table 6-2.	Hardware Table- - - - -	437
Table 7-1.	Paper Curl - - - - -	533
Table 7-2.	Power On Defects or Blank Display - - - - -	534
Table 7-3.	Fans - - - - -	536
Table 7-4.	Engine Error Messages - - - - -	545
Table 7-5.	2000-sheet Input Tray Error Messages - - - - -	557
Table 7-6.	2 x 500-sheet Input Tray Error Messages - - - - -	561
Table 7-7.	Envelope Feeder Error Messages - - - - -	564
Table 7-8.	7-bin Tabletop Mailbox Error Messages - - - - -	565
Table 7-9.	8-bin Mailbox Error Messages- - - - -	570
Table 7-10.	Stapler Error Messages - - - - -	576
Table 7-11.	Duplexer Error Messages - - - - -	579
Table 7-12.	Paper Handling Controller Error Messages - - - - -	580
Table 7-13.	General Paper Path Troubleshooting Questions - - - - -	581
Table 7-14.	Key to Figure 7-15 - - - - -	588
Table 7-15.	Printer Devices Troubleshooting- - - - -	596
Table 7-16.	Image Quality- - - - -	597
Table 7-17.	Blank (White) Page - - - - -	599
Table 7-18.	Black Pages - - - - -	599
Table 7-19.	Fading Print - - - - -	600
Table 7-20.	Dropout- - - - -	602
Table 7-21.	Black Lines (parallel or perpendicular to path) - - - - -	602
Table 7-22.	Toner Smear - - - - -	603
Table 7-23.	Background Scatter - - - - -	604
Table 7-24.	Repetitive Defects - - - - -	605
Table 7-25.	Line at Edge of Paper- - - - -	606
Table 7-26.	Misshapen Characters, Voids - - - - -	607
Table 7-27.	Faulty Registration - - - - -	608
Table 7-28.	Image Skew - - - - -	608
Table 7-29.	Bubble Print - - - - -	609
Table 7-30.	White Stripes Parallel to Path - - - - -	610
Table 7-31.	Partial Blank Page - - - - -	610
Table 7-32.	Compressed Print- - - - -	611
Table 7-33.	Blank Portion in the Middle of the Page (Tray 4 Input only)- - -	611
Table 7-34.	DIP Switch Settings- - - - -	619
Table 7-35.	2000-sheet Input Tray LED Status Interpretation- - - - -	620
Table 7-36.	DIP Switch Settings for troubleshooting test procedures - - - -	622
Table 7-37.	Patterns of LED flashing (2-second pause between each pattern)	624

Table 7-38.	DIP switch settings for troubleshooting test	- - - - -	625
Table 7-39.	Patterns of Flashing LEDs	- - - - -	627
Table 7-40.	8-bin Mailbox LED Status Interpretation	- - - - -	633
Table 7-41.	Power On Checks	- - - - -	652
Table 7-42.	Display and Communication Checks	- - - - -	653
Table 7-43.	Boot Errors	- - - - -	655
Table 7-44.	Equipment Errors	- - - - -	656
Table 7-45.	Temporary Errors	- - - - -	658
Table 7-46.	Error Conditions	- - - - -	661
Table 7-47.	Copy Processor LED Test Results	- - - - -	665
Table 7-48.	Icon Conditions	- - - - -	666
Table 7-49.	Other Tests	- - - - -	669
Table 8-1.	Printer and Paper-Handling Components	- - - - -	677
Table 8-2.	Printer Covers and Doors	- - - - -	681
Table 8-3.	Printer Internal Components (1 of 4)	- - - - -	683
Table 8-4.	Printer Internal Components (2 of 4)	- - - - -	685
Table 8-5.	Printer internal Components (3 of 4)	- - - - -	687
Table 8-6.	Printer Internal Components (4 of 4)	- - - - -	689
Table 8-7.	Detail of Assemblies	- - - - -	691
Table 8-8.	PCB Assembly Locations	- - - - -	692
Table 8-9.	Face-up Solenoid Assembly	- - - - -	693
Table 8-10.	2000-sheet Input Tray Components (1 of 2)	- - - - -	695
Table 8-11.	2000-sheet Input Tray Components (2 of 2)	- - - - -	697
Table 8-12.	2 x 500-sheet Input Tray Internal Components	- - - - -	699
Table 8-13.	7-bin Tabletop Mailbox Internal Components	- - - - -	703
Table 8-14.	8-bin Mailbox Components (1 of 3)	- - - - -	707
Table 8-15.	8-bin Mailbox Components (2 of 3)	- - - - -	709
Table 8-16.	8-bin Mailbox Components (3 of 3)	- - - - -	711
Table 8-17.	Stapler Internal Components	- - - - -	713
Table 8-18.	Alphabetical Parts List	- - - - -	714
Table 8-19.	Numerical Parts List	- - - - -	724
Table 8-20.	Covers	- - - - -	737
Table 8-21.	Flatbed	- - - - -	738
Table 8-22.	Glass Plate and PCA Assembly	- - - - -	740
Table 8-23.	Carrier Unit	- - - - -	743
Table 8-24.	ADF Unit	- - - - -	744
Table 8-25.	Optical Unit	- - - - -	746
Table 8-26.	Document Cover Assembly	- - - - -	747
Table 8-27.	Screws (1 of 4)	- - - - -	748
Table 8-28.	Screws (2 of 4)	- - - - -	748
Table 8-29.	Screws (3 of 4)	- - - - -	749
Table 8-30.	Screws (4 of 4)	- - - - -	749
Table 8-31.	Alphabetical Parts List	- - - - -	750
Table 8-32.	Numerical Parts List	- - - - -	754

1

Product Information

Chapter Contents

Features of the HP Digital Copy 320	2
Product Overview	5
Paper Capacities and Sizes	11
Mopier Media Selection Guidelines	13
Copy Module Media Selection Guidelines	17
Identification	22
Paper-handling Devices, Accessories, and Options	23
Technical Assistance	32
Regulatory Information	34

Features of the HP Digital Copy 320

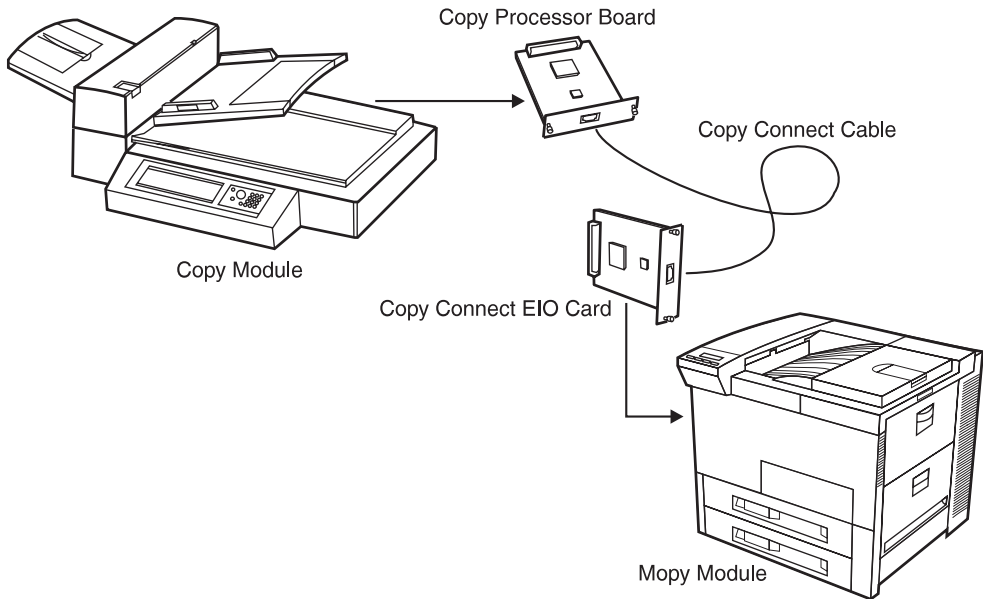

Figure 1-1 Copy System

Features of the Mopier

Table 1-1. Features of the Mopier Engine

Feature	Description
Print Speed	32 ppm letter or A4 17 ppm ledger (11 x 17) 18 ppm A3 20 ppm legal 20.5 ppm B4
Duplex Speed	12 ppm letter or A4 8.4 ppm ledger (11 x 17) or A3 9.0 ppm legal or B4

Table 1-1. Features of the Mopier Engine (continued)

Feature	Description
Text and Graphics Resolution	600 dpi with FastRes FastRes 1200 provides 1200 dpi quality at full speed plus Resolution Enhancement technology (REt)
Standard Printer Languages:	Enhanced PCL 6 PCL 5e for compatibility PostScript™ Level 2 emulation
Duty Cycle (Monthly Usage)	Up to 150,000 images
Internal Typefaces	45 PCL, 35 PostScript
Cartridge Slots	None
Power Control	PowerSave Mode
Control Panel	6 Keys, 3 LEDs, LCD Display (2-line, 16 characters per line)
EconoMode (draft quality)	Yes
Memory: ¹	48 MB ²
Standard Interfaces	IEEE 1284 ECP Parallel A to C connector JetDirect EIO
Duplexer	Standard
Hard Disk	Standard

1. Printer memory is optimized with Memory Enhancement technology (MEt). Printer has 16 MB RAM on board. DIMMs available for use include 4, 8, 16, and 64 MB modules. See Chapter 8 for option product numbers. SDRAM available includes 4, 8, 16, and 64 MB modules. EDO RAM available includes 4, 8, and 16 MB modules. 32 MB SD RAM modules are compatible, but not available from HP. A maximum of 192 MB RAM can be configured.
2. 16 MB on-board RAM, and one 32 MB DIMM.

Features of the Copy Module

- Straight-through paper path
- Automatic Document Feeder (ADF) - load original facedown
- One pass duplex scanning/2 complete optical systems
- 32 images per minute letter/A4 and 16 images per minute 11x17/A3
- Touch screen LED panel with keypad
- Copy module's 400 x 300 and 400 x 600 8-bit grayscale is converted to the Mopier's 600 x 600 dithered black and white (FastRes is sideband, 2-bit grayscale)
- Auto/Photo/Text modes
- IEEE 1394 high speed serial connection (Copy Processor Board to Copy Connect EIO)
- Job Interrupt (at copy boundaries)
- N-up layout (printing multiple pages per sheet)
- Auto-configure to Mopier settings
- Copy books
- Custom stapling
- Power Save
- Copy module firmware is stored on the Mopier's hard disk for easy upgrades
- Copy module can be placed on an optional copy stand (preferred configuration) or tabletop

Product Overview

External View of Mopier

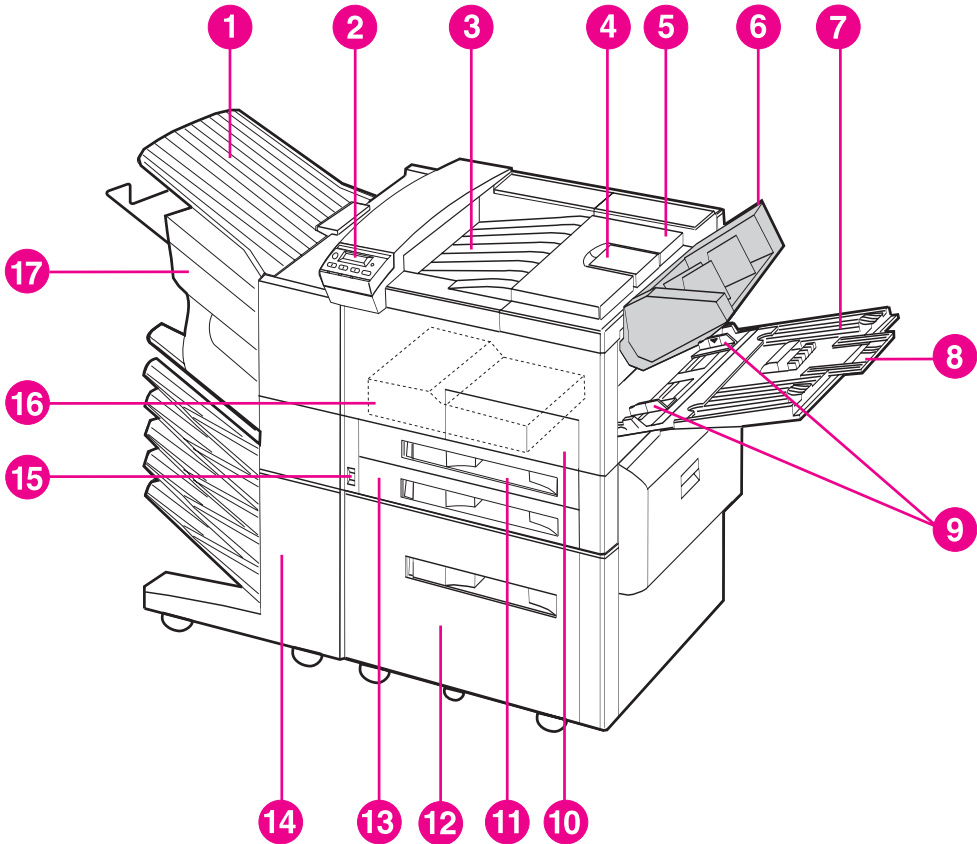

Figure 1-2 Mopier - Front and Right Side View with Tray 1 Open

- 1 Left Output Bin
- 2 Control Panel
- 3 Standard Output Bin
- 4 Adjustable Paper Stop
- 5 Top Cover
- 6 Envelope Feeder (optional)
- 7 Tray 1 (multipurpose)
- 8 Tray 1 Extensions

- 9** Tray 1 Paper Width Guides
- 10** Front Door
- 11** Tray 2
- 12** 2000-sheet Input Tray (Tray 4)
(not shown) 2 x 500-sheet Input Tray (Trays 4 & 5)
- 13** Tray 3
- 14** 5-bin Mailbox with Stapler
- 15** On/Off Switch
- 16** Duplexer (internal)
- 17** Stapler

Formatter Assemblies

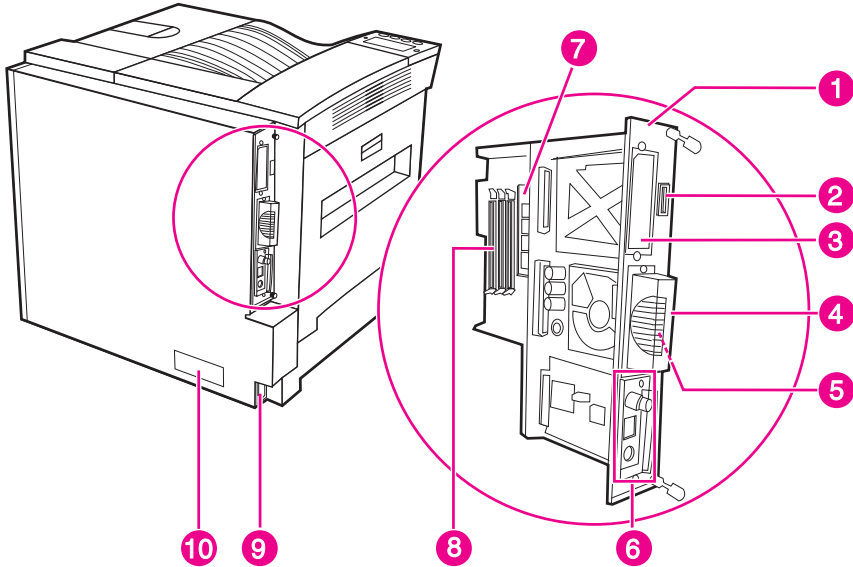

Figure 1-3 Rear and Left Side View

- 1 Formatter Pan Assembly
- 2 Parallel IEEE 1284 Interface Port
- 3 EIO Slot 3 Location
- 4 EIO Slot 2 Location [Hard Disk Location]
- 5 External Paper Handling Controller Port (behind EIO Slot 2/Hard Disk Accessory Location)
- 6 EIO Slot 1 Location
- 7 Firmware DIMM
- 8 DIMM Slots (3)
- 9 AC Power Connector
- 10 Model and Serial Number Label

External View of HP Digital Copy 320

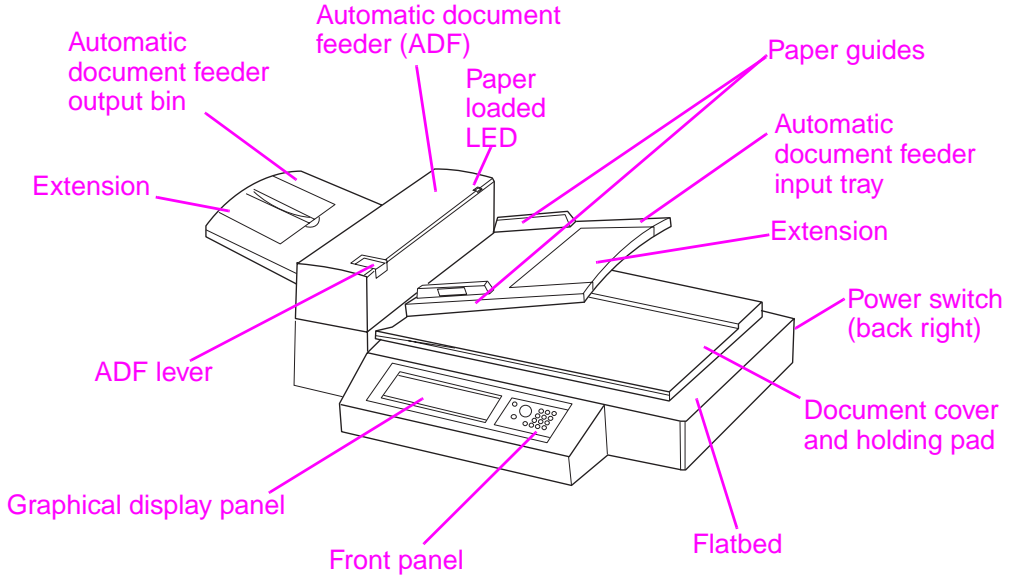

Figure 1-4 Front view of HP Digital Copy 320

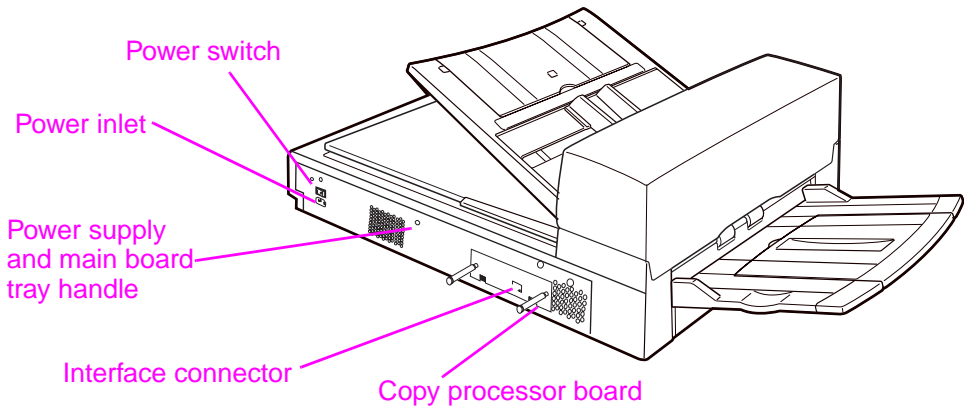

Figure 1-5 Rear view of HP Digital Copy 320

Configurations

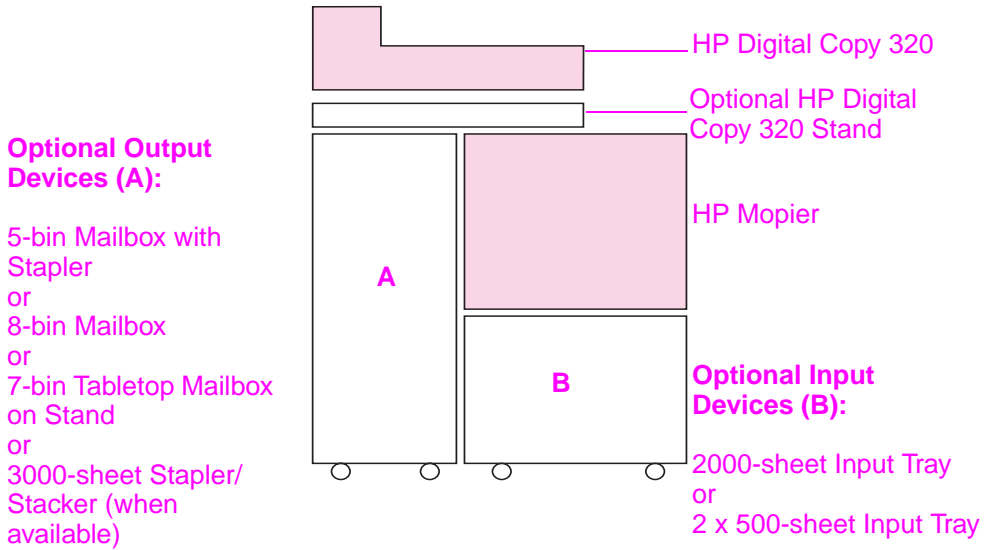

Figure 1-6 Preferred Configuration

Note

The HP Mopier 320 comes with the HP Digital Copy 320 in Europe. All other components are optional.

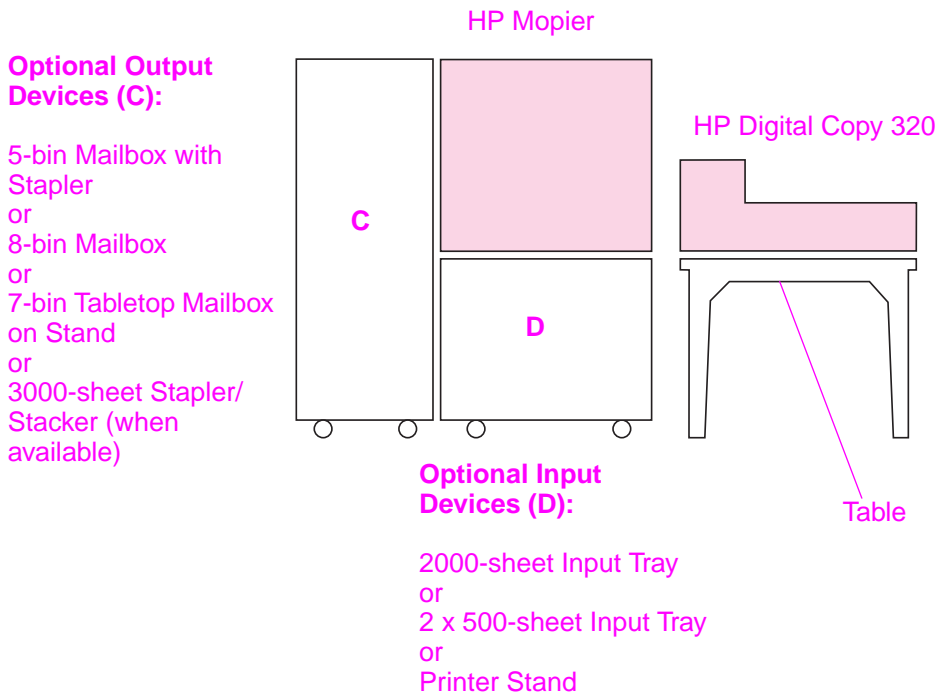

Figure 1-7 Tabletop Configuration

Note

The preferred configuration is the HP Digital Copy 320 and the HP Mopier on the HP Digital Copy 320 Stand with an optional A and B device.

The Printer Stand cannot be used with the HP Digital Copy 320 Stand.

Paper Capacities and Sizes

Mopier and Paper-handling Devices

Table 1-2. Paper Capacities and Sizes

Tray or Bin	Capacity	Paper	Weight
Tray 1 (multipurpose)	up to 100 sheets	<ul style="list-style-type: none"> ● Paper sizes: Letter, ISO A4, Executive, A5, Legal, 11 x 17, ISO A3, JIS B5, JIS B4, JPostD ● Custom sizes: Minimum: 3.67 x 7.5 in. (93 x 191 mm) Maximum: 11.7 x 17.7 in. (297 x 450 mm) <p>Note: Duplex printing is available for paper sizes from 5 x 7.5 in. to 11 x 17 in. (127 x 191 mm to 297 x 420 mm).</p> <ul style="list-style-type: none"> ● Other media types: transparencies, envelopes, and labels <p>Note: Envelopes, transparencies, and labels are supported only from Tray 1.</p>	16 to 53 lb Bond (60 to 199 g/m ²) Two-sided: 16 to 28 lb Bond (60 to 105 g/m ²)
Tray 2	up to 500 sheets	Paper sizes: Letter, ISO A4, Legal, JIS B4	16 to 28 lb (60 to 105 g/m ²)
Tray 3	up to 500 sheets	Paper sizes: Letter, ISO A4, Legal, JIS B4, ISO A3, 11 x 17	16 to 28 lb (60 to 105 g/m ²)
Face-down (Output bin)	up to 500 sheets	Paper sizes: Letter, ISO A4, A5, Executive, Legal, 11 x 17, ISO A3, JIS B5, JIS B4	
Face-up (Output bin)	up to 100 sheets	Paper sizes: Letter, ISO A4, A5, Executive, Legal, 11 x 17, ISO A3, JIS B5, JIS B4	
Optional 2000-sheet Input Tray (Tray 4)	up to 2,000 sheets	Paper sizes: Letter, ISO A4, Legal, JIS B4, ISO A3, 11 x 17	16 to 28 lb (60 to 105 g/m ²)
Optional Tray 4 (2 x 500-sheet Input Tray)	up to 500 sheets	Paper sizes: Letter, ISO A4, Legal, JIS B4	16 to 28 lb (60 to 105 g/m ²)

Table 1-2. Paper Capacities and Sizes (continued)

Tray or Bin	Capacity	Paper	Weight
Optional Tray 5 (2 x 500-sheet Input Tray)	up to 500 sheets	Paper sizes: Letter, ISO A4, Legal, JIS B4, ISO A3, 11 x 17	16 to 28 lb (60 to 105 g/m ²)
5-bin Mailbox with Stapler and 8-bin Mailbox	up to 250 sheets per bin	Paper sizes: Letter, ISO A4, Legal, JIS B4, ISO A3, 11 x 17, envelopes, transparencies, and labels Note: Envelopes, transparencies, and labels are only supported in the Face-up (left) output bin. The staple bin only supports A4 and Letter paper sizes.	16 to 28 lb (60 to 105 g/m ²)
7-bin Tabletop Mailbox	up to 120 sheets per bin	Paper sizes: Letter, ISO A4, Legal Note: B5, JIS B4, 11 x 17, ISO A3, envelopes, transparencies, and labels are only supported in the Face-up Bin.	16 to 28 lb (60 to 105 g/m ²)
Envelope Feeder	up to 100 envelopes	Envelope sizes: Commercial #28, C5, DL, Monarch, ISO B5, JPostD	16 to 24 lb (60 to 90 g/m ²)
Duplexer		Paper sizes: Letter, Legal, 11 x 17, A3, A4, B4	16 to 28 lb (60 to 105 g/m ²)

Mopier Media Selection Guidelines

Note

More detailed specifications are in the *HP Mopier 320 User Guide* and the *HP LaserJet Printer Family Paper Specification Guide*. See *Documentation* in “Accessories and Options” on page 24.

Paper

To achieve the best possible print quality and avoid paper jams, follow these guidelines for selecting paper:

- Use only copier grade paper that meets all specifications in the paper specification guide. Avoid paper with embossed lettering, perforations, or texture that is too smooth or too rough.
- Colored paper should be of the same high quality as white photocopy paper. The pigments must withstand the fusing temperature of 392° F (200° C) for 0.1 second without deterioration. Do not use paper with a colored coating that was added after the paper was produced.
- Pre-printed forms must be printed with non-flammable, heat-resistant inks that do not melt, vaporize, or release hazardous emissions when subjected to the fusing temperature of 392° F (200° C) for 0.1 second.
- A small sample of a new print media should be tested before purchasing large quantities.

Envelopes

CAUTION

To prevent severe damage to the printer, do not use envelopes that have windows, clasps, snaps, or any non-paper materials.

Print Envelopes to the Face-up Bin ONLY.

Envelopes can be printed from Tray 1 and from the optional Envelope Feeder. Choose envelopes that are well-constructed. They should lie flat and be sharply creased. They should not be wrinkled, nicked, or otherwise damaged. Envelope adhesive must be compatible with the heat and pressure of the fusing process.

Adhesive Labels

Use the following guidelines when selecting labels:

CAUTION

Tray 1 is required for printing adhesive labels.

Print labels to the Face-up Bin only.

This printer does not support use of labels with any exposed spaces.

Do not attempt to print on label sheets after any of the labels have been removed from the sheet. Damage to the printer may result.

- Labels must be arranged on the carrier sheet so that there are no exposed spaces on the sheet. Using label stock with spaces between rows or columns of labels can often result in labels peeling off during printing, causing serious jamming and possible damage to the printer.
- The top sheet (printing surface) must be of copier quality and provide good toner adhesion.
- The carrier sheet (backing sheet) must be compatible with the temperature and pressure of the fusing process, and must be coated for easy release of the top sheet.
- The adhesive must be stable at the 392° F (200° C) temperature encountered for 0.1 second in the fusing process, and must not produce emissions that exceed exposure levels or threshold limits established by OSHA and other safety agencies. Adhesives must not come into direct contact with any part of the printer.

A wide selection of suitable labels may be ordered through Hewlett-Packard. Available sizes are listed in the *HP LaserJet Printer Family Paper Specification Guide*.

Transparencies

CAUTION

Tray 1 is required for printing transparencies.

Print transparencies to the Face-up Bin only.

Transparencies used in HP LaserJet printers must be able to withstand the 392° F (200° C) temperature encountered in the printer's fusing process for 0.1 second. Suitable transparency film is available through Hewlett-Packard. See the *HP LaserJet Printer Family Paper Specification Guide* for details.

Storing Print Media

Follow these guidelines when stacking and storing print media:

- Store paper in its wrapper until ready to use.
- Re-wrap partially used packages of media before storing.
- Stack each carton upright and squarely on top of the other.
- Store envelopes in a protective box to avoid damaging the edges of the envelopes.
- Keep stored media away from temperature and humidity extremes.
- DO NOT store cartons or reams directly on the floor where they will absorb a higher moisture content. Instead, place cartons on a pallet or on shelves.
- DO NOT store individual reams in a manner that causes them to curl or warp along the edges.
- DO NOT stack more than six cartons on top of each other.
- DO NOT place anything on top of media, regardless of whether the paper is packaged or unpackaged.
- DO NOT store printed documents in vinyl folders (which may contain plasticizers) or expose the documents to petroleum-based solvents.

Shipping Print Media

When shipping print media through different environments, plastic wrap all cartons on the shipping pallet. When shipping media across bodies of water, wrap individual cartons as well. Packaging must protect the media from physical damage.

Paper Weight Equivalence Table

Use this table to determine approximate equivalent points in weight specifications other than U.S. bond weight. For example, to determine the equivalent of 20 lb U.S. bond weight paper in U.S. cover weight, locate the bond weight (in row 3, second column) and scan across the row to the cover weight (in the fourth column). The equivalent is 28 lb.

Shaded areas indicate a standard weight for that grade.

Table 1-3. Paper Weight Equivalence

	U.S. Post Card ¹ thickness (mm)	U.S. Bond Weight (lb)	U.S. Text/Book Weight (lb)	U.S. Cover Weight (lb)	U.S. Bristol Weight (lb)	U.S. Index Weight (lb)	U.S. Tag Weight (lb)	Europe Metric Weight (g/m ²)	Japan Metric Weight (g/m ²)
1		16	41	22	27	33	37	60	60
2		17	43	24	29	35	39	64	64
3		20	50	28	34	42	46	75	75
4		21	54	30	36	44	49	80	80
5		22	56	31	38	46	51	81	81
6		24	60	33	41	50	55	90	90
7		27	68	37	45	55	61	100	100
8		28	70	39	49	58	65	105	105
9		32	80	44	55	67	74	120	120
10		34	86	47	58	71	79	128	128
11		36	90	50	62	75	83	135	135
12	.18	39	100	55	67	82	91	148	148
13	.19	42	107	58	72	87	97	157	157
14	.20	43	110	60	74	90	100	163	163
15	.23	47	119	65	80	97	108	176	176
16		53	134	74	90	110	122	199	199

1. U.S. Post Card measurements are approximate. Use for reference only.

Copy Module Media Selection Guidelines

Paper Specifications

This section explains specifications of paper that can be used for the ADF unit. Any type of paper can be used on the flatbed.

Paper Size

Figure 1-8 shows the acceptable paper sizes.

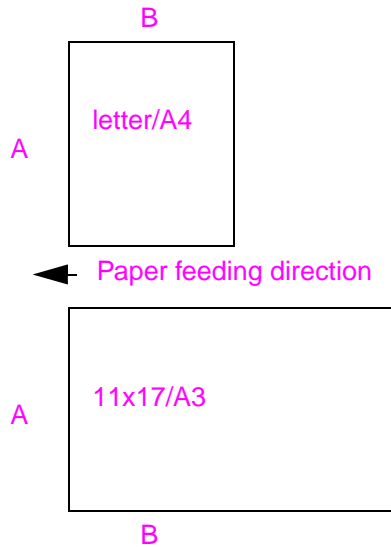

Figure 1-8 Paper size specification

Maximum		Minimum	
A	B	A	B
12 in. (297 mm)	17 in. (432 mm)	8 in. (210 mm)	6 in. (148 mm)
		6 in. (148)	8 in. (210 mm)

HP Digital Copy 320 Supported Sizes

- **Ledger** - 11 x 17 in. (279 x 432 mm)
- **Executive** - 7.3 x 10.5 in. (191 x 267 mm)
- **Letter** - 8.5 x 11 in. (216 x 279 mm)
- **Legal** - 8.5 x 14 in. (216 x 356 mm)
- **A3** - 11.7 x 16.5 in. (297 x 419 mm)
- **A4** - 8.3 x 11.7 in. (210 x 297 mm)
- **A5** - 5.8 x 8.2 in. (148 x 210 mm)
- **B4 (JIS)** - 10.1 x 14.3 in. (257 x 364 mm)
- **B5 (JIS)** - 7 x 9.9 in. (176 x 250 mm)

Paper Conditions

Ream Weight

Plain paper: 16 to 34 lb (52 to 127 g/m²)

Recycled paper: 17 to 24 lb (64 to 90 g/m²)

Bond paper: 16 to 28 lb (64 to 104 g/m²)

Note

The ADF holds up to 50 sheets of 24 lb. paper. Capacity will be less for thicker paper. For example, 24 lb HP LaserJet Paper has a capacity of 43, and 28 lb Xerox 4024 paper has a capacity of 32.

Document Quality

Do Not Load the following into the ADF:

- Carbonless paper or forms
- Paper with clips or staples
- Paper with wet ink or correction fluid
- Labels

Precautions

The following documents might be hard to feed through the ADF. If the document slips in the ADF (Jam Error) or a double-feed occurs often, use the HP Digital Copy 320's flatbed.

- Paper of unequal thickness, such as envelopes
- Paper with folds, tears, large wrinkles, or curl
- Paper with clips or staples
- Paper with wet ink
- Mixed paper sizes
- Color copied paper
- Tracing paper
- Coated paper
- Carbon paper
- Paper smaller than 6 x 4 in. (148 x 105 mm) or larger than A3 or 11 x 17 in.
- Other than paper
 - cloth
 - metal foil
 - transparency film
- Photographic paper
- Paper with notches on the side
- Paper that is not rectangular
- Thin paper

CAUTION

Use the flatbed for delicate paper or paper that does not meet specifications for the ADF.

Carbonless papers have the chemical composition which damages the Separation Pad and Pick Roller. Therefore, note the following remarks.

- Cleaning: If mispicks occur frequently, clean the Separation Pad and Pick Roller more often. See "Cleaning the ADF" on page 122.
- Replacement of parts: The Separation Pad and the Pick Roller should be replaced more often. See page 126.

Note

Paper should be stacked in the chute as shown in figure 1-9.

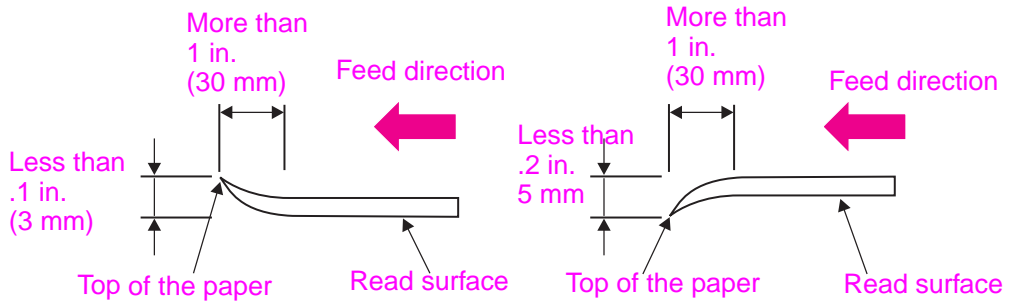

Figure 1-9 Paper orientation

Perforated Paper

Perforations in the areas shown in figure 1-10 may cause problems when the paper is fed through the ADF. If so, use the flatbed to read perforated paper.

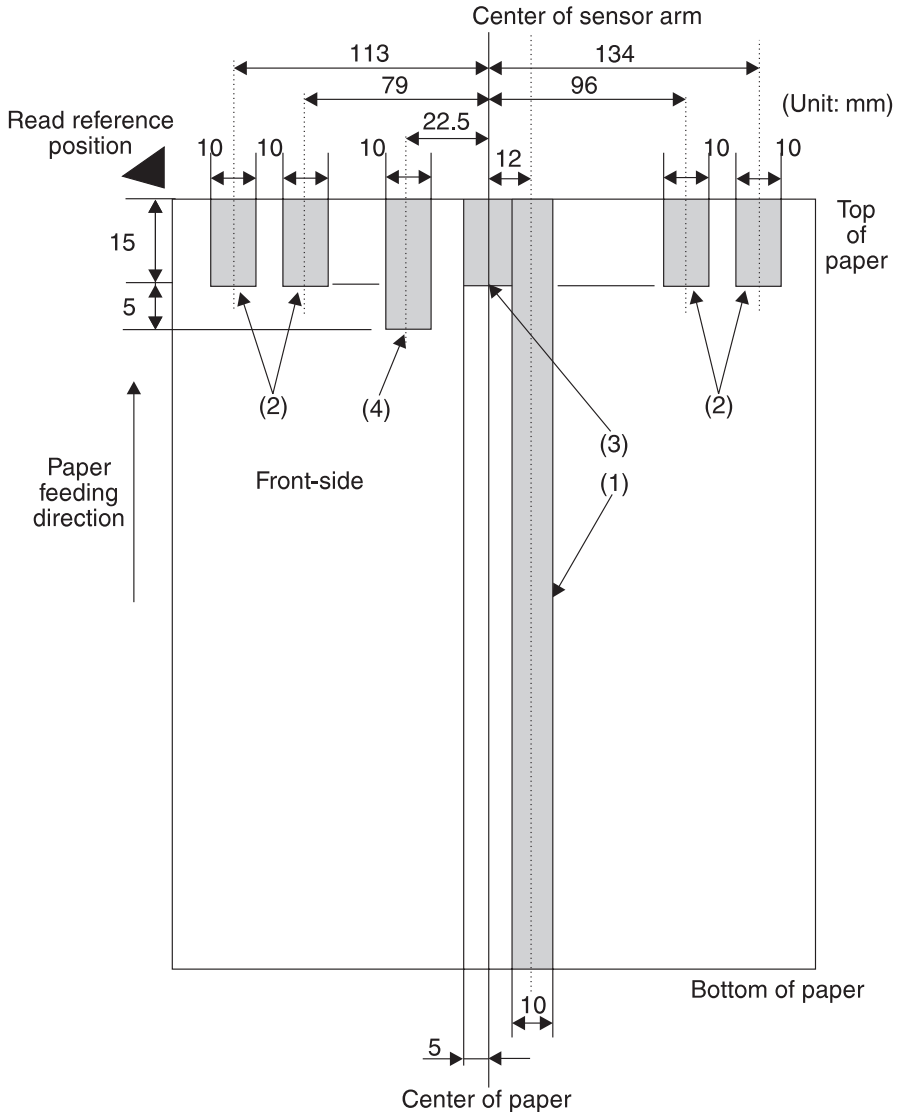

Figure 1-10 Areas of the Paper that Should Not Be Perforated

Identification

Model and Serial Numbers

The model and serial numbers are listed on identification labels located on the rear of the Mopier. The model number is alphanumeric, such as C4229A.

The serial number contains information about the Country of Origin, the Revision Level, the Production Code, and production number of the Mopier.

The label also contains power rating and regulatory information as shown in figure 1-11.

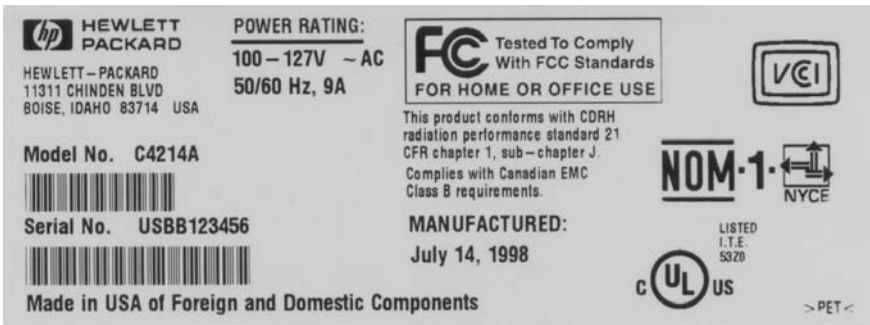

Figure 1-11 Sample Model and Serial Number Label for the Mopier

Note

The locations of the labels may change.

The identification labels for the copy module are located on the back cover, below the ADF.

The identification labels for the 2000-sheet Input Tray and 2 x 500-sheet Input Tray are located on the back panel, directly below the identification labels on the Mopier.

To locate the identification labels for the 8-bin Mailbox and 5-bin Mailbox with Stapler, detach the paper-handling device from the Mopier. The identification labels are located on the bottom right of the front side (side that attaches to Mopier).

To locate the identification labels for the 7-bin Tabletop Mailbox, detach the paper-handling device from the Mopier. The identification label is located on the bottom side of the back cover.

Paper-handling Devices, Accessories, and Options

The accessories and optional equipment for the Mopier are shown in figure 1-12 and described in table 1-4. The duplexer is standard. All the paper-handling devices in figure 1-12 and in table 1-4 are optional.

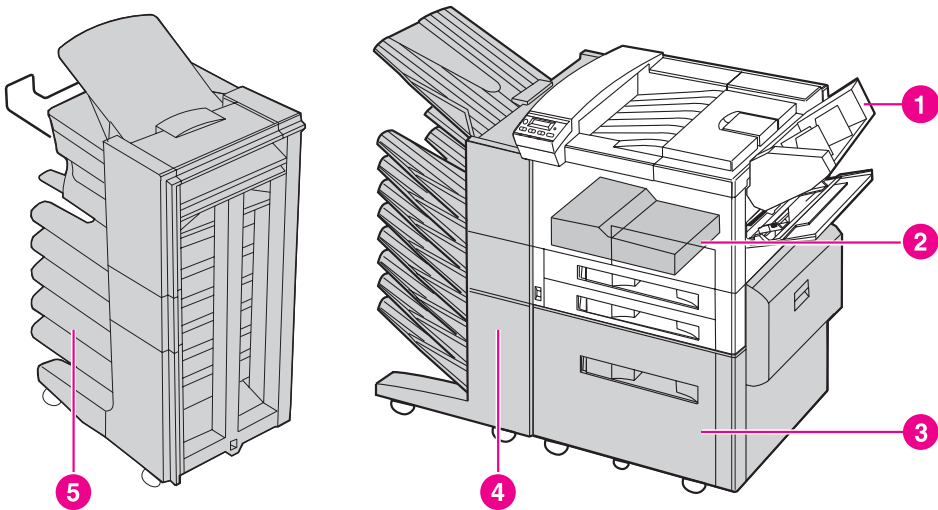

Figure 1-12 Paper Handling Devices

- 1 Envelope Feeder
- 2 Duplexer (standard, internal)
- 3 2000-sheet Input Tray (Tray 4)
(Not shown) 2 x 500-sheet Input Tray (Trays 4 and 5)
- 4 8-bin Mailbox (provides mailbox, job separation, collating, and job stacking)
- 5 5-bin Mailbox with Stapler (provides mailbox, job separation, job stacking, collating and stapling)

Not shown:

- 7-bin Tabletop Mailbox Stand
- 7-bin Tabletop Mailbox

Ordering Information

Use only accessories specifically designed for this printer. To order an accessory, contact an HP-authorized service or support provider.

Table 1-4. Accessories and Options

	Item	Description or Use	Order Number
Paper Handling	2 x 500-sheet Input Tray	Two 500-sheet Input Trays.	C4236A
	2000-sheet Input Tray	2000-sheet Input Tray.	C4237A
	Envelope Feeder	Automatically feeds up to 100 envelopes.	C4242A
	Duplex Printing Accessory (duplexer - standard on DN model)	Allows automatic printing on both sides of paper.	C4782A
	7-bin Tabletop Mailbox	Each of the 7 Face-down output bins holds 120 sheets of paper. One Face-up Bin holds 100 sheets of paper. Designed for tabletop use.	C4238A
	8-bin Mailbox	Each of the 8 output bins holds 250 sheets of paper.	C4240B
	5-bin Mailbox with Stapler	Each of the 5 output bins holds 250 sheets of paper. Provides job separation by stapling jobs.	C4241A

Table 1-4. Accessories and Options (continued)

Item	Description or Use	Order Number	
Printer Stands	Printer Stand	Used in place of the 2000-sheet Input Tray or the 2 x 500-sheet Input Tray when an 8-bin Mailbox or a 5-bin Mailbox with Stapler is attached.	C2975A
	Stand for 7-bin Tabletop Mailbox	Allows 7-bin Tabletop Mailbox to be used when printer is mounted on 2 x 500-sheet Input Tray, 2000-sheet Input Tray, or printer stand.	C4239A

Table 1-4. Accessories and Options (continued)

	Item	Description or Use	Order Number
Printing Supplies	HP Multipurpose Paper (Other HP media is available where office products are sold.)	HP brand paper for a variety of uses (1 box of 10 reams, 500 sheets each). To order a sample, in the U.S. call 1-800-471-4701.	HPM1120
	HP LaserJet Paper (Other HP media is available where office products are sold.)	Premium HP brand paper for use with HP LaserJet printers (1 box of 10 reams, 500 sheets each). To order a sample, in the U.S. call 1-800-471-4701.	HPJ1124
	Toner Cartridge (20,000 images)	Replacement HP Microfine toner cartridge.	C4182X

Table 1-4. Accessories and Options (continued)

Item	Description or Use	Order Number		
Memory, Fonts, and Mass Storage	Dual In-line Memory Module (DIMM) (100-pin)	Boosts the ability of the printer to handle large print jobs (maximum 192 MB with HP brand DIMMs).		
	EDO DIMMs (100-pin)	4 MB 8 MB 16 MB	C4135A C4136A C4137A	
	SDRAM DIMMs (100-pin)	4 MB 8 MB 16 MB 32 MB 64 MB	C4140A C4141A C4142A C4143A C3913A	
	Flash DIMM (100-pin)	Permanent storage for fonts and forms:		
		2 MB 4 MB	C4286A C4287A	
	Font DIMM (100-pin)	8 MB Asian ROM: traditional Chinese simplified Chinese	C4292A C4293A	
	Hard Disk	Permanent storage for fonts and forms (1.4 MB maximum storage for fonts). Enables Raster Image Processor (RIP) ONCE mopying of print jobs that are too large to RIP ONCE mopy in RAM.	C2985A	
	Cable and Interface Accessories	Parallel Cables	3 Meter IEEE-1284 cable 10 Meter IEEE-1284 cable	C2946A C2947A
		Macintosh Network Cable Kit	For PhoneNET or LocalTalk connection.	92215N

Table 1-4. Accessories and Options (continued)

	Item	Description or Use	Order Number
Cable and Interface Accessories	Enhanced I/O Cards	HP JetDirect print server multi-protocol EIO network cards: Ethernet (RJ-45 only) Ethernet (RJ-45 and BNC) and LocalTalk Token Ring (RJ-45 and DB-9) Fast Ethernet 10/100Base-TX (RJ-45 only)	J3110A J3111A J3112A J3113A
	Power Box	For connecting an 8-bin mailbox to the printer when the printer is on a printer stand. This item is included with the 2000-sheet Input Tray and the 2 x 500-sheet Input Tray.	C4789A
Maintenance Accessory	Preventive Maintenance Kit	For 110V units	C3914A
		For 220V units	C3914-69001 C3915A C3915-69001
Documentation	<i>HP LaserJet Printer Family Paper Specification Guide</i>	A guide to using paper and other print media with HP LaserJet printers.	5040-9092
	<i>HP JetDirect Print Server Software Installation Guide</i>	A guide to installing and using the JetDirect Print Server software with HP LaserJet printers. Contains information for multiple operating systems.	5967-2244 (English)
	<i>PCL 5/PJL Technical Reference Documentation Package</i>	A guide to using printer commands with HP LaserJet printers.	5021-0377
	<i>HP Mopier 320 User Guide</i>	This is an online user guide provided on compact disc.	C4229-60101

Table 1-4. Accessories and Options (continued)

Item	Description or Use	Order Number
Documentation <i>HP Mopier 320 Getting Started Guide</i>	An additional copy of the getting started guide.	C4229-90901
<i>HP Digital Copy 320 Getting Started Guide</i>	An additional copy of the copy module getting started guide.	C4230-90901
User Documentation Bundle	An additional copy of the getting started guide and the ready reference guide.	C4214-99001 (English)
<i>HP Mopier 320 Service Manual</i>	Service Manual.	C4229-90911

Hard Disk

The Mopier comes with a hard disk to permanently store downloaded fonts and forms in the printer. Unlike the standard printer memory, permanently downloaded items remain on the hard disk even when the printer is powered off.

Fonts downloaded to the hard disk are available to all users of the printer.

HP LaserJet Resource Manager

The HP LaserJet Resource Manager allows you to control hard disk and flash memory features not found in the drivers. Use the HP LaserJet Resource Manager to initialize disk and flash memory and to download, delete and manage fonts to disk, across networks. It is also used to update firmware for the HP Digital Copy 320. HP LaserJet Resource Manager is not available for the Macintosh.

Macintosh users can use the HP LaserJet Utility, and Windows® users can use the HP printer driver to download fonts. The printer hard disk can also be write-protected through software for additional security. See the online help associated with your HP software for more information.

For the Macintosh environment, see the online help in the HP LaserJet Utility Guide included with the HP LaserJet Utility software. For the Windows environment, see your HP Windows driver online help.

Determining Memory Requirements

The amount of memory you need depends on the types of documents you print. With the PCL printer language, the printer can print most text and graphics at 300 or 600 dpi without additional memory.

Add memory to your printer if you

- Commonly print complex graphics.
- Use many downloaded fonts.
- Print complex documents.
- Use advanced functions (such as I/O Buffering and Resource Saving).

You can remove the 32 MB DIMM and add up to 3 64 MB DIMMs for a total of 192 MB of usable memory.

Table 1-5 presents the amount of memory required for the most common print jobs performed with the HP Mopier using 600-dpi printing.

Table 1-5. Minimum Memory Requirements

Print Job	Paper Size	PCL Minimum Memory Requirements	PostScript Emulation Minimum Memory Requirements
single-sided printing	Letter, A4, Legal	16 MB	16 MB
	11 x 17 in, A3	16 MB	16 MB
two-sided printing	Letter, A4	16 MB	16 MB
	Legal	16 MB	16 MB
	11 x 17 in, A3	24 MB	24 MB

Technical Assistance

HP ASAP (Automated Support Access Program) provides free technical support information 24 hours a day, 7 days a week. The ASAP system includes HP FIRST, explained below. The ASAP service requires a touchtone phone.

HP FIRST (Fax Information Retrieval Support Technology)

HP FIRST (Fax Information Retrieval Support Technology) is a phone-in fax service providing technical information for HP LaserJet users as well as service personnel. Receiving a fax requires a type 3 facsimile machine or fax card. Service related information includes:

- Service notes (HP Authorized dealers)
- Application notes
- Product Data Sheets
- Material Safety Data Sheets (MSDS)
- Typeface and accessory information
- Printer support software information
- Toner information
- Driver request form and Software Matrix.

HP FIRST, U.S.

Call the HP ASAP system (1-800-333-1917) and follow the voice prompts to enter HP FIRST.

HP FIRST, Europe

Call HP FIRST at one of the following numbers:

- U.K., 0800-96-02-71
- Netherlands, 06-02-22-420
- Belgium (Dutch), 078-11-19-0
- Germany, 0130-810061
- Switzerland (German), 155-1527
- Austria, 0660-8128

For English service outside the above countries, (31) 20-681-5792.

Internet

Anonymous FTP library service is available for around-the-clock access to drivers, software, and technical support information for HP peripheral and computer products. Please note that paths may change without notice. Access the Internet or FTP address and use the menus to locate the software or support of your choice.

URL for Access HP: <http://www.hp.com>

URL for Software and Support: <http://www.hp.com/go/cposupport>

FTP address: <ftp.hp.com>

Login: anonymous

Password: your Internet name (or user identification)

FTP Path for Drive Software: `/pub/printers`

FTP Path for Network Software: `/pub/networking`

World Wide Web

Download printer driver software using www.hp.com/cposupport/eschome.html.

HP Reseller Sales and Service Support Line (US Only)

The Hardware Technical Support Center (HTSC) is available for technical support to assist Hewlett-Packard authorized service technicians. The HTSC can be reached at 1-800-544-9976 between 7:00 A.M. and 6:00 P.M. Mountain Standard Time, Monday, Tuesday, Thursday, and Friday. On Wednesdays the office closes at 4:00 P.M.

Other Areas

Outside of North America and Europe, contact your local HP sales office for assistance in obtaining technical support.

Regulatory Information

FCC Regulations

The HP Digital Copy 320 has been tested and found to comply with the limits for a Class A digital device pursuant to Part 15 of the FCC rules.

The Mopier 320 has been tested and found to comply with the limits for a Class B digital device, pursuant to Part 15 of the FCC rules. These limits are designed to provide reasonable protection against harmful interference in a residential installation. This equipment generates, uses, and can radiate radio frequency energy. If this equipment is not installed and used in accordance with the instructions, it may cause harmful interference to radio communications. However, there is no guarantee that interference will not occur in a particular installation. If this equipment does cause harmful interference to radio or television reception, which can be determined by turning the equipment off and on, the user is encouraged to try to correct the interference by one or more of the following measures:

- Reorient or relocate the receiving antenna.
- Increase separation between equipment and receiver.
- Connect equipment to an outlet on a circuit different from that to which the receiver is located.
- Consult your dealer or an experienced radio/TV technician.

Note

Any changes or modifications to the printer that are not expressly approved by HP could void the user's authority to operate this equipment.

Use of a shielded interface cable is required to comply with the Class B limits of Part 15 of FCC rules.

Environmental Product Stewardship

Protecting the Environment

Hewlett-Packard Company is committed to providing quality products in an environmentally-sound manner. The Mopier has been designed to minimize impacts on the environment.

The Mopier design eliminates:

Ozone Production

The Mopier uses charging rollers in the electrophotographic process and therefore generates no appreciable ozone gas (O₃).

CFC Usage

Class I U.S. Clean Air Act stratospheric ozone-depleting chemicals (chlorofluorocarbons [CFCs], for example) have been eliminated from the manufacturing of the Mopier and packaging.

The Mopier design reduces:

Energy Consumption

Energy usage drops from 500/505 (110V/220V units) watts (W) during printing to as little as 35/40 (110V/220V units) W while in low-power (Power Save) mode. This saves energy without affecting the high performance of the Mopier. This product qualifies for the ENERGY STAR Program (U.S. and Japan). ENERGY STAR is a voluntary program established to encourage the development of energy-efficient office products. The ENERGY STAR name is a registered service mark of the U.S. Environmental Protection Agency.

As an ENERGY STAR partner, Hewlett-Packard Company has determined that this product meets ENERGY STAR Guidelines for energy efficiency.



Toner Consumption

EconoMode uses about 50% less toner.

Paper use

The Mopier's optional duplexing feature, which provides for two-sided printing, reduces paper usage and the resulting demands on natural resources.

The design of the Mopier facilitates the recycling of:

Plastics

Plastic parts have material identification markings, according to international standards, which enhance the ability to identify plastics for proper disposition at the end of the Mopier's life.

HP Toner Cartridges

In many countries, this product's toner cartridge/drum can be returned to HP using the prepaid shipping label and instructions included inside each new HP Toner Cartridge box. If your country is not listed in the recycling guide, call your local HP Sales and Service Office for further instructions.

HP Cartridge Recycling Program information:

Since 1990, the HP LaserJet Toner Cartridge Recycling Program has collected more than twelve million cartridges that otherwise may have been discarded into landfills. Once a cartridge is returned, it is disassembled and reusable components are cleaned and inspected for quality conformance. After passing strict inspection procedures, materials such as nuts, screws, and clips are reclaimed and used to produce new cartridges. Remaining materials are melted down and used as raw materials for a variety of other products. Over 95 percent (%) of the weight of returned materials is recycled. For more information in the U.S., call (1) (800) 340-2445 or contact the HP LaserJet Supplies Website at <http://ljsupplies.com/planetpartners>. Non-US customers can call the local HP Sales and Service Office for further information regarding the HP Toner Cartridge Recycling Program.

Paper

The Mopier is suited for the use of recycled papers when the paper meets the guidelines outlined in the *HP LaserJet Printer Family Paper Specifications Guide*.

To ensure Mopier longevity, HP provides the following:

Spare Parts and Consumables Availability

Spare parts and consumable supplies for this product will be made available for at least five years after production has stopped.

Material Safety Data Sheet

The Toner Cartridge/Drum MSDS can be obtained by calling the U.S. HP FIRST (Fax Information Retrieval Support Technology) at (1) (800) 231-9300. Use Index number 7 for a listing of the Toner Cartridge/Drum Material/Chemical Safety Data Sheets. Non-U.S. customers should refer to the HP Support pages at the front of this user guide for appropriate phone numbers and information. For more information in the U.S., call (1) (800) 340-2445 or contact the HP LaserJet Supplies Website at <http://ljsupplies.com/planetpartners>.

Environmental Conformity

Plastics

Plastic parts have material identification markings, according to international standards, which enhance the ability to identify plastics for proper disposition at the end of the Mopier's life. The plastics used in the Mopier housing and chassis are technically recyclable.

Mopier and Parts

Design for recycling has been incorporated into the Mopier and its accessories. The number of materials has been kept to a minimum while ensuring proper functionality and high product reliability. Dissimilar materials have been designed to separate easily. Fasteners and other connections are easy to locate, access, and remove with common tools. High priority parts have been designed to be accessed quickly for efficient disassembly and repair. Plastic parts have been primarily designed in two colors to enhance recycling options. A few small parts are colored specifically to highlight customer access points.

HP disposes of returned products in an environmentally sound manner. Many of the functional parts are recovered, tested, and reused as fully-warrantied service parts. Used Mopier parts are not placed into new product manufacturing. The remainder of the product parts are recycled, if possible. For product take-back information, contact your local HP Sales and Service Office.

Paper

The Mopier is suited for the use of recycled papers when the paper meets the guidelines outlined in the *HP LaserJet Printer Family Paper Specifications Guide*. The Mopier is suited for the use of recycled paper according to DIN 19 309.

Acoustics

It is advisable to place printers with a sound power level of Lwad of 6.3 Bel (A) or higher into a separate or divided up room.

Declarations of Conformity

Table 1-6. Declaration of Conformity (HP Mopier 320)

according to ISO/IEC Guide 22 and EN 45014

Manufacturer's Name: Hewlett-Packard Company

Manufacturer's Address: 11311 Chinden Boulevard

Boise, Idaho 83714-1021, USA

declares, that the product

Product Name: HP Mopier 320

Model Number: C4229A

Product Options: ALL

conforms to the following Product Specifications:

Safety: IEC 950:1991+A1+A2+A3+A4/ EN 60950:1992+A1+A2+A3+A4

IEC 825-1:1993/EN 60825-1:1994 Class 1 (Laser/LED)

EMC: CISPR 22:1993 / EN 55022:1994 Class B¹⁾

Table 1-7. Declaration of Conformity (HP Digital Copy 320)

according to ISO/IEC Guide 22 and EN 45014

Manufacturer's Name: Hewlett-Packard Company

Manufacturer's Address: 11311 Chinden Boulevard
Boise, Idaho 83714-1021, USA

declares, that the product

Product Name: HP Digital Copier 320

Model Number: C4230A

Product Options: ALL

conforms to the following Product Specifications:

Safety: IEC 950:1991+A1+A2+A3+A4/ EN 60950:1992+A1+A2+A3+A4

IEC 825-1:1993/EN 60825-1:1994 Class 1 (Laser/LED)

EMC: CISPR 22:1993 / EN 55022:1994 Class A¹)

EN 50081-1:1992

EN 50082-1:1992

IEC 801-2:1991 / prEN 55024-2:1992 -3 kV CD, 8 kV AD

IEC 801-3:1984 / prEN 55024-3:1991 - 3 V/m

IEC 801-4:1988 / prEN 55024-4:1992 - 1.0 kV Power Lines
0.5 kV Signal Lines

FCC Title 47 CFR, Part 15 Class A² / ICES-002, Issue 2

Table 1-7. Declaration of Conformity (HP Digital Copy 320) (continued)

AS / NZS 3548:1995

Supplementary Information:

The product herewith complies with the requirements of the EMC Directive 89/336/EEC and the Low Voltage Directive 73/23/EEC, and carries the CE-Marking accordingly.

- 1) The product was tested in a typical configuration with Hewlett-Packard Personal Computer Systems.
- 2) This Device complies with part 15 of the FCC Rules. Operation is subject to the following two conditions: (1) this device may not cause harmful interference, and (2) this device must accept any interference received, including interference that may cause undesired operation

Boise, Idaho USA
June 03, 1998

- Australia Contact: Product Regulations Manager, Hewlett-Packard Australia Ltd., 31-41 Joseph Street, Blackburn, Victoria 3130, Australia.
- European Contact: Your Local Hewlett-Packard Sales and Service Office or Hewlett-Packard GmbH, Department HQ-TRE, Herrenberger Straße 130, D-71034 Böblingen (Germany) (FAX: +49-7031-14-3143).
- USA Contact: Product Regulations Manager, Hewlett-Packard Company, PO Box 15, Mail Stop 160, Boise, ID, 83707-0015 (Phone: 208-396-6000).

Safety Statements

Laser Safety Statement

The Center for Devices and Radiological Health (CDRH) of the U.S. Food and Drug Administration has implemented regulations for laser products manufactured since August 1, 1976. Compliance is mandatory for products marketed in the United States. The Mopier is certified as a "Class 1" laser product under the U.S. Department of Health and Human Services (DHHS) Radiation Performance Standard according to the Radiation Control for Health and Safety Act of 1968. Since radiation emitted inside the Mopier is completely confined within protective housings and external covers, the laser beam cannot escape during any phase of normal user operation.

WARNING!

Using controls, making adjustments, or performing procedures other than those specified in this user's guide may result in exposure to hazardous radiation.

Canadian DOC Regulations

Complies with Canadian EMC Class B requirements.

<<Conforme à la classe B des normes canadiennes de compatibilité électromagnétiques. << CEM>>.>>

VCCI Statement (Japan)

HP Mopier 320 (Model C4229A)

この装置は、情報処理装置等電波障害自主規制協議会（VCCI）の基準に基づくクラスB情報技術装置です。この装置は、家庭環境で使用することを目的としていますが、この装置がラジオやテレビジョン受信機に近接して使用されると、受信障害を引き起こすことがあります。取り扱い説明書に従って正しい取り扱いをして下さい。

HP Digital Copy 320 (Model C4230A)

この装置は、情報処理装置等電波障害自主規制協議会（VCCI）の基準に基づくクラスA情報技術装置です。この装置を家庭環境で使用すると電波妨害を引き起こすことがあります。この場合には使用者が適切な対策を講ずるよう要求されることがあります。

Korean EMI statement

HP Mopier 320 (Model C4229A)

사용자 안내문 (B급 기기)

이 기기는 비업무용으로 전자파장해 검정을 받은 기기로서, 주거지역에서는 물론 모든지역에서 사용할 수 있습니다.

HP Digital Copy 320 (Model C4230A)

사용자 안내문 (A급 기기)

이 기기는 업무용으로 전자파장해 검정을 받은 기기 이오니, 만약 잘못 구입하셨 을 때에는구입한 곳에 세 비업무용으로 교환하시기 바랍니다.

Laser Statement for Finland

LASERTURVALLISUUS

LUOKAN 1 LASERLAITE

KLASS 1 LASER APPARAT

HP Mopier 320-laserkirjoitin on käyttäjän kannalta turvallinen luokan 1 laserlaite. Normaalisissa käytössä kirjoittimen suojakotelointi estää lasersäteen pääsyn laitteen ulkopuolelle.

Laitteen turvallisuusluokka on määritetty standardin EN 60825-1 (1993) mukaisesti.

VAROITUS !

Laitteen käyttäminen muulla kuin käyttöohjeessa mainitulla tavalla saattaa altistaa käyttäjän turvallisuusluokan 1 ylittävälle näkymättömälle lasersäteilylle.

VARNING !

Om apparaten används på annat sätt än i bruksanvisning specificerats, kan användaren utsättas för osynlig laserstrålning, som överskrider gränsen för laserklass 1.

HUOLTO

HP Mopier 320-kirjoittimen sisällä ei ole käyttäjän huollettavissa olevia kohteita. Laitteen saa avata ja huoltaa ainoastaan sen huoltamiseen koulutettu henkilö. Tällaiseksi huoltotoimenpiteeksi ei katsota väriainekasetin vaihtamista, paperiradan puhdistusta tai muita käyttäjän käsikirjassa lueteltuja, käyttäjän tehtäväksi tarkoitettuja ylläpitotoimia, jotka voidaan suorittaa ilman erikoistyökaluja.

VARO !

Mikäli kirjoittimen suojakotelo avataan, olet alttiina näkymättömälle lasersäteilylle laitteen ollessa toiminnassa. Älä katso säteeseen.

VARNING !

Om laserprinterns skyddshölje öppnas då apparaten är i funktion, utsätts användaren för osynlig laserstrålning. Betrakta ej strålen.

Tiedot laitteessa käytettävän laseriodin säteilyominaisuuksista:

Aallonpituus 770-795 nm

Teho 5 mW

Luokan 3B laser

2 Site Requirements

Chapter Contents

Operating Environment-	-46
Space Requirements-	-47
Environmental Requirements-	-50
Specifications	-51

Operating Environment

The electrical specifications listed in Table 2-4 on page 53 must be maintained to ensure proper operation of this Mopier. Consider the following points before installing the Mopier.

- Install the Mopier in a well-ventilated, dust-free area, away from any open windows.
- Install the Mopier and peripherals on a hard, flat and continuous surface, with all feet level. Do not install on carpet or other soft surfaces. We recommend the use of the HP Digital Copy 320 with the HP Digital Copy 320 Stand.
- Ensure adequate, stable power is supplied. Mopier power requirements are listed in table 2-4, “Electrical Specifications,” on page 53.
- Install the Mopier where there is stable temperature and humidity, away from water sources, humidifiers, air conditioners, refrigerators, or other major appliances (see table 2-1 on page 50).
- Install the Mopier away from direct sunlight, open flames, or chemicals. If the Mopier is placed near a window, make sure the window is closed and has a curtain or blind to block any direct sunlight.
- Install the Mopier with enough space around the Mopier for proper access and ventilation (see “Space Requirements” on page 47).
- Install the Mopier away from the direct flow of exhaust from air ventilation, heating, or air conditioning systems.

Note

Be sure to leave enough space to completely extend the optional output accessory away from the Mopier.

Space Requirements

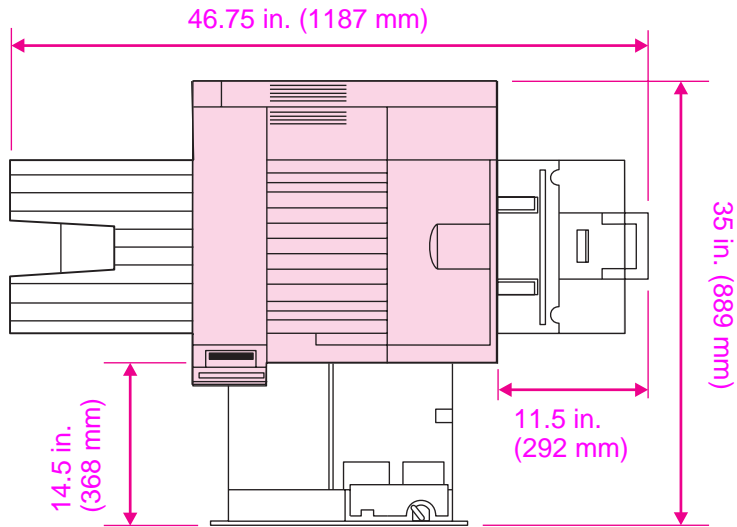

Figure 2-1 Mopier Space Requirements (Top view)

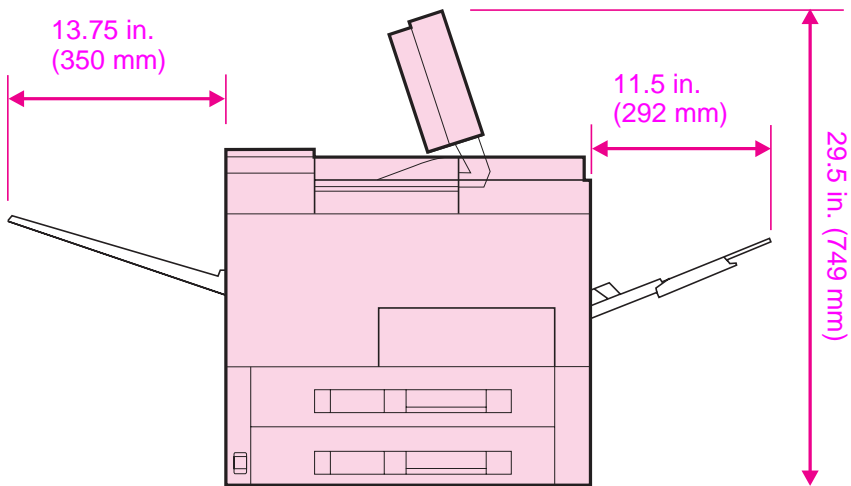

Figure 2-2 Mopier Space Requirements (Side view)

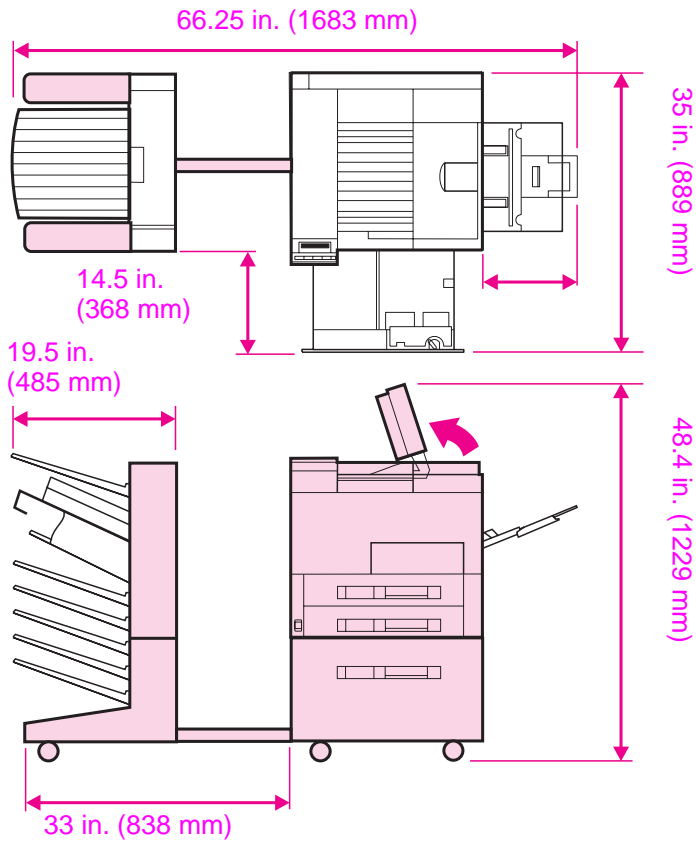

Figure 2-3 Mopier Space Requirements (with Mailbox and Input Device)

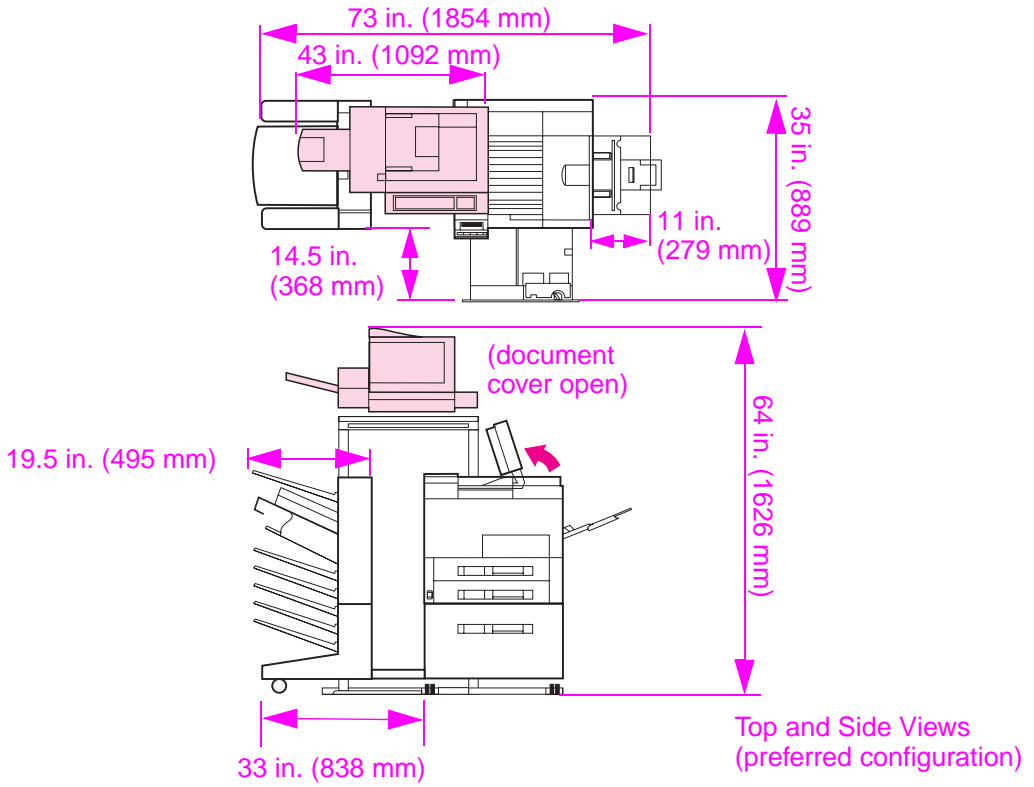

Figure 2-4 Mopier and Copy Module Space requirements

Environmental Requirements

Keep the Mopier within the following environmental conditions for optimum performance.

Table 2-1. Mopier and Toner Cartridge Environmental Conditions

	Operating	Storage
Temperature	10° to 32.5° C (50° to 90.5° F)	0° to 40° C (32° to 105° F)
Humidity	20 to 80% RH (with no condensation)	15 to 90% RH (with no condensation)

For printer weights, see table 2-2, “Dimensions of Mopier and Paper-handling Devices,” on page 51.

Specifications

Mopier and Paper-handling Devices

This section contains information on physical and electrical characteristics of the printer. For information on the printer site and environmental requirements (such as operating temperature and humidity, ventilation, etc.), see Chapter 2.

Table 2-2. Dimensions of Mopier and Paper-handling Devices

Item	Height	Width	Depth	Weight
Mopier only	21.30 in. (541 mm)	22.3 in. (566.42 mm)	20.50 in. (520 mm)	106 lbs. (48 kg) (without toner cartridge and with paper trays)
Mopier with 2 x 500-sheet Input Tray or 2000-sheet Input Tray	40.20 in. (1021 mm)	24.76 in. (629 mm)	20.50 in. (520 mm)	160-164 lbs. (72.6-74.4 kg)
Toner cartridge	n/a	n/a	n/a	¹ Full: 114.3 oz (3,200 g) Empty: 78.6 oz (2,200 g)
2 x 500-sheet Input Tray	18.89 in. (480 mm) Including Transfer Door: 25.59 in. (650 mm)	24.76 in. (629 mm)	20.50 in. (520 mm)	61 lbs. (27.9 kg.) without paper
2000-sheet Input Tray	18.89 in. (480 mm) Including Transfer Door: 25.59 in. (650 mm)	24.76 in. (629 mm)	20.50 in. (520 mm)	65 lbs. (29.5 kg)

1. Some toner will reside in the waste toner area of a toner cartridge when the toner supply is exhausted. Therefore toner cartridge weight may be an unreliable indication of remaining toner supply.

Table 2-3. Dimensions of Output Devices

Item	Height	Width	Depth	Weight
8-bin Mailbox	35.23 in. (895 mm)	18.0 in. (457 mm)	20.0 in. (508 mm)	42.32 lbs. (19.2 kg)
Stapler	14.17 in. (360 mm)	19.68 in. (500 mm)	14.56 in. (370 mm)	10.50 lbs. (4.8 kg)
Duplexer	37.40 in. (950 mm)	15.31 in. (389 mm)	16.73 in. (425 mm)	7.93 lbs. (3.6 kg)
Envelope Feeder	5.11 in. (130 mm)	15.31 in. (389 mm)	14.37 in. (365 mm)	7.71 lbs. (3.5 kg)
7-bin Tabletop Mailbox	20.87 in. (530 mm)	15.0 in. (381 mm)	18.50 in. (470 mm)	30 lbs. (14 kg.)
Stand (only for the 7-bin Tabletop Mailbox)	18.90 in. (480 mm)	16.90 in. (430 mm)	18.90 in. (480 mm)	32.00 lb. (14.5 kg)

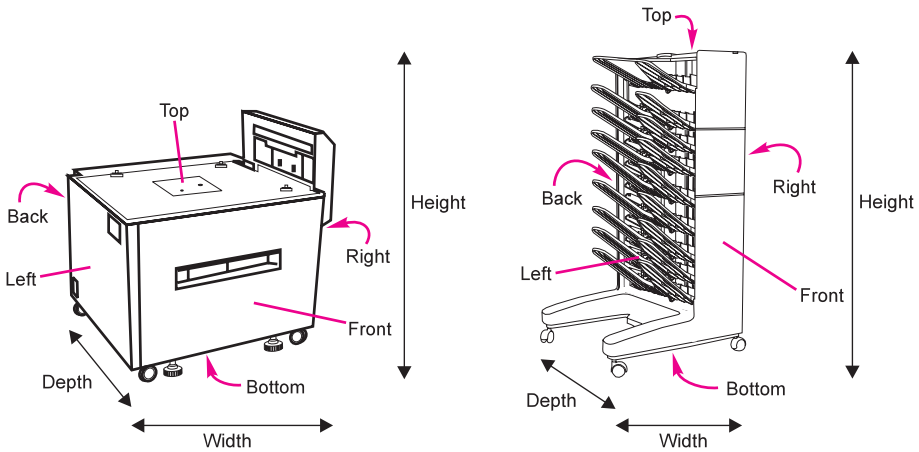

Figure 2-5 Dimensions of Paper Handling Devices

Table 2-4. Electrical Specifications

Volts	Frequency	Amps ¹	Watts (average)
Mopier			
120 Vac ± 10% 100 Vac ± 10%	50/60 Hz ± 2 Hz 50/60 Hz ± 2 Hz	11.2 maximum, 6.0 average	printing = 710 standby= 155 PowerSave Mode = 45
220 Vac ± 10% 240 Vac ± 10%	50 Hz ± 2 Hz 50 Hz ± 2 Hz	5.9 maximum, 3.0 average	printing = 700 standby= 155 PowerSave Mode = 45
2000-sheet Input Tray (Tray 4)			
120 Vac ± 10%	50/60 Hz ± 2 Hz	0.5 maximum, 0.3 average	45 Watts Maximum
240 Vac ± 10%	50/60 Hz ± 2 Hz	0.3 maximum, 0.2 average	45 Watts Maximum
8-bin Mailbox/5-bin Mailbox with Stapler			
100-240 Vac	50/60 Hz ± 2 Hz	0.5 @ 120v 0.25 @ 240v	45 Watts Maximum
2 x 500-sheet Input Tray (Trays 4 and 5)			
120 Vac ± 10%	50/60 Hz ± 2 Hz	0.9 maximum	47 Watts Maximum
240 Vac ± 10%	50/60 Hz ± 2 Hz	0.5 maximum	47 Watts Maximum

Table 2-4. Electrical Specifications (continued)

Volts	Frequency	Amps ¹	Watts (average)
7-bin Tabletop Mailbox			
120 Vac ± 10%	50/60 Hz ± 2 Hz	0.5 maximum	28 Watts Maximum
240 Vac ± 10%	50/60 Hz ± 2 Hz	0.3 maximum	28 Watts Maximum

1. Operating current requirements.

Table 2-5. Acoustic Emissions

Operation position per ISO 9296		Printer (stand-alone)	Printer System ¹
Printing	LPA dB(A)	59 db	62 db
Standby	LPA dB(A)	41 db	44 db
Bystander 1m per ISO 9296			
Printing	LPA dB(A)	53 db	56 db
Standby	LPA dB(A)	36 db	39 db
Sound Power per ISO 9296			
Printing	LWAD	6.9 bels (A)	7.2 bels (A)
Standby	LWAD	5.2 bels (A)	5.5 bels (A)

1. Printer System includes the 2000-sheet Input Tray (Tray 4) or 2 x 500-sheet Input Tray (Trays 4 and 5), 8-bin Mailbox/5-bin Mailbox with Stapler, Duplexer, and Envelope Feeder.

Note

Printer system values are an estimate determined from the baseline values.

Copy Module

Table 2-6. Specifications for Copy Module

Item		Specification		
Dimensions (mm)		Width: 43 in. (1092 mm)	Depth: 26 in. (660 mm)	Height: 22 in. (559 mm)
Weight		49 lb. (22 kg)		
Input power	Voltage and frequency	100 to 120 Volts $\pm 10\%$, 50 or 60 Hz ± 2 Hz 127 Volts, 60 Hz NOM or 220 to 240 Volts $\pm 10\%$, 50 Hz ± 2 Hz 220 Volts $\pm 10\%$, 60 Hz ± 2 Hz		
	Phases	Single Phase		
Power consumption		approximately 30 Watts		
Environmental condition	Device status	Operating	Not Operating	
	Temperature	50° F to 91° F (10° C to 32.5° C)	32° F to 95° F (0° C to 35° C)	
	Humidity (no condensation)	20% to 80% RH	10% to 90% RH	

3 Operating Overview

Chapter Contents

HP Mopier 320

Using the Mopier Control Panel- - - - -	-58
Performing a Cold Reset - - - - -	-62
Control Panel Menus- - - - -	-65
Mopier Service Mode - - - - -	-85
Testing the Mopier - - - - -	-89

HP Digital Copy 320

Using the HP Digital Copy 320 Front Panel - - - - -	-90
Copy Module Service Mode - - - - -	105
HP Resource Manager - - - - -	107

Using the Mopier Control Panel

Control Panel Layout

The control panel contains a 2-line, 16-character-per-line display panel, six keys, and three indicator lights.

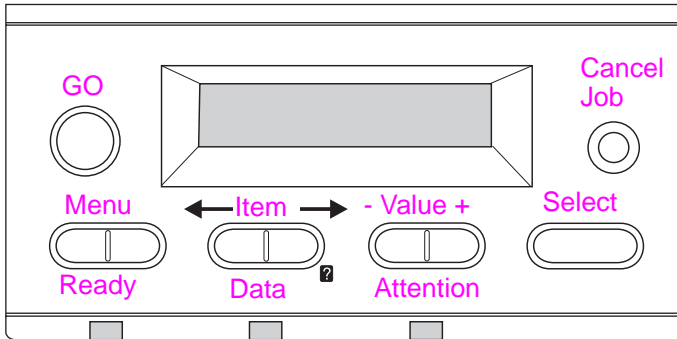

Figure 3-1 Control Panel Layout

Table 3-1. Control Panel Keys

Key	Function
Go	<ul style="list-style-type: none"> ● Places the mopier either online or offline. ● Prints any data residing in the mopier's buffer. ● Allows the mopier to resume printing after being offline. Clears most mopier messages and places the mopier online. ● Allows the mopier to continue printing with an error message such as TRAY x LOAD [TYPE] [SIZE] or UNEXPECTED PAPER SIZE. ● Confirms a manual feed request if Tray 1 is loaded and TRAY 1 MODE= CASSETTE has been set from the Paper Handling Menu in the mopier's control panel. ● Overrides a manual feed request from Tray 1 by selecting paper from the next available tray. ● Exits the control panel menus. (To save a selected control panel setting, first press SELECT.)
MENU	Cycles through the control panel menus. Press the right end of the button to move forward or the left end of the button to move backward.

Table 3-1. Control Panel Keys (continued)

Key	Function
ITEM	Cycles through the selected menu's items. Press the right end of the button to move forward or the left end of the button to move backward. Menu items that appear depend on the options installed and the configuration of other menu choices.
<ITEM>?	Provides an online help tool with more details on display error messages. Cycles through the selected menu item's values. Press + to move forward or - to move backward.
-VALUE+	Cycles through the selected menu item's values. Press + to move forward or - to move backward.
SELECT	Saves the selected value for that item. An asterisk (*) appears next to the selection, indicating that it is the new default. Default settings remain when the printer is switched off or reset (unless you reset all factory defaults from the Resets Menu). Prints one of the printer information pages from the control panel.
CANCEL JOB	Cancels the print job that the mopier is processing. The time it takes to cancel depends on the size of the print job. (Press it only once.)

Indicator Lights

The control panel indicator lights are described in the following table.

Table 3-2. Indicator Lights

Indicator=	State	Explanation	Action
Ready	On	Ready to receive data.	No action required.
	Flashing	Going offline.	No action required.
	Off	Printer is offline.	Press Go to place printer online.
Data	On	Data is resident in the printer and processed as far as possible. More data is expected, but no activity on the channel at this time.	No action required.
	Flashing	Data is being received or processed.	No action required.
	Off	No data is being received or processed in the printer.	No action required.

Table 3-2. Indicator Lights (continued)

Indicator=	State	Explanation	Action
Attention	On	Catastrophic error. Printer system is halted.	Turn printer off, then on. If problem persists, see Chapter 7.
	Flashing	The printer needs attention.	Read and respond to display panel message.
	Off	There are no messages or error conditions requiring attention.	No action required.

Settings and Defaults

The printer makes most printing decisions based on either temporary settings or factory (permanent) defaults.

Note

Settings you send from software applications override printer defaults.

Temporary Settings are the values set for the current print job by your software application. Temporary settings remain in effect until the current print job is finished.

Control Panel Defaults are the values entered by selecting a control panel item and pressing **SELECT**. An asterisk (*) next to the item name indicates that it is now the default. The printer retains default settings even when power is turned off.

Factory Defaults are the permanent default values for each menu item set at the factory. These values are listed in table 3-3 on page 63.

Printer Driver Information

When you change a setting from the printer control panel, the new setting becomes the printer default value. You can override any Printing Menu setting through most software applications and from the printer driver.

Paper Source Default

The printer paper source is specified by the print job, not the printer control panel. The following paragraphs apply when the current job does not specify a paper source. Unless changed or not specified by the current job, the software application, or the printer driver, the paper source default is determined by the “Cold Reset Paper Size” (letter or A4) set in the Service Mode Menu.

- If Tray 1 is set to cassette, it will look for the default size.
- If there is no paper in Tray 1, and Tray 4 of the 2000-sheet Input Tray is installed and loaded with the Cold Reset Paper Size, the printer will pull from Tray 4.
- The printer pulls paper from Tray 5 first if the Optional 2 x 500-sheet Input Tray is installed.
- If there is no paper in Tray 1, and Tray 4 is not installed, the printer will pull from the first tray containing the Cold Reset Paper Size.
- If none of the trays contain the Cold Reset Paper Size, the printer will prompt the user to put letter or A4 paper in Tray 1.

Performing a Cold Reset

Cold Reset

Cold Reset clears all data from the printer memory and sets all the defaults back to the factory settings.

CAUTION

Performing a Cold Reset resets the JetDirect configuration. To avoid making changes to your configuration, remove the JetDirect card before performing a Cold Reset.

If possible, print a Configuration Page prior to performing a Cold Reset. This will document current settings for later reference.

To perform a Cold Reset:

1. Turn off the printer.
2. While pressing **Go**, turn the printer on. `COLD RESET` appears briefly on the display, then `INITIALIZING` appears. After a few seconds, `RESTORING FACTORY SETTINGS` appears on the display, followed by `OFFLINE`. The Cold Reset is complete.
3. Press **Go** to return the printer online. `READY` appears on the display.

Setting the Display Language

- 1 Press and hold **SELECT** while powering on. Hold **SELECT** until `SELECT LANGUAGE` appears.
- 2 Release **SELECT**. `INITIALIZING` appears briefly. Wait for `LANGUAGE=ENGLISH` to appear.
- 3 Press **+** repeatedly until the desired language appears.
- 4 Press **SELECT** to save your choice. An asterisk (*) will appear beside your language selection.
- 5 Press **Go** to return to a `READY` state.

Note

The language that appears on the HP Digital Copy 320 display is customized through the language selected on the Mopier. If the Mopier language is set to a language other than the six offered by the HP Digital Copy 320, then the HP Digital Copy 320 will default to English. (See the Mopier online user guide for more information.)

Table 3-3. Factory Default Settings

APPEND CR TO LF	NO
AUTO CONTINUE=	ON
CFG NETWORK	NO
CLEARABLE WARNINGS	JOB
CONFIGURE CUSTOM PAPER	NO
CONFIGURE FUSER MODE	NO
COPIES	1
COURIER	REGULAR
CREATE CLEANING PAGE	NO
DUPLEX=	OFF
ECONOMODE=	OFF
FORM	60 LINES
I/O TIMEOUT=	15 SECONDS
IO BUFFER=	AUTO
JAM RECOVERY=	AUTO
MANUAL FEED	OFF
NEW TONER CARTRIDGE	NO
ORIENTATION=	PORTRAIT
OVERRIDE A4/LETTER	NO
PAPER DEST=	STANDARD OUTPUT BIN
PAPER=	LETTER
PARALLEL ADV FUNCTIONS	ON
PARALLEL HIGH SPEED SETTING=	YES
PCL FONT NUMBER	0
PCL FONT PITCH	10
PCL FONT SOURCE	INTERNAL
PCL SYMBOL SET	PC-8
PERSONALITY=	AUTO
POWERSAVE ON=	1 HOUR

Table 3-3. Factory Default Settings (continued)

PRINT PS ERRORS	OFF
RAM DISK	AUTO
RAM DISK SIZE	800K
RESOLUTION=	FASTRES 1200
RESOURCE SAVE=	OFF
RET=	MEDIUM
TONER DENSITY=	3
TONER LOW=	CONTINUE
TRAY 1 MODE	FIRST
TRAY 2 TYPE	PLAIN
TRAY 3 TYPE	PLAIN
WIDE A4	NO

Control Panel Menus

Press **MENU** to cycle through the control panel menus. Each menu is described in a separate table in this section. Figure 7-15 on page 588 provides a map of all the menus and their associated items. Menu items are displayed only if their associated option is installed, or their function is activated.

All menus and their associated items are accessible when the printer is online. In menu mode, if no keys are pressed for approximately 30 seconds, the system will automatically return to the top level and display either an existing error, or one of the following:

- **READY**, if the printer was online.
- **OFFLINE**, if the printer was offline.

To select a menu item

- 1 Press **MENU** repeatedly until the desired menu appears.
- 2 Press **ITEM** repeatedly until the desired item appears.
- 3 Press **+** repeatedly (or hold down **+** to scroll) until the desired setting appears.
- 4 Press **SELECT** to save the selection. An asterisk (*) appears next to the selection, indicating that it is now the default.
- 5 Press **MENU** or **GO** to exit the menus.

Note

Shaded items appear only if the associated option or function is installed and activated.

Quick Copy Jobs Menu

This menu provides a list of the quick copy jobs stored on the printer's hard disk. The user can print or delete these jobs from the control panel.

Note

If there are no quick copy jobs stored on the printer's hard disk, this menu is not displayed on the control panel.

Table 3-4. Quick Copy Jobs Menu

Item	Value	Explanation
[USERNAME]		The name of the person who owns the quick copy job.
COPIES=1	1 to 999 DELETE	The number of additional copies the user wants to print. 1-999: Prints the requested number of copies of the job. DELETE: Deletes the job from the printer's hard disk.

Private/Stored Jobs Menu

This menu provides a list of the private and stored jobs on the printer's hard disk. The user can print or delete these jobs from the control panel.

Note

If there are no private and stored jobs on the printer's hard disk, this menu is not displayed on the control panel.

Table 3-5. Private/Stored Jobs Menu

Item	Value	Explanation
[JOBNAME]		The name of the job stored on the printer's hard disk.
PIN:0000		To print the job, the user must enter the Personal Identification Number (PIN) assigned to the job in the driver.
COPIES=1	1 to 999 DELETE	The number of additional copies the user wants to print. 1-999: Prints the requested number of copies of the job. DELETE: Deletes the job from the printer's hard disk.

Note

The Quick Copy Jobs Menu and the Private/Stored Jobs Menu will only appear if you have a Hard Disk, if you have selected a Job Retention Option, and if you have sent jobs to the printer.

Information Menu

This menu contains printer information pages that give details about the printer and its configuration. To print a page from the information menu, scroll to the desired page and press **SELECT**.

Table 3-6. Information Menu

Item	Explanation
PRINT MENU MAP	The menu map shows the layout and current settings of the control panel menu items.
PRINT CONFIGURATION	The configuration page shows the printer's current configuration. If an HP JetDirect print server card is installed, a JetDirect configuration page will print out as well.
PRINT PCL FONT LIST	The PCL font list shows all the PCL fonts currently available to the printer.
PRINT PS FONT LIST	The PS font list shows all the PS fonts currently available to the printer.
PRINT FILE DIRECTORY	The file directory shows information for all of the installed mass storage devices.
PRINT EVENT LOG	The event log lists printer events or errors.
SHOW EVENT LOG	This item allows you to view the most recent printer events on the control panel display. Press - VALUE + to scroll through the event log entries.
PRINT PAPER PATH TEST	The paper path test can be used to verify that the paper path is working properly, or to troubleshoot problems with a type of paper. Choose the input tray, output bin, duplexer (if available), and number of copies. NOTE: Feeding paper from Tray 1 will not allow the user to send paper to the Face-down output bins during this test.
PRINT USAGE PAGE	Only shown when hard disk is installed. Primarily used for Mopier page tracking.

Paper Handling Menu

When paper handling settings are correctly configured through the control panel, you can print by choosing the type and size of paper from the printer driver or software application.

Some items in this menu (such as duplex and manual feed) can be accessed from a software application, or from the printer driver (if the appropriate driver is installed). Printer driver and software application settings override control panel settings.

Table 3-7. Paper Handling Menu

Item	Values	Explanation
TRAY 1 MODE= FIRST	FIRST CASSETTE	Determine how the printer will use Tray 1. FIRST: If paper is loaded in Tray 1, the printer will pull paper from that tray first. CASSETTE: A paper size must be assigned to Tray 1 using the TRAY 1 SIZE option (the next item in this menu when TRAY 1 MODE=CASSETTE). This allows Tray 1 to be used as a reserved tray.
TRAY 2 TYPE= PLAIN	For supported paper types, see table 1-2.	Set the value to correspond with the paper type currently loaded in Tray 2.
TRAY 3 TYPE= PLAIN	For supported paper types, see table 1-2.	Set the value to correspond with the paper type currently loaded in Tray 3.
*TRAY 4 TYPE= PLAIN	For supported paper types, see table 1-2.	Set the value to correspond with the paper type currently loaded in the Optional 2000-sheet Input Tray (Tray 4) or Tray 4 of the Optional 2 x 500-sheet Input Tray (Trays 4 and 5).
*TRAY 5 TYPE= PLAIN	For supported paper types, see table 1-2.	Set the value to correspond with the paper type currently loaded in Tray 5 of the Optional 2 x 500-sheet Input Tray (Trays 4 and 5).
PAPER DEST= STANDARD OUTBIN	STANDARD OUTBIN LEFT OUTBIN OPTIONAL BIN	This item appears when an output device is installed. Set the value to correspond to the appropriate bin. Additional output bins appear in the menu with the installation of output devices.
MANUAL FEED=OFF	OFF ON	Feed the paper manually from Tray 1, rather than automatically from a tray. When MANUAL FEED=ON and Tray 1 is empty, the printer goes offline when it receives a print job and displays MANUALLY FEED [PAPER SIZE].

Table 3-7. Paper Handling Menu (continued)

Item	Values	Explanation
*DUPLEX=OFF	OFF ON	This item appears only when a duplexer is installed. Set the value to ON to print on both sides (duplex) or OFF to print on one side (simplex) of a sheet of paper.
OVERRIDE A4/LETTER=NO	NO YES	Choose YES to print on letter-size paper when an A4 job is sent, but no A4-size paper is loaded in the printer (or to print on A4-size paper when a letter job is sent, but no letter paper is loaded in the printer).
CONFIGURE FUSER MENU	NO YES	Default is NO. Choose YES to configure. Press - VALUE + or to make your selection, and press SELECT to save the setting. NORMAL = 32 ppm. LOW = slightly lower temperature at 32 ppm. HIGH1 = slightly higher than normal at 32 ppm. HIGH2 = slightly higher than normal at 24 ppm. This allows more time to fuse toner for special types of media (i.e. heavy, rough stock) HIGH3 = slightly hotter fusing than H1 or H2 at 16 ppm, for media needing more time in the fusing process.

Note

Items marked with an * only appear in the menu if the 2 x 500-sheet Input Tray, the 2000-sheet Input Tray, or the duplexer are installed.

To see the default fuser mode for each paper type, select YES, scroll back to the Information Menu, and print a menu map.

Print Quality Menu

Some items in this menu can be accessed from a software application, or from the printer driver (if the appropriate driver is installed). Printer driver and software application settings override control panel settings.

Table 3-8. Print Quality Menu

Item	Values	Explanation
RESOLUTION= FASTRES 1200	300 600 FASTRES 1200	<p>Select the resolution from the following values:</p> <p>300: Produces draft print quality at the printer's maximum speed (32 ppm). 300 dpi (dots per inch) is recommended for some bitmapped fonts and graphics, and for compatibility with the HP LaserJet III family of printers.</p> <p>600: Produces high print quality at the printer's maximum speed.</p> <p>FASTRES 1200: Produces optimum print quality (comparable to 1200 dpi) at the printer's maximum speed.</p> <p>Note</p> <p>It is best to change the resolution from the printer driver or software application. (Driver and software settings override control panel settings.)</p>
RET=MEDIUM	OFF LIGHT MEDIUM DARK	<p>Use the printer's Resolution Enhancement technology (REt) setting to produce print with smooth angles, curves, and edges.</p> <p>All print resolutions, including FastRes 1200, benefit from REt.</p> <p>Note</p> <p>It is best to change the REt setting from the printer driver or software application. (Driver and software settings override control panel settings.)</p>

Table 3-8. Print Quality Menu (continued)

Item	Values	Explanation
ECONOMODE=OFF	OFF ON	<p>Turn EconoMode on (for draft mode) or off (for high quality). EconoMode creates draft-quality printing by reducing the amount of toner on the printed page by up to 50%.</p> <p>CAUTION HP does not recommend full-time use of EconoMode. (If EconoMode is used full-time, it is possible that the toner supply will outlast the mechanical parts in the toner cartridge.)</p> <p>Note It is best to turn EconoMode on or off from the printer driver or software application. (Driver and software settings override control panel settings.)</p>
TONER DENSITY=3	1 2 3 4 5	<p>Lighten or darken the print on the page by changing the toner density setting. The settings range from 1 (light) to 5 (dark), but the default setting of 3 usually produces the best results.</p> <p>Use a lower toner density setting to save toner.</p> <p>Note It is best to change the toner density from the printer driver or software application. (Driver and software settings override control panel settings.)</p>
CREATE CLEANING PAGE	No value to select.	<p>Press SELECT to print a cleaning page (for cleaning excess toner from the paper path). In order for the cleaning page to work properly, print the page on copier grade paper (not bond or rough paper). Follow the instructions on the cleaning page.</p>

Printing Menu

Some items in this menu can be accessed from a software application, or from the printer driver (if the appropriate driver is installed). Printer driver and software application settings override control panel settings.

Table 3-9. Printing Menu

Item	Values	Explanation
COPIES=1	1 to 999	<p>Sets the default number of copies by selecting any number from 1 to 999. Press - VALUE + once to change the setting by increments of 1, or hold down - VALUE + to scroll by increments of 10.</p> <p>Note It is best to set the number of copies from the printer driver or software application. (Driver and software settings override control panel settings.)</p>
PAPER= LETTER	For supported paper types, see table 1-2.	<p>Sets the default image size for paper and envelopes. (The item name will change from paper to envelope as you scroll through the available sizes.)</p> <p>Note The defaults indicated here are for 110V printers. The default paper size for 220V printers is A4. The default envelope size for 220V printers is DL.</p>
CONFIGURE CUSTOM PAPER=NO	NO YES	<p>NO: The custom paper menu items are not accessible. YES: This menu item allows the user to configure a custom size when printing from Tray 1. The increments can be set to inches or millimeters.</p>
FORM=60 LINES	5 to 128	<p>Sets vertical spacing from 5 to 128 lines for default paper size. Press - VALUE + once to change the setting by increments of 1, or hold down - VALUE + to scroll by increments of 10.</p>

Table 3-9. Printing Menu (continued)

Item	Values	Explanation
ORIENTATION=	PORTRAIT LANDSCAPE	Determines the default orientation of print on the page. Note It is best to set the page orientation from the printer driver or software application. (Driver and software settings override control panel settings.)
PCL FONT SOURCE=INTERNAL	INTERNAL SOFT SLOT 1, 2, or 3	INTERNAL: Internal fonts. SOFT: Permanent soft fonts. SLOT 1, 2, or 3: Fonts stored in one of the three DIMM slots.
PCL FONT NUMBER=	0 to 999	The printer assigns a number to each font and lists them on the PCL Font List. The font number appears in the Font # column of the printout.
PCL FONT PITCH=	0.44 to 99.99	This item might not appear, depending on the font selected. Press - VALUE + once to change setting by increments of 0.01 for pitch, or hold down - VALUE + to scroll by increments of 1.
PCL SYMBOL SET=PC-8	PC-8 many others	Select any one of several available symbol sets from the printer's control panel. A symbol set is a unique grouping of all the characters in a font. PC-8 or PC-850 is recommended for line draw characters.
COURIER=REGULAR	REGULAR DARK	Select the version of Courier font to use: REGULAR: The internal Courier font available on the HP LaserJet 4 series printers. DARK: The internal Courier font available on the HP LaserJet III series printers. Both fonts are not available at the same time.

Table 3-9. Printing Menu (continued)

Item	Values	Explanation
WIDE A4=NO	NO YES	The Wide A4 setting changes the number of characters that can be printed on a single line of A4 paper. NO: Up to 78 10-pitch characters can be printed on one line. YES: Up to 80 10-pitch characters can be printed on one line.
APPEND CR TO LF= NO	NO YES	Select YES to append a carriage return to each line feed encountered in backward-compatible PCL jobs (pure text, no job control). Some environments, such as UNIX, indicate a new line using only the line feed control code. This option allows the user to append the required carriage return to each line feed.
PRINT PS ERRORS=OFF	OFF ON	Select ON to print the PS error page when PS errors occur.

Configuration Menu

Items in this menu affect the printer's behavior. Configure the printer according to your printing needs.

Table 3-10. Configuration Menu

Item	Values	Explanation
POWERSAVE ON= 1 HOUR	OFF 15 MINUTES 30 MINUTES 1 HOUR 2 HOURS 3 HOURS	<p>Set the printer to enter PowerSave after it has been idle for a specified amount of time. Turning PowerSave off is not recommended. The PowerSave feature does the following:</p> <ul style="list-style-type: none">Minimizes the amount of power consumed by the printer when it is idle.Reduces wear on the printer's electronic components. (Turns off the display's backlight.) <p>When you send a print job, press a control panel key, open a paper tray, or open the top cover, the printer automatically comes out of PowerSave mode.</p> <p>Note</p> <p>PowerSave turns off the backlight on the display, but the display is still readable.</p>
PERSONALITY= AUTO	AUTO PCL PS	<p>Select the default printer language (personality). Normally you should not change the printer language (the default is AUTO). If you change it to a specific printer language, the printer will not automatically switch from one language to another unless specific software commands are sent to the printer.</p>

Table 3-10. Configuration Menu (continued)

Item	Values	Explanation
<p>RESOURCE SAVE= OFF</p>	<p>OFF ON AUTO</p>	<p>This item dedicates printer memory to save each language's permanent resources. (You might need to add memory to the printer in order for this item to appear.) The amount of memory set aside can be different for each installed language. Some languages might have memory set aside for resource saving without requiring all languages to do so. Any time the amount of memory dedicated to a specific language is changed, all languages will lose all saved resources, including any unprocessed print jobs.</p> <p>OFF: No language resource saving is performed, and language-dependent resources, such as fonts and macros, are lost when language or resolution changes.</p> <p>ON: An item will appear for each installed language that allows the user to allocate a particular amount of memory to that language's resource saving area. (See the items below.)</p> <p>AUTO: The printer automatically determines the amount of memory to use for each installed language's resource saving area.</p>
<p>PCL MEMORY+ 400K</p>	<p>@K and up (This value depends on the amount of installed memory.)</p>	<p>This item appears only when RESOURCE SAVE=ON. Select the amount of memory used for saving PCL resources. Printer default is the minimum amount of memory needed to perform resource saving for PCL. Press - VALUE + to change settings by increments of 10 (up to 100KB) or by increments of 100 (above 100KB).</p>
<p>PS MEMORY= 400K</p>	<p>@K and up (This value depends on the amount of installed memory.)</p>	<p>This item appears only when RESOURCE SAVE=ON. Select the amount of memory used for saving PS resources. Printer default is the minimum amount of memory needed to perform resource saving for PCL. Press - VALUE + to change settings by increments of 10 (up to 100KB) or by increments of 100 (above 100KB).</p>

Table 3-10. Configuration Menu (continued)

Item	Values	Explanation
PAGE PROTECT= AUTO	AUTO ON	This item appears only after a 21 PAGE TOO COMPLEX; PRESS GO TO CONTINUE message displays. Memory Enhancement technology (MEt) attempts to guarantee that all pages will print. If the page does not print, turn PAGE PROTECT to ON. This might increase chances of a 20 INSUFFICIENT MEMORY; PRESS GO TO CONTINUE message. If this occurs, simplify the print job or install additional memory.
CLEARABLE WARNINGS=JOB	JOB ON	Set the amount of time that a clearable warning is displayed on the printer's control panel. JOB: Warning messages display on the control panel until the end of the job from which they were generated. ON: Warning messages display on the control panel until Go is pressed.
AUTO CONTINUE= ON	ON OFF	This item determines how the printer reacts to errors. ON: If an error occurs that prevents printing, the message will display, and the printer will go offline for 10 seconds before returning online. OFF: If an error occurs that prevents printing, the message will remain on the display and the printer will remain offline until Go is pressed.
TONER LOW=CONTINUE	CONTINUE STOP	This item determines how the printer behaves when toner is low. The TONER LOW message will first appear when the toner cartridge is almost out of toner. (About 100 to 300 images can still be printed.) CONTINUE: The printer will continue to print while the TONER LOW message is displayed. STOP: The printer will go offline and wait for further action.

Table 3-10. Configuration Menu (continued)

Item	Values	Explanation
RAM DISK=AUTO	ON OFF AUTO	<p>This item determines how the RAM disk is configured. This item appears only if there is no hard disk installed and the printer has at least 12 MB of memory.</p> <p>OFF: The RAM disk is disabled.</p> <p>ON: The RAM disk is enabled. Configure the amount of memory to be used with the item RAM DISK SIZE.</p> <p>Note</p> <p>If the setting is changed from OFF to ON or from OFF to AUTO, the printer will automatically reinitialize when it becomes idle.</p>
RAM DISK SIZE=xxxK	OK and up. (This value depends on the amount of installed memory.)	<p>This item determines the size of the RAM disk. This item appears if RAM DISK=ON or AUTO.</p> <p>Press - VALUE + to change settings by increments of 100.</p> <p>Note</p> <p>This setting cannot be changed if RAM DISK=AUTO. Changing this value will cause the printer to reinitialize when it becomes idle.</p>
JAM RECOVERY=AUTO	AUTO ON OFF	<p>This item determines how the printer behaves when a paper jam occurs.</p> <p>AUTO: The printer automatically selects the best mode for printer jam recovery (usually ON). This is the default setting.</p> <p>ON: The printer automatically reprints pages after a paper jam is cleared.</p> <p>OFF: The printer does not reprint pages following a paper jam. Printing performance might be increased with this setting.</p>

Table 3-10. Configuration Menu (continued)

Item	Values	Explanation
MAINTENANCE MESSAGE=OFF	OFF	This item appears only after the PERFORM PRINTER MAINTENANCE message displays. OFF: The PERFORM PRINTER MAINTENANCE message will be cleared. If you do not replace the maintenance kit, the PERFORM PRINTER MAINTENANCE message will be displayed again after approximately 17,500 pages. The message should not be turned off unless the printer maintenance has been performed. If the required maintenance is not performed, the printer's performance will degrade.
NEW TONER CARTRIDGE=NO	NO YES	YES: Resets the printer to recognize new cartridge, and resets the toner gauge on the configuration page.
QUICK COPY JOBS =32	1 to 50	Specifies the number of quick copy jobs that can be stored on the printer's hard disk.

I/O Menu

Items in the I/O (input/output) Menu affect the communication between the printer and the computer.

Table 3-11. I/O Menu

Item	Values	Explanation
I/O TIMEOUT=15	5 to 300	<p>Select the I/O time-out period in seconds. (I/O time-out refers to the time, measured in seconds, that the printer waits before ending a print job.)</p> <p>This setting allows you to adjust time-out for best performance. If data from other ports appear in the middle of your print job, increase the time-out value. Press - VALUE + once to change settings by increments of 1, or hold down - VALUE + to scroll by increments of 10.</p>
I/O BUFFER=AUTO	AUTO ON OFF	<p>Allocate memory for I/O buffering.</p> <p>AUTO: The printer automatically reserves memory for I/O buffering. Additional configurations are not required and the I/O BUFFER SIZE menu item does not appear.</p> <p>ON: The I/O BUFFER SIZE item appears (see below). Specify the amount of memory to be used for I/O buffering.</p> <p>OFF: I/O buffering is not performed and the I/O BUFFER SIZE item does not appear.</p> <p>When the I/O buffer setting is changed, any downloaded resources (such as fonts or macros) will need to be downloaded again, unless they are stored on the hard disk or a flash DIMM.</p>
PARALLEL HIGH SPEED=YES	YES NO	<p>Select the speed at which data is transmitted to the printer.</p> <p>YES: The printer accepts faster parallel communications used for connections with newer computers.</p> <p>NO: The printer accepts slower parallel communications used for connections with older computers.</p>

Table 3-11. I/O Menu (continued)

Item	Values	Explanation
PARALLEL ADV FUNCTIONS=ON	ON OFF	Turn the bidirectional parallel communication on or off. The default is set for a bidirectional parallel port (IEEE-1284). This setting allows the printer to send status messages to the computer. (Turning the parallel advanced functions on might slow language switching.)

EIO Menu

EIO (enhanced input/output) Menus depend on the particular accessory product installed in an EIO slot of the printer. If the printer contains an HP JetDirect print server EIO card, you can configure basic networking parameters using the EIO Menu. These and other parameters can also be configured through HP JetAdmin.

Table 3-12. EIO Menu

Item	Values	Explanation
CFG NETWORK=NO	NO YES	NO: The JetDirect Menu is not accessible. YES: The JetDirect Menu appears.
NOVELL=ON	ON OFF	Select whether the IPX/SPX protocol stack (in Novell NetWare networks, for example) is enabled (on) or disabled (off).
DLC/LLC=ON	ON OFF	Select whether the DLC/LLC protocol stack is enabled (on) or disabled (off).
TCP/IP=ON	ON OFF	Select whether the TCP/IP protocol stack is enabled (on) or disabled (off).
ETALK=ON	ON OFF	Select whether the Apple EtherTalk protocol stack is enabled (on) or disabled (off).

Table 3-12. EIO Menu (continued)

Item	Values	Explanation
CFG IPX/SPX=NO	NO YES	<p>NO: The IPX/SPX Menu is not accessible.</p> <p>YES: The IPX/SPX Menu appears. In the IPX/SPX Menu, you can specify the frame type parameter used on your network. The default is AUTO, to automatically set and limit the frame type to the one detected.</p> <p>For Ethernet cards, frame type selections include EN_8023, EN_LII, EN_8022, EN_SNAP.</p> <p>For Token Ring cards, frame type selections include TR_8022, TR_SNAP.</p> <p>In the IPX/SPX Menu for Token Ring cards, you can also specify NetWare Source Routing parameters, which include SRC_RT=AUTO (default), OFF, SINGLE R, or ALL RT.</p>
CFG TCP/IP=NO	NO YES	<p>NO: The TCP/IP Menu is not accessible.</p> <p>YES: The TCP/IP Menu appears. In the TCP/IP Menu, you can specify BOOTP=YES for TCP/IP parameters to be automatically loaded from a bootp or DHCP server when the printer is turned on. If you specify BOOTP=NO, you can manually set selected TCP/IP parameters from the control panel. You can manually set each byte of the IP address (IP), Subnet Mask (SM), Syslog Server (LG), and Default Gateway (GW). Also, you can manually set the Timeout time period.</p>
CFG ETALK=NO	NO YES	<p>NO: The EtherTalk Menu is not accessible.</p> <p>YES: The EtherTalk Menu appears. In the EtherTalk Menu you can set the AppleTalk phase parameter (ETALK PHASE=1 or 2) for your network.</p>

Resets Menu

CAUTION

Use this menu with caution. You can lose buffered page data or printer configuration settings when you select these items. Only reset the printer under the following circumstances:

- You want to restore the printer's default settings.
- Communication between the printer and computer has been interrupted.
- You are having problems with a port.

The items in the Resets Menu will clear all memory in the printer, while **CANCEL JOB** clears only the current job.

Table 3-13. Resets Menu

Item	Explanation
RESET MEMORY	This item clears the printer buffer and the active I/O input buffer, and makes the control panel defaults current. Resetting memory during a print job can result in data loss.
RESTORE FACTORY SETTINGS	This item performs a simple reset and restores most of the factory (default) settings. This item also clears the input buffer for the active I/O. Resetting memory during a print job can result in data loss.
RESET ACTIVE I/O CHANNEL	This item performs a simple reset and clears the input and output buffers (for the active I/Os only). Resetting memory during a print job can result in data loss.
RESET ALL I/O CHANNELS	This item performs a simple reset and clears the input and output buffers for all I/Os.

Mopier Service Mode

The Service Mode should be used only by authorized service personnel. While in Service Mode, you can:

- Verify and set the Page Count and serial number. These are displayed on the Configuration Page.
- Set the Cold Reset Paper Size Default. (This sets the factory default paper size to either Letter or A4.)
- Clear the Event Log.

Initiate the Service Mode as follows:

- 1 Hold down **SELECT** and **JOB CANCEL** while powering on the printer, until all lights are illuminated and the Display is blank. (If the Display Panel reads `INTERNAL TEST` at this point, the keys were released too soon. Repeat this step until successful.)
- 2 Press **MENU**, then **SELECT**. The message `SERVICE MODE` is displayed briefly, then the printer automatically begins an `INTERNAL TEST`. After several seconds, both Control Panel Indicators turn off. (The printer may display `WARMING UP` if it has not warmed up completely.) After the printer has warmed up and passed the self test, `SERVICE MODE` is displayed.
- 3 Press **MENU** once to display `SERVICE MENU`.

To exit the Service Mode press **GO**.

Table 3-14. Service Mode Menu Items

Service Mode Menu Items	Item Choices	Actions Required
PAGES=	0000000	<p>Displays total number of pages printed by the printer.</p> <p>Press + to step through values above cursor. Press SELECT to activate choice. Cursor will move to next digit.</p> <p>Printer will set new number into NVRAM after least significant digit is selected. Pressing MENU or ITEM before completing all digits will cancel the new setting.</p> <p>Pressing MENU returns printer to the main menu system. Pressing ITEM moves to the next menu item.</p>

Table 3-14. Service Mode Menu Items (continued)

Service Mode Menu Items	Item Choices	Actions Required
MAINTENANCE COUNT=	0000000	<p>Displays the page count when the next preventative maintenance should be performed (maintenance should be performed every 350,000 pages).</p> <p>Press + to step through values above cursor. Press SELECT to activate choice. Cursor will move to next digit.</p> <p>Printer will set new number into NVRAM after least significant digit is selected. Pressing MENU or ITEM before completing all digits will cancel the new setting.</p> <p>Pressing MENU returns printer to the main menu system. Pressing ITEM moves to the next menu item.</p>
MAINTENANCE INTERVAL=	350000	<p>Allows a service technician to change the page count when the PERFORM PRINTER MAINTENANCE 350,000 is the default value.</p> <p>This is provided for customers with printing environments that require more frequent maintenance cycles.</p>
SERIAL NUMBER=	xxxxxxxxxx	<p>Displays printer serial number (also located on the printer back cover).</p> <p>Press + to step through values above cursor. Press SELECT to activate choice. Cursor will move to next digit.</p> <p>Printer will set new number into NVRAM after least significant digit is selected. Pressing MENU or ITEM before completing all digits will cancel the new setting.</p> <p>Pressing MENU returns printer to the main menu system. Pressing ITEM moves to the next menu item.</p>
COLD RESET PAPER=	LETTER * A4	<p>Press + to change setting. Press SELECT to activate choice.</p>
DIAGNOSTICS=	OFF * ON	<p>For factory test purposes ONLY. DO NOT change.</p>
CLEAR EVENT LOG		<p>Press SELECT to activate. Printer returns to READY when completed.</p>

Setting Page Count, Maintenance Count, and Serial Number

The page count, maintenance count, and printer serial numbers are stored in Non-Volatile Memory. `PAGECOUNT` is the total number of images printed by the printer, `MAINTCOUNT` is the page count when the next preventative maintenance should be performed (every 350,000 images), and `SERIAL NUMBER=` is the printer serial number (also located on the printer back cover).

If it is necessary to replace the Formatter PCA, these numbers should be set to the current values to accurately reflect the age of the print engine. The procedures for setting these values are listed in table 3-14.

Before removing the old Formatter PCA, print a Configuration Page to verify the current values.

Note

If it is not possible to print a Configuration Page, try to verify the values before replacing the Formatter PCA by following steps 1 through 3, below.

After verifying the page count, maintenance count, and printer serial number from the old Formatter PCA, replace it with the new PCA.

- 1 Enter the Service Mode as previously described in this chapter.
- 2 When `SERVICE MODE` is displayed, press **MENU** to access the Service Menu.
- 3 Press **ITEM** to display `PAGECOUNT=`, `MAINTCOUNT=`, and `SERIAL NUMBER=`.
- 4 Enter the appropriate values for each item.
- 5 Press **Go** to exit Service Mode.

Setting the Cold Reset Default Paper Size

When replacing a Formatter PCA with a default paper size setting of A4, set `COLD RESET PAPER=` to A4.

- 1 Enter the Service Mode as previously described in this chapter.
- 2 Press **MENU** to access the Service Menu.
- 3 Press **ITEM** to step through the menu until `COLD RESET PAPER=LETTER*` is displayed.
- 4 Press **+** to toggle between Letter and A4 paper.
- 5 Press **SELECT** to activate your choice.
- 6 Press **GO** to exit Service Mode.
- 7 Perform a Cold Reset to activate new choice.

Testing the Mopier

Paper Path Test

You can test printer operation with the Paper Path Test. It will print 1, 10, 50, 100, or 500 (single or 2-sided) pages from any of the paper trays (or the Envelope Feeder) and deliver them to a previously specified output bin.

First, select `PAPER DESTINATION` and `2-SIDED` printing (if a duplexer is installed) in the Configuration Menu (table 3-10), and then run the Paper Path Test from the Information Menu (table 3-6).

Note

If feeding from Tray 1, the default output will always be the Face-up Bin.

- 1 Press `MENU`.
- 2 Press `(-)ITEM` twice.
- 3 Press `SELECT` and continue making your desired paper path test.
- 4 Press `SELECT` to execute the test.

Configuration Page

When you print a Configuration Page, the printer checks its internal controller and I/O interface, then prints a page showing the overall printer configuration (see figure 7-16 on page 590), and a Menu Map showing the current menu settings (see figure 7-15 on page 588). You can review these printouts to verify proper installation of installed accessories, options, and personalities.

- 1 Press `MENU` until `INFORMATION MENU` appears.
- 2 Press `ITEM` until `PRINT CONFIGURATION` appears.
- 3 Press `SELECT` to print the configuration pages.

For sample information pages, see “Information Pages” on page 587.

Using the HP Digital Copy 320 Front Panel

Install the Front Panel Overlay

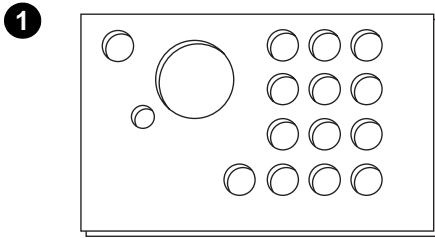

- 1 Choose the Front Panel overlay printed with your language.
- 2 Press the overlay in place on the HP Digital Copy 320 Front Panel until it clicks.
- 3 To remove the Front Panel overlay, pull it up and off.

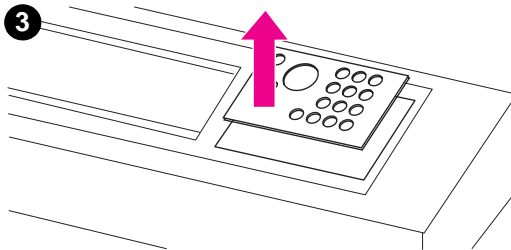
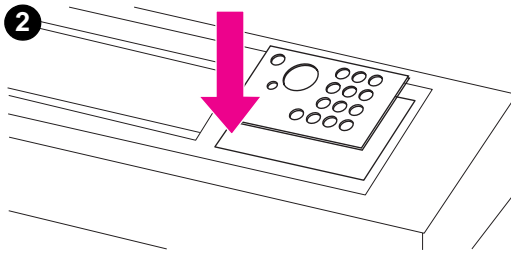

Note

The language that appears on the HP Digital Copy 320 display is customized through the language selected on the Mopier. If the Mopier language is set to a language other than the six offered by the HP Digital Copy 320 (English, French, Italian, German, Spanish, and Dutch), then the HP Digital Copy 320 will default to English. (See the Mopier online user guide for more information.)

HP Digital Copy 320 Front Panel

Front Panel Layout and Display Settings

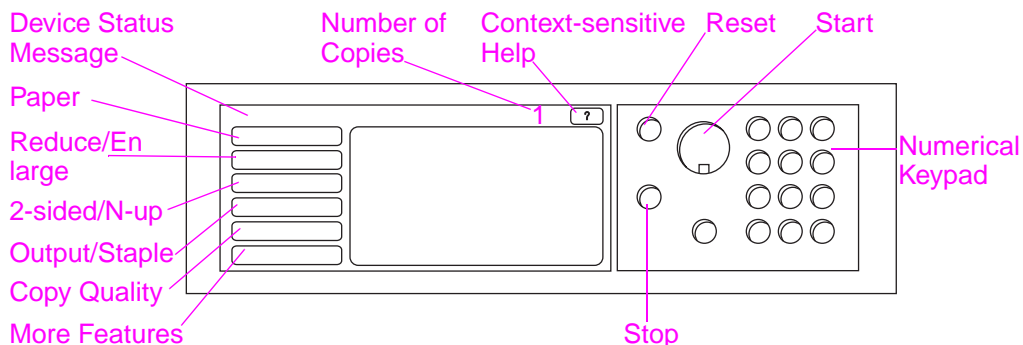

Figure 3-2 Front Panel Layout

Table 3-15. Status Bar

The Status Bar displays the current:

- "device status message"
- "number of copies selected"
- "context-sensitive help button" (available for certain features)

device status message	The READY TO COPY, COPYING, or ACCEPTING COPY JOBS message is displayed. ACCEPTING COPY JOBS indicates that the Mopier is busy. You can configure the next copy job when the Mopier is busy.
number of copies selected	The current number of copies selected for the copy job is displayed. This setting defaults to 1.
context-sensitive help button	This button remains present on the Front Panel display when available. When selected, help for the function appears.

Table 3-16. Menu Tabs

Menu Tabs allow access to any of the HP Digital Copy 320 settings. Each tab shows related job settings. Select **OK** or **EXIT** to make changes as you move from tab to tab. Press **OK** to exit the menu tabs and start a copy job. Press **EXIT** to return to the default display tab. You can also select **START** to begin a copy job before exiting the menu tabs.

Menu tabs

- "paper tab"
- "reduce/enlarge tab"
- "2-sided/N-up tab"
- "output/staple tab"
- "copy quality tab"
- "book copy tab"
- "job binding tab"
- "configuration tab"
- "about tab"

paper tab

Allows you to choose paper for the copy job based on size, tray, or type.

- **Size** - Shows the current size selected. When a selection is made, the Tray list will update automatically.
- **Tray** - Shows the current tray selected. If the selected paper size is currently installed in multiple trays, the Tray selection text will highlight **AUTOMATIC**. This indicates that the Mopier will make the tray selection based on its auto-selection criteria. If the selected paper size is located in only one tray, the location will be shown by the list text. When a selection is made, the Size and Type will update automatically.

Note

If you choose a paper type that is not already loaded in the Mopier, the Mopier will prompt you to load Tray 1 with the correct paper before the job is printed.

Table 3-16. Menu Tabs (continued)

reduce/enlarge tab

Allows you to enlarge or shrink the size of the document.

Allows you to choose the paper size for your original document and specify a different size for the copy. For example, copying from A4 to letter. You may also specify the output paper size and then choose a scaling percent to reduce or enlarge a region of the source document. You may choose to copy a fully bled page onto the printable region of the output paper.

You are presented with the following controls for selecting the desired paper scaling percent:

- **Reduce/Enlarge** - Shows input-to-output paper sizes. When a size is selected, the proper scaling percent for the currently selected input and output paper sizes is displayed.
 - **Percent** - Shows the current page scaling percent.
-

Table 3-16. Menu Tabs (continued)

reduce/enlarge tab
(continued)

- **Custom Media Reduction** - This setting allows you to switch between the standard/enlargement settings and the custom mode. This allows you to choose your original and copy document sizes independently.

When the Custom Media Reduction box is checked, you can select a paper size under the Original list for your original document and then select the paper size in the Copy list for the size you want to copy. The percent text box automatically calculates page scaling percent.

When the Custom Media Reduction box is unchecked, you may select from a list of standard reduction or enlargement settings, such as Letter (LTR) to Legal (LGL). Also, you may select the Manual setting in order to adjust the scaling percent by hand. When Manual is selected you may increase or decrease the scaling percent by one percent increments. You may reduce a document by up to 25 percent or enlarge a document by up to 200 percent. When you have chosen Manual, you may also choose the size of your original document. The copier will reduce that document by the percent you have selected.

- **Shrink Page to Printable Region** - This allows you to copy a fully bled page onto the printable region of the currently selected output paper size. There are limits to how far out to the edge of the page the Mopier can print. If you are copying a page that has printing all the way out to the edges (full bleed), then checking this box will cause the image to be reduced slightly so that the entire edge-to-edge image may print within the printable region of the output paper.
-

Table 3-16. Menu Tabs (continued)

2-sided/N-up tab

This tab has four controls for setting up the options and a preview image that graphically illustrates the current settings.

- **2-sided Copying** - Shows the currently selected 2-sided mode. Choose the two-sided mode you need. The preview image will update to display your choice.
- **Flip Pages Up** - This setting is active if the you choose to copy onto both sides of the output paper. By default, the pages of the two-sided binding are flipped to the left, like a book, when viewed from the backside of the job. When the setting is checked, the pages are bound, appearing flipped up when viewed from the backside of the job. The preview image will update to display your choice.
- **N-up Copying** - Shows the currently selected number of input pages to be printed on each output page. Choose the number of input pages needed to print on each output page. The preview image will update to display your choice.
- **Print Page Borders** - This setting is active when you select two or more pages for each sheet. When checked, page borders will print around each page image on the output page. The preview image will update to display your choice.

output/staple tab

- You can configure the output and stapling options using the two main controls on this tab.
 - **Output Bin** - Shows the currently selected output bin. Choose which bin the copy job will be delivered to. If the output bin is set to the stapling bin and a stapling option is selected, then changing the output bin to another location will turn off the stapling option.
 - **Stapling** - Allows you to choose stapling options. The number of options displayed will depend on the stapling device installed. If you select an option to have the output stapled, then the Output Bin setting will change to display that stapling can only take place in the staple bin.
-

Table 3-16. Menu Tabs (continued)

copy quality tab	<ul style="list-style-type: none">● Copy Mode - You may change the copy quality settings from this tab. There are three settings to choose from in Copy Mode: Photo - This mode is optimized for photo clarity. Text - This mode is optimized for text sharpness. This is the default mode.● Brightness - You may change the brightness setting from this tab. Press the left or right arrow to increase or decrease the brightness level as indicated by the slider. There are five settings for brightness.
book copy tab	<p>Allows you to make a copy of an open book with a single page of output for each page of the book. Align the spine of the book with the book markings on the flatbed paper guides.</p> <ul style="list-style-type: none">● Follow the prompts provided on the Front Panel when using this mode.● You can copy multiple pages from a book and bind them together as one job. See the "job binding tab" description for more information.
job binding tab	<p>Takes multiple copies from the flatbed and binds them together as one job. This allows the user to duplex, print n-up pages, and staple jobs from the flatbed.</p> <ul style="list-style-type: none">● Follow the prompts provided on the Front Panel when using this mode.
configuration tab	<p>Provides configuration settings for the HP Digital Copy 320. For example:</p> <ul style="list-style-type: none">● Allows you to turn on or off the audible key feedback.● Allows you to adjust the Front Panel display contrast.

Table 3-16. Menu Tabs (continued)

about tab

Used to find available help topics.

Displays:

- system version information.
 - current page counts for the flatbed and ADF.
 - number of pages until the next required service.
-

Table 3-17. Context-sensitive Help

Press the  to enter the HP Digital Copy 320 help system. Follow the prompts provided in the help system to find additional descriptions of certain features and functions.

Table 3-18. Default Configurations

If the HP Digital Copy 320 is idle and unattended for one minute, the HP Digital Copy 320 settings will return to the default configuration. Press the Reset key on the Front Panel to return all of the HP Digital Copy 320 settings to the default configuration.

The setting changes that you make will remain for one minute before they reset to a default setting. For example, if you walk up to the HP Digital Copy 320 and press the 5 key, the number of copies selected will be set to five. If you do not make any other setting changes and do not initiate a job by pressing the Start key within one minute, then the number of copies selected will automatically return to one.

After a copy job is completed, the current settings will not change until after another minute expires. This makes it possible to set up the HP Digital Copy 320 settings in a particular manner only once for a number of jobs.

Button/LED Functions

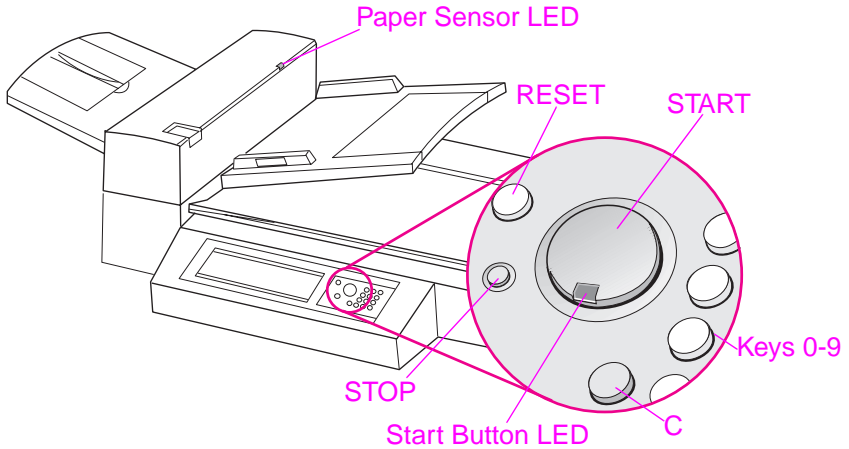

Figure 3-3 Button/LED Functions

Table 3-19. Functions of Buttons and LEDs

Name of the button or LED		Function
Button	0-9	Use to enter the number of copies you desire. May also be used periodically to enter a numerical value (for example, in service mode).
	RESET	Resets all of the copier settings to the default values.
	START	Begins a copy job or continues a copy job that has been interrupted because of an error.
	STOP	Stops a copy job.
	C	Clears the number of copies setting. (Does not clear the other copy module settings.)
LED	Paper Sensor LED	Illuminates when paper is loaded correctly in the ADF.
	Start Button LED	See “Start Button LED” on page 99 for a detailed description of this LED.

Start Button LED

Table 3-20. Start Button LED States

LED color	On	Flashing Slow	Flashing Fast
Green	The copy module is ready to make copies.	The copy module is in Power Save mode.	The copy module is making copies.
Amber	The copy module has a critical error. Turn the Mopier and copy module off, and then turn the Mopier and copy module on.	The copy module has an error and requires attention.	The copy module has an error that requires attention from your service provider.

Note When the copy module is in Power Save mode, the back light of the display panel will be turned off and the Start LED (green) will flash at a slow rate to indicate that the system is turned on. To bring the system out of Power Save mode, place paper in the ADF, press any key on the numerical keypad, or touch the touch screen.

HP Digital Copy 320 Settings

Table 3-21. Default Settings

Feature	Description	Default
Number of copies	1 to 999	1
Paper Source Select	Selection of paper tray	Auto-select (any tray)
	Selection by paper size	Letter/A4
		Plain
Collation	Collated	Collated
	Grouped (uncollated)	
	Stapled	
	Select output bin	
Reduce/Enlarge	25% to 200% in 1% increments	100%
	Support standard presets, such as Legal to Letter.	
Copy quality	text, photo	text
Duplex	1-1, 1-2, 2-1, 2-2	1-1
	If the Mopier does not have a duplexer installed, then 1-2 and 2-2 are not available.	
N-up	1-up, 2-up, 4-up	1-up
	2-up documents will be rotated.	

Table 3-21. Default Settings (continued)

Feature	Description	Default
Book copy	Copies an open book with a single page of output for each page of the book.	Not selected
Brightness	5 levels (2 lighter, normal, 2 darker)	Normal
Job binding	This allows the user to duplex, print n-up pages, and staple jobs from the flatbed.	Not selected

Loading documents into the ADF

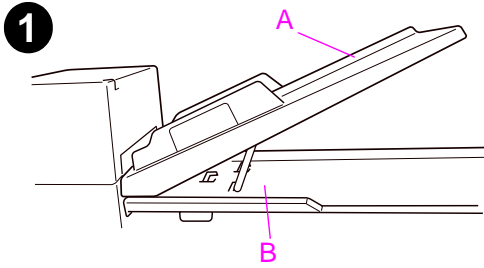

- 1 Pull up on the ADF input tray (A) and place the bar (B) in operating position.
- 2 Square up and insert originals face down into the input tray. Load to the line indicator on the paper guide.

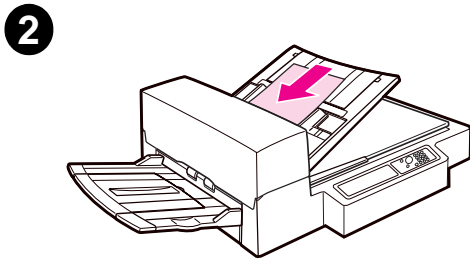

Note

The system will exit Power Save when you place the document into the ADF.

The LED will light up and a tone will sound when paper is loaded correctly.

Remove paper clips and staples.
Flatten the staple holes.

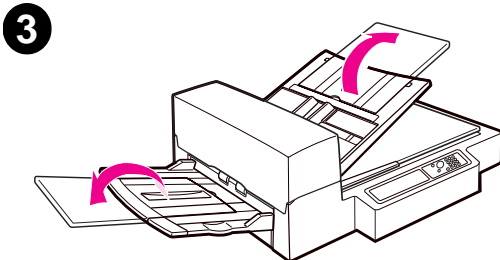

- 3 If the document size exceeds A4 or Letter size, extend the input tray and output bin by flipping out the extensions.

Continued on next page.

4

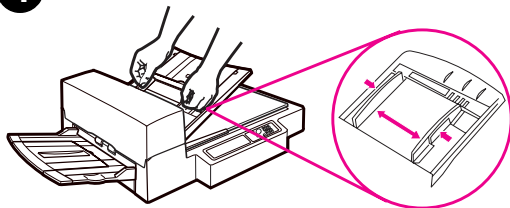

- 4 Set the guides so that there is a little amount of clearance between the side edges and the guides. Adjust the guides to the document size.

Note

Squeeze the guide lever to free the guides.
Load documents so that the thickness is less than 0.32 inches (8 mm).
Set the guides so that they touch the document sides.

5

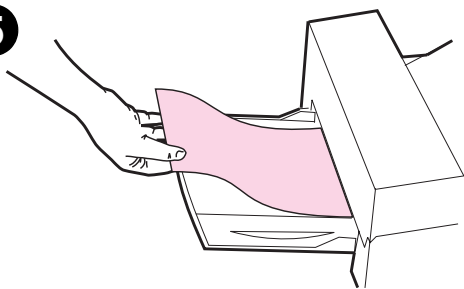

- 5 After a document is copied, remove the original from the copy module and the copy from the Mopier output bin.

Note

Letter and A4-size originals fed through the ADF will be rotated automatically to print correctly.

Loading documents onto the Flatbed

1

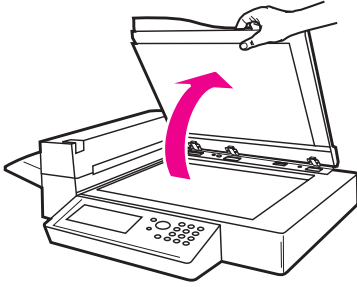

- 1 Open the document cover.
- 2 Place the document face down and align the top left with the reference mark. Carefully close the document cover and press **START**.

2

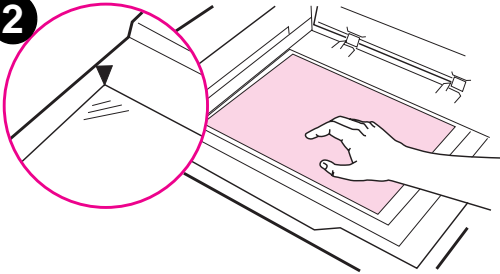

Copy Module Service Mode

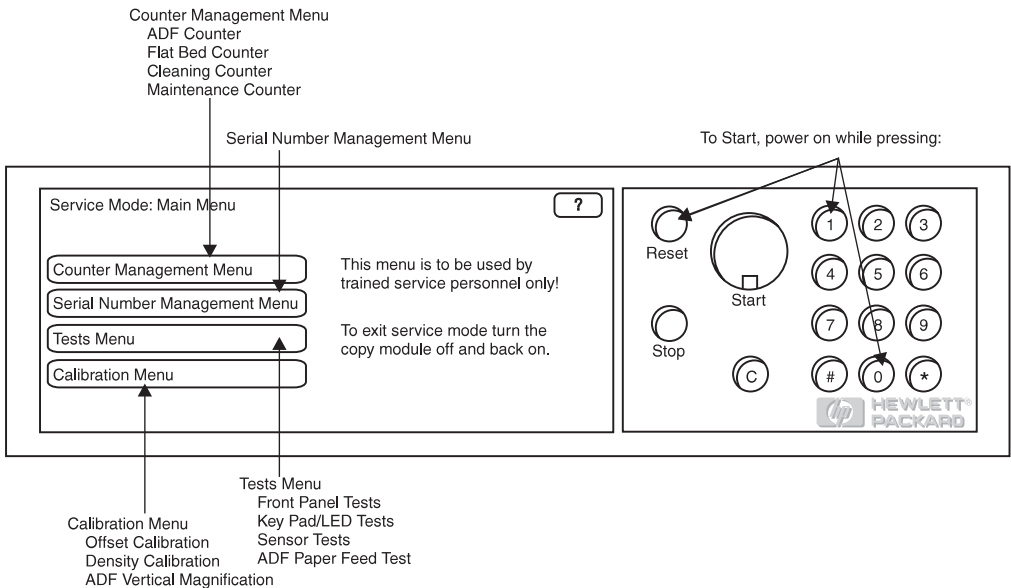

Figure 3-4 Copy Module Service Mode

To enter service mode, hold down the **RESET**, **0** and **1** keys while you turn on the power. The copy module skips its normal power up self-tests.

- Reset the ADF cleaning counter and maintenance counter to zero when you perform cleaning and maintenance procedures.
- In case of a failed EEPROM, reprogram the copy module's serial number from the Serial Number Management Menu.
- Use the Calibration Menu to recalibrate the copy module when you replace the following parts:
 - Lamps
 - Optics
 - ADF Assembly
 - Carrier Unit
 - Flatbed Cover Assembly
 - Control PCA with EEPROM

Note

The EEPROM stores all calibration settings. If you replace the Control PCA, be sure to retain the EEPROM from the bad Control PCA and install it in the replacement Control PCA.

- Test sensors, Front Panel and the ADF from the Tests Menu.

HP Resource Manager

Use the Custom Install option when you load the software to obtain the HP Resource Manager. Use the HP Resource Manager as shown in the figures below to redownload the copy module firmware.

Accessing the HP Resource Manager

HP Resource Manager is available for Windows 9x and Windows NT only.

- 1 From the **Start Menu**, click **Programs**.
- 2 Click **HP Mopier**.
- 3 Click **HP Resource Manager**. HP Resource Manager searches for installed printers.

Downloading Copy Module Firmware

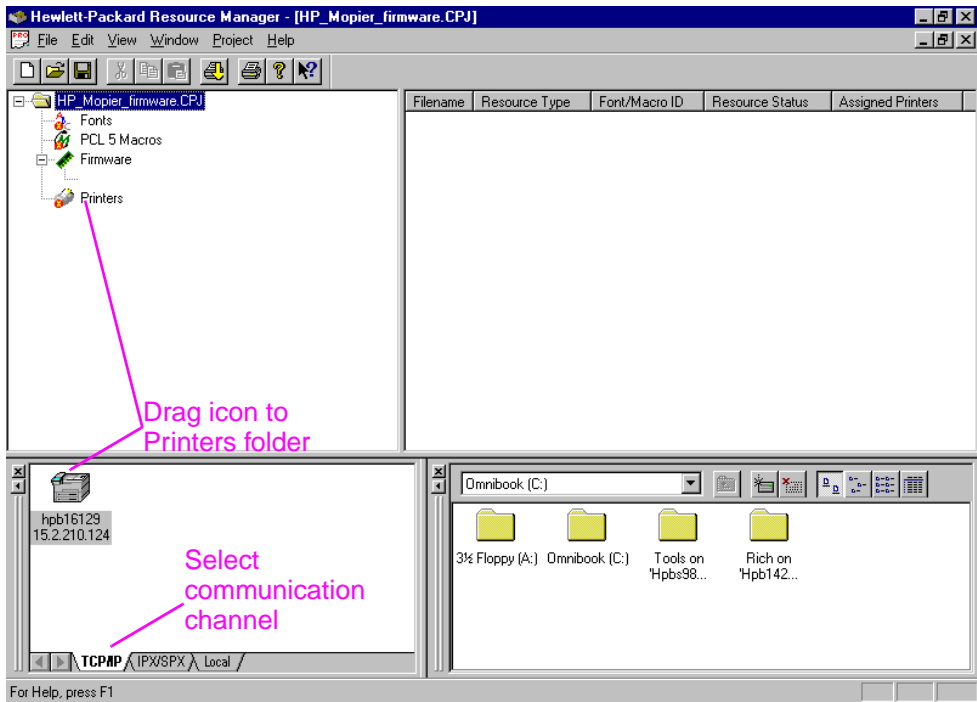

Figure 3-5 HP Resource Manager (1 of 2)

- 1 Select the preferred communication channel at the bottom of the screen: **TCP/IP**, **IPX/SPX**, or **Local**.
- 2 Drag the icons for the printers to be updated into the Printers folder. Multiple printers can be updated at the same time.

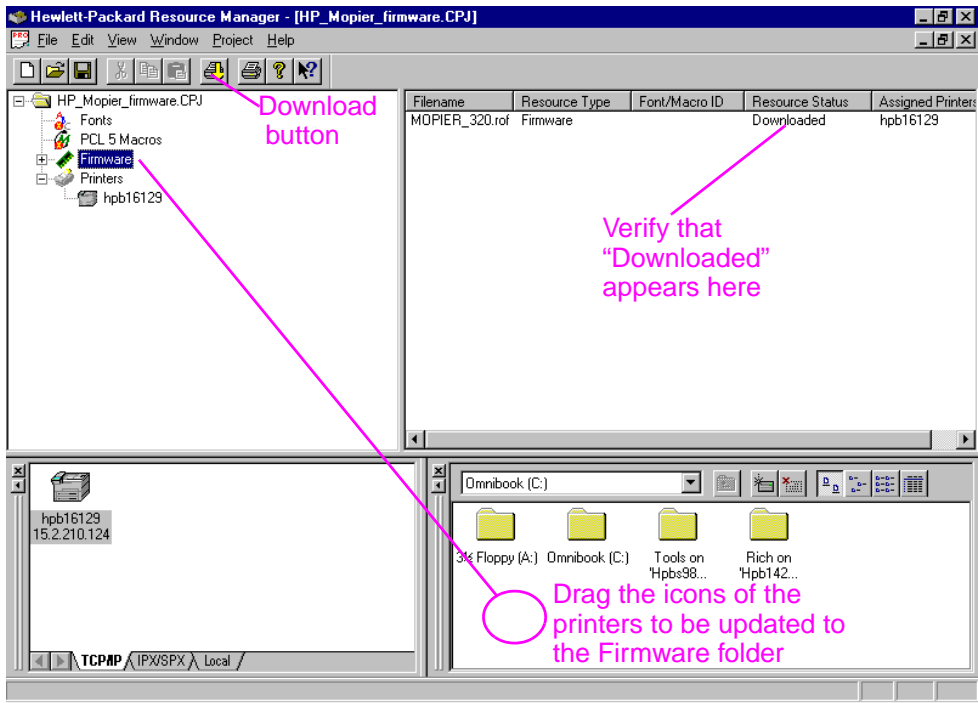

Figure 3-6 HP Resource Manager (2 of 2)

- 3 Obtain the new firmware file from www.hp.com. Browse to the newly downloaded firmware file from the lower right window. Drag the file icon from the lower right window to the Firmware folder.
- 4 The upper right window is updated to reflect the mopier's firmware status.
- 5 Click the Download button and wait for the operation to complete.
- 6 Verify that "Downloaded" appears as shown.
- 7 Power cycle the Mopier and copy module.

4 Maintenance and Adjustments

Chapter Contents

HP Mopier 320

Cleaning the Mopier and Accessories - - - - -	112
Preventive Maintenance - - - - -	115
Tray Adjustment Procedure- - - - -	116
2000-sheet Input Tray Adjustment Procedure - - - - -	118

HP Digital Copy 320

Cleaning the HP Digital Copy 320 - - - - -	120
Cleaning ADF and Glass - - - - -	121
Complete Optics Cleaning - - - - -	124
Maintaining the HP Digital Copy 320 - - - - -	126
Calibrating the HP Digital Copy 320 - - - - -	126

Cleaning the Mopier and Accessories

To maintain print quality and paper performance, thoroughly clean the printer and the paper handling devices:

- Every time you change the toner cartridge.
- After printing approximately 20,000 images.
- Whenever print quality problems occur.

Clean the outside surfaces with a lightly dampened cloth. Clean the inside with only a dry, lint-free cloth. Use the guidelines listed in table 4-1. Observe the warnings and cautions below.

WARNING!

Before you begin these steps, turn the printer off and unplug all power cords to avoid shock hazard.

Be careful when cleaning around the Fusing Assembly area. It may be HOT.

CAUTION

To avoid permanent damage to the toner cartridge, do not use ammonia-based cleaners on or around the printer.

Do not touch the transfer roller with your fingers. This can cause print quality problems.

Cleaning the Mopier

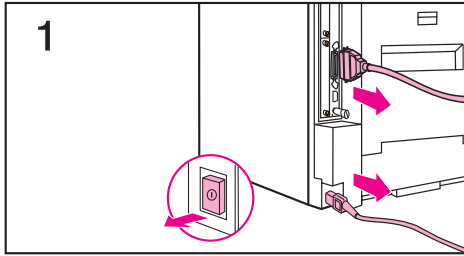

- 1 Before you begin these steps, turn the printer off and unplug all cords.
- 2 Open the top cover of the printer and remove the toner cartridge.

WARNING!

Avoid touching the adjacent fusing area. It may be HOT.

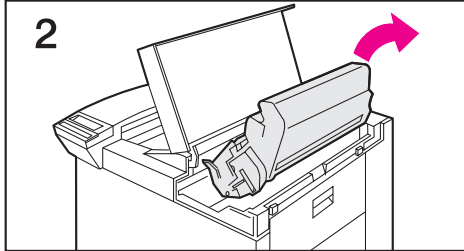

CAUTION

Do not touch the transfer roller (A). Oils from your hands can contaminate the roller and reduce print quality. If toner gets on your clothes, wipe it off with a dry cloth and wash your clothes in *cold* water. Hot water sets toner into fabric.

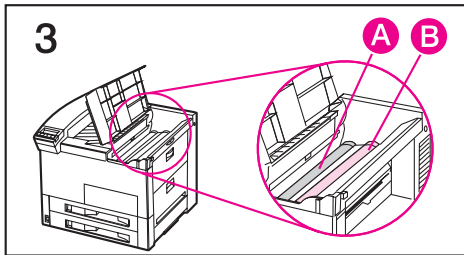

- 3 With a *dry* lint-free cloth, wipe any residue from the paper path area, the registration roller (B), and the toner cartridge cavity. Use the brush supplied with the printer to remove residue from tight areas.
- 4 Replace the toner cartridge, close the printer, reconnect all cables, and turn the printer on.

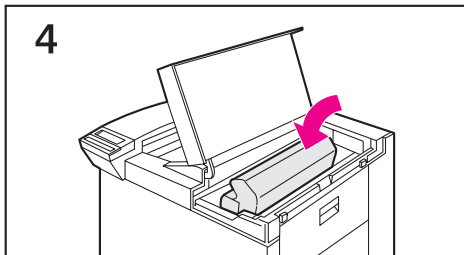

Table 4-1. Cleaning the Printer

Component	Cleaning Method/Notes
Outside Covers	Use a water-dampened cloth. Do not use solvents or ammonia-based cleaners.
Inside General	Use a dry, lint free cloth. Remove all dust, spilled toner, and paper particles.
Paper Pickup, Feed, and Separation Rollers	Use a water-dampened lint-free cloth.
Separation Pad	Use a dry lint-free cloth.
Registration Roller	Use a dry lint-free cloth.
Transfer Roller	Use a dry, lint-free cloth. DO NOT TOUCH the transfer roller with your fingers.
Fusing Assembly	Use a water-dampened lint-free cloth.

Cleaning Spilled Toner

Defective toner cartridges can develop leaks. Also, after a paper jam has occurred, there may be some toner remaining on the rollers and guides inside the printer. The images that print immediately after the jam may pick up this toner.

Clean spilled toner with a cloth slightly dampened in cold water. Do not touch the Transfer Roller with the damp cloth or with your fingers. Do not use a vacuum cleaner unless it is equipped with a micro-fine particle filter.

Note

If toner gets on your clothing, use cold water to remove it. Hot water sets toner stains into fabric.

Preventive Maintenance

The user-conducted preventive maintenance cycle for this printer is every 350,000 images. The part numbers for the preventive maintenance kits are C3914A for the 100V printers, and C3915A for the 220V printers. The kits contain the following replacement parts: one Fusing Assembly, one Transfer Roller Assembly, and eight Feed/Separation Rollers [two each for Trays 2, 3, the 2000-sheet Input Tray (Tray 4), and the 2 x 500-sheet Input Tray (Trays 4 and 5)]. See Chapter 6 of this manual, and the instructions included in the kits for detailed replacement procedures.

The control panel message, `PERFORM PRINTER MAINTENANCE`, indicates that the 350,000 image maintenance is due. Upon completion of the maintenance procedures, go to the control panel Configuration Menu and set the `SERVICE MESSAGE=` to `OFF`.

The default (350,000) maintenance message interval can be set to lesser values if needed (50K, 150K, 250K), for printers requiring more frequent maintenance. This feature is provided for customers using heavy, rough, or generally out-of-specification media that prematurely wears out the maintenance parts.

Tray Adjustment Procedure

This procedure applies to Trays 2 and 3 (the standard paper trays in the printer) and Trays 4 and 5 in the 2 x 500-sheet Input Tray. To adjust the 2000-sheet Input Tray see “2000-sheet Input Tray Adjustment Procedure” on page 118.

The paper trays are mechanically aligned to the printer chassis at the factory. Perform this procedure **ONLY** if a paper tray has been replaced with a tray other than the original factory installed tray, or if the top margin of the image area is off-center more than 0.5 mm (0.02 inch). The adjustment procedure is identical for Trays 2, 3, 4, and 5 from the 2 x 500-sheet Input Tray.

Note

Before performing this procedure, check that the margins in your software application are properly set.

- 1 Load the paper tray being tested with letter or A4 size paper.
- 2 Perform a 1-sheet Paper Path Test from that tray (see Paper Path Test under Test Menu in Chapter 3).
- 3 See figure 4-1 and compare distance A to distance B.

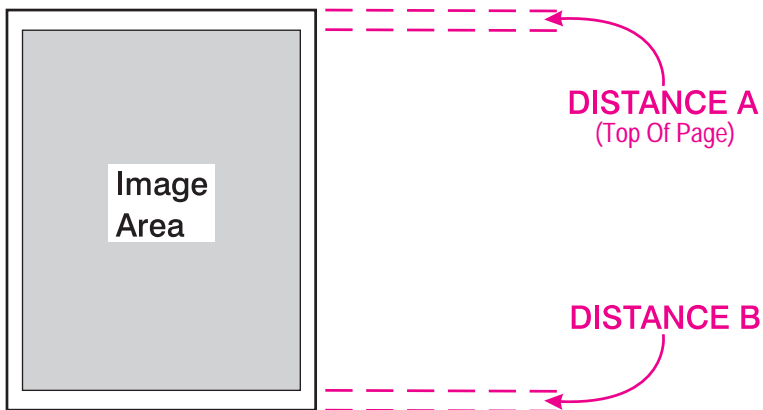

Figure 4-1 Image Area Margins

Note

See figure 4-2. Each adjustment notch changes the physical position of the tray by 0.5 mm (0.02 inch). Moving the lever counter-clockwise moves the tray inward and increases distance A. Moving the lever clockwise moves the tray outward and decreases distance A.

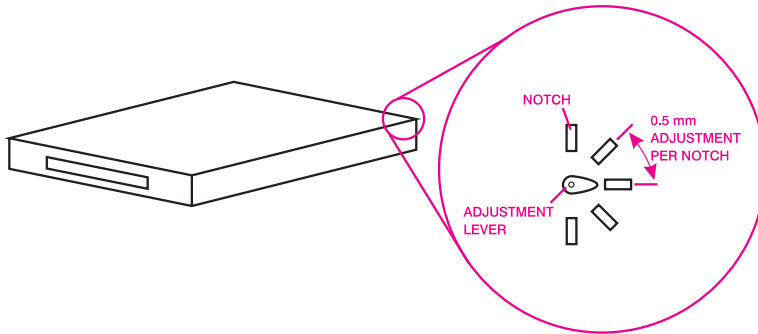

Figure 4-2 Tray Position Adjustment

- 1 If distance A is greater than distance B by more than 0.5 mm (0.02 inch), move the adjustment lever clockwise one notch.
- 2 If distance A is less than distance B by more than 0.5 mm (0.02 inch), move the adjustment lever counter-clockwise one notch.
- 3 After adjusting:
 - Reinstall the tray.
 - Re-run the Paper Path Test.
 - Recheck the measurements.
 - Re-adjust as necessary.

2000-sheet Input Tray Adjustment Procedure

This procedure applies to the 2000-sheet Input Tray. To adjust Trays 2 and 3 (the standard paper trays in the printer) and the 2 x 500-sheet Input Tray (Trays 4 and 5) see page 116.

In some cases, the registration from the 2000-sheet Input Tray causes print to start too close to the edge of the paper. This situation is not a typical occurrence. In most cases the 2000-sheet Input Tray offset is fine. Although this may or may not be within specification, it is unacceptable to some users. Perform the following adjustment procedure to correct the situation.

- 1 With the 2000-sheet Input Tray stand-alone, remove left, right and rear covers from the tray.
- 2 Remove the vertical transfer unit.
- 3 Open the 2000-sheet Input Tray paper tray.
- 4 Loosen both screws that support the paper tray locking bracket on the right side of the 2000-sheet Input Tray (see figure 4-3).

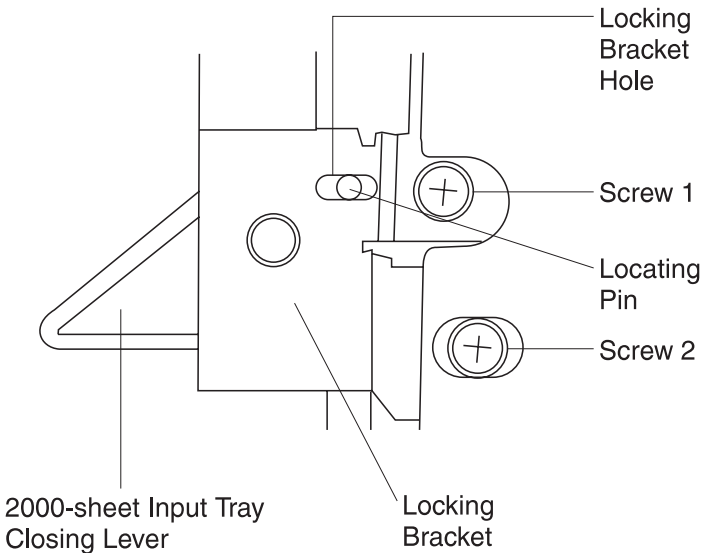

Figure 4-3 Tray 4 Position Adjustment

- 5 Locate the bracket hole and pin at the middle (right side) (see figure 4-3).
- 6 Slide the bracket so that the locating pin is positioned at the middle of the bracket hole.
- 7 Tighten both screws.
- 8 Loosen both screws that support the paper tray locking bracket on the left side of the 2000-sheet Input Tray.
- 9 Locate the bracket hole and pin at the middle (left side). Slide the bracket so the locating pin is positioned at the middle of the bracket hole.
- 10 Tighten both screws.
- 11 Reassemble the vertical transfer unit.
- 12 Make sure all the cables (vertical transfer unit and paper deck drive assembly) are reconnected.
- 13 Reinstall left, right, and rear covers to the tray.

Note

The locating pin position at the middle could still be unacceptable for some customers' applications. If so, repeat the procedure by moving the locating pin further back and testing the margin obtained.

Cleaning the HP Digital Copy 320

Clean the ADF Assembly, including the Rollers and Separation Pad, every 6,000 pages, or more frequently with certain paper types. To check the “ADF Scans Since Last Cleaning” counter, print a Configuration Page from the Mopier Information Menu. You must reset the cleaning counter in the Mopier’s service mode after you clean the copy module (see page 87).

Symptoms indicating that it is time to clean the copy module include increasing mispicks and an optical failure.

Materials

- Dry, lint-free cloth
- Isopropyl alcohol (any concentration, including denatured alcohol)
- Vacuum (see below)
- Blow brush
- Glass cleaner (for flatbed glass only)
- Terrace Oil 46 (light weight oil)
- Alvania Grease No. 2 (white or silicone grease)

CAUTION

Do not use organic solvents such as thinner.

Never use glass cleaner on any part of the copy module except the flatbed glass.

Be sure no liquid enters the copy module from the edges of the Glass Plate Assembly. (See page 490.)

Vacuum Specifications

Use the same type of vacuum used for printer maintenance. Be sure to use a vacuum with adequate filtration so that microfine toner is not released into the air. Paper dust and unfused toner particles can accumulate in the ADF and on the Carrier Unit. The type of narrow attachments that are used with printer and copier machine vacuums are particularly useful for cleaning.

CAUTION

When using the vacuum be careful not to damage paper sensors. Never use the vacuum for the Carrier Unit or Optical Unit. These should be hand cleaned only.

Cleaning ADF and Glass

A quick clean takes approximately 15 minutes and should be performed every 6,000 pages.

Cleaning the Document Cover, Document Holder, and Flatbed Glass

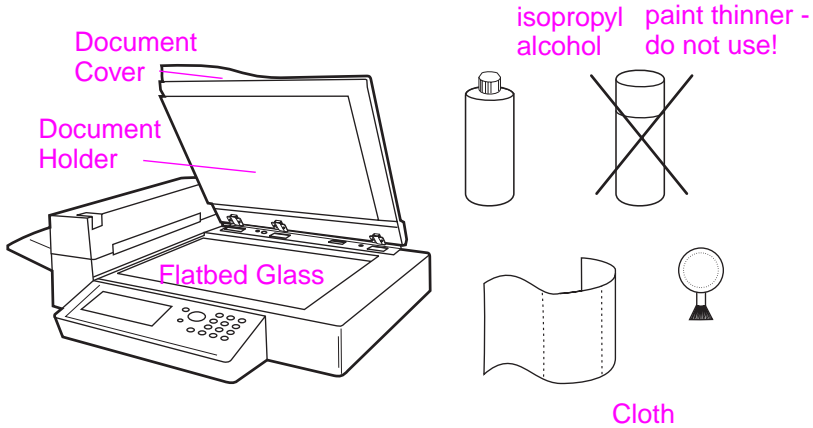

Figure 4-4

Cleaning the Document Cover, Document Holder, and Flatbed Glass

Use a cloth that is either dry or dampened with a small amount of the appropriate cleaning material listed in Table 4-2 below to remove dirt from the Document Cover, Document Holder, and flatbed glass.

Table 4-2. Cleaning the Document Cover, Document Holder, and Flatbed Glass

Part	Cleaning Materials
Document Cover	non-abrasive, neutral detergent or alcohol
Document Holder	
Flatbed Glass	alcohol or glass cleaner DO NOT USE DETERGENT

Cleaning the ADF

- 1 Unplug the copy module.
- 2 Press the latch and lift open the ADF.

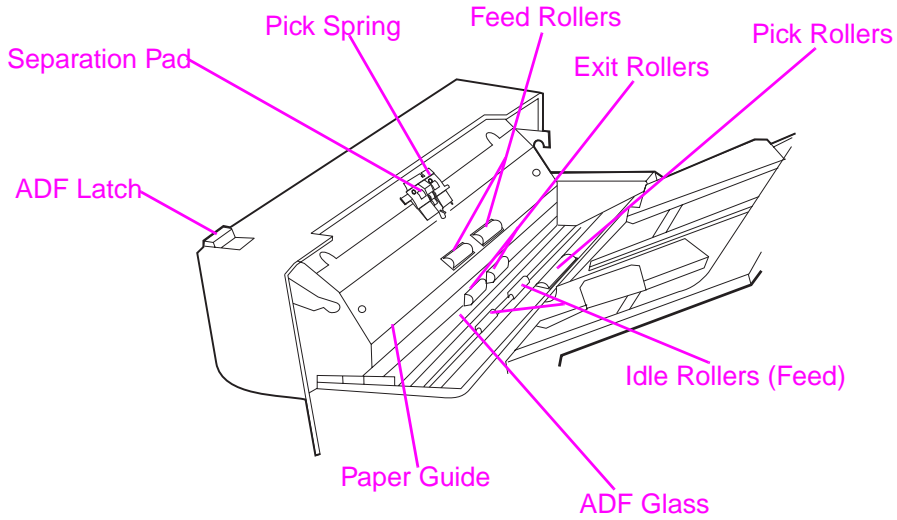

Figure 4-5 Parts of the ADF

Table 4-3. Cleaning the ADF

Part	Cleaning method	Problem with dirty or worn part
Separation Pad	Using a cloth with isopropyl alcohol, wipe the Separation Pad in a downward direction. Be careful not to hook the Pick Springs.	Double-feeds
ADF Glass	Wipe the glass lightly with a cloth and isopropyl alcohol or glass cleaner to remove any paper dust or toner.	Vertical streaking when you scan from the ADF

Table 4-3. Cleaning the ADF (continued)

Part	Cleaning method	Problem with dirty or worn part
Pick Rollers	Remove the Pick Rollers. Using a cloth dampened with isopropyl alcohol, firmly and thoroughly wipe each Pick Roller in a horizontal direction, from end to end to remove dirt. Do not touch the rubber part of the rollers. Skin oils can damage the rollers.	Misfeeds, paper slippage, and jams
Feed, Exit, and Idler Rollers	Using a cloth with isopropyl alcohol, wipe the rollers in a horizontal direction, making sure to remove any built-up toner or ink. Make sure the rollers are dry before scanning.	Paper jams
Paper Guide	Gently wipe the Paper Guide area with a soft cloth.	Vertical streaking when copying from the ADF

Complete Optics Cleaning

An optics clean takes approximately 30 minutes and should be performed every 12,000 pages.

Cleaning the ADF Lamp and Mirrors

CAUTION

Use a lint free cloth with isopropyl alcohol to clean the Lamp and to clean fingerprints, toner, or paper dust from the mirror. Be careful not to scratch the mirror. Do not use glass cleaner.

- 1 Open the ADF.
- 2 Remove the ADF Latch (page 451) and ADF Cover (page 452).
- 3 Remove the ADF Unit and ADF Lamp (pages 487 to 479).
- 4 Clean the mirrors with a blow brush. See the Caution above.
- 5 Clean the Lamp with a dry or alcohol-dampened, lint-free cloth. Do not touch the Lamp with your fingers.
- 6 Replace the Lamp, ADF Unit, ADF Cover, and ADF Latch Cap.

Lubricating the ADF Gears

If necessary, place an even coating of Alvania Grease No. 2 (white or silicone grease) on the teeth of the ADF Gears as needed.

Cleaning the Carrier Unit and Mechanical Assemblies

- 1 Remove the skins (starting on page 445) and the Glass Plate Assembly (page 490).
- 2 Clean any dirt from the back of the Glass Plate Assembly, especially under the ADF Unit and the White Reference Strip.
- 3 Vacuum any dirt from the inside of the Mechanical Frame.
- 4 Remove the Lamp from the Carrier Unit (page 494).
- 5 Remove any dirt from the Carrier Unit Mirrors with a blow brush.

CAUTION

Use a lint free cloth with isopropyl alcohol to clean fingerprints, toner, or paper dust from the mirror. Be careful not to scratch the mirror. Do not use glass cleaner.

- 6 If the Carrier Unit Shaft is dirty, wipe it off with a cloth, then relubricate it (see below). Otherwise, be careful not to remove the lubricant.

Lubricating the Carrier Unit Shaft

If necessary, or if the Carrier Unit shaft has been cleaned, place an even coating of Terrace Oil 46 (light weight oil) on the Carrier Unit Shaft as needed (for example, if paper dust or other material interferes with movement of the Carrier Unit, or if you have cleaned the shaft). See page 498.

Lubricating the Top of the Carrier Guide Rail

If necessary, or if the Carrier Guide Rail has been cleaned, place an even coating of Alvania Grease No. 2 (white or silicone grease) on the top of the Carrier Guide Rail as needed.

Lubricating the Flatbed Motor Gears

If necessary, place an even coating of Alvania Grease No. 2 (white or silicone grease) on the teeth of the Flatbed Motor Gears as needed.

Cleaning the Front Panel

Use a dry cloth to clean the Front Panel Display.

Maintaining the HP Digital Copy 320

The Separation Pad and Pick Rollers must be replaced every 60,000 pages through the ADF. To check the “ADF Scans Since Last Maintenance” counter, print a Configuration Page from the Mopier’s Information Menu. You must reset the maintenance counter in service mode after you replace the maintenance parts (see page 87). For removal and replacement procedures, see “Copy Module Maintenance Parts” on page 440. The procedures take approximately 15 minutes.

Symptoms that indicate it is time to replace the maintenance parts include increasing mispicks and visible wear or polish on the surface of the Separation Pad or Pick Rollers.

Note

If highly abrasive papers or papers high in calcium carbonate content are used, replacement intervals may be shorter.

HP Digital Copy 320 Maintenance Parts

- 2 Pick Rollers PA03002-C120FJ
- 1 Separation Pad PA03002-C122FJ

Calibrating the HP Digital Copy 320

Types of Calibration

- Automatic offset adjustment (Flatbed, ADF front, and ADF back)
- Density adjustment (do this when Lamps or the Optical Unit are replaced)
- ADF vertical magnification (only do this when you replace the ADF Assembly)

Note

The value of vertical magnification is unique to every ADF Assembly and is noted on a page included with the replacement ADF Assembly.

When to Calibrate

Perform calibration after any of the following tasks:

- Removing or replacing any of the Lamps or optics
- Replacing the ADF Assembly
- Replacing the Carrier Unit
- Replacing the Flatbed Cover Assembly
- Replacing the Control PCA with EEPROM

Calibration Target

Obtain the Calibration Target Kit from HP (part number PA03002-C261FJ)

or

Blacken a .4 inch (10mm) border around a standard A3 size sheet of white paper to create an offset target. A sample offset target is shown in figure 4-6.

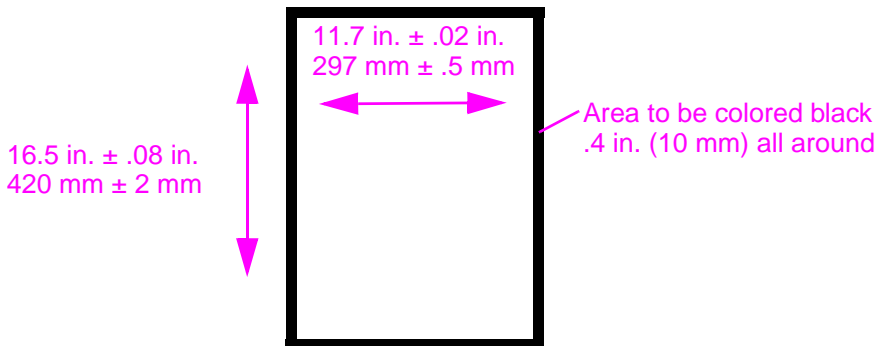

Figure 4-6 Creating an Offset Target

Entering the Calibration Menu in Service Mode

- 1 Start the copy module in service mode (hold down **RESET**, **0** and **1** keys while you turn on the power).
- 2 Select the calibration menu.

How to Perform an Offset Adjustment Calibration

- 1 Obtain or create a calibration target (page 127) and enter the Calibration Menu in service mode (page 127).
- 2 Select the appropriate offset calibration you wish to perform (flatbed, ADF front or ADF back).
- 3 Load the target and follow the prompts on the front panel. Changes will be saved automatically when the adjustment is complete.

How to Perform a Density Calibration Adjustment

- 1 Obtain a calibration target (part number PA03002-C261FJ) and enter the Calibration Menu in service mode (page 127).
- 2 Select Density Adjustment.
- 3 Load the target and follow the prompts on the front panel. Changes will be saved automatically when the adjustment is complete.

How to Perform an ADF Vertical Magnification Adjustment

- 1 Locate the page that shipped with the replacement ADF unit.
- 2 Enter the Calibration Menu in service mode (page 127).
- 3 Select ADF Vertical Magnification.
- 4 Enter the hexadecimal number from the page that shipped with the replacement ADF unit.

5 Functional Overview

Chapter contents

HP Mopier 320

Printer Functional Block Diagram - - - - -	130
Power Distribution System - - - - -	131
Formatter System - - - - -	134
DC Controller System - - - - -	137
Image Formation System- - - - -	139
Paper Paths and Components - - - - -	150
Paper Jam Detection - - - - -	182
Printer Timing - - - - -	182
IEEE 1284 Parallel Cable Information- - - - -	184

HP Digital Copy 320

Copy Module Functional Overview - - - - -	185
Power Up Process - - - - -	189
ADF Simplex Operation - - - - -	193
ADF Duplex Operation - - - - -	194
Flatbed Operation - - - - -	194
Image Path - - - - -	196
Communication to the Mopier - - - - -	198

Printer Functional Block Diagram

Figure 5-1 is a functional block diagram of the printer showing the basic paths for signal, control, and media.

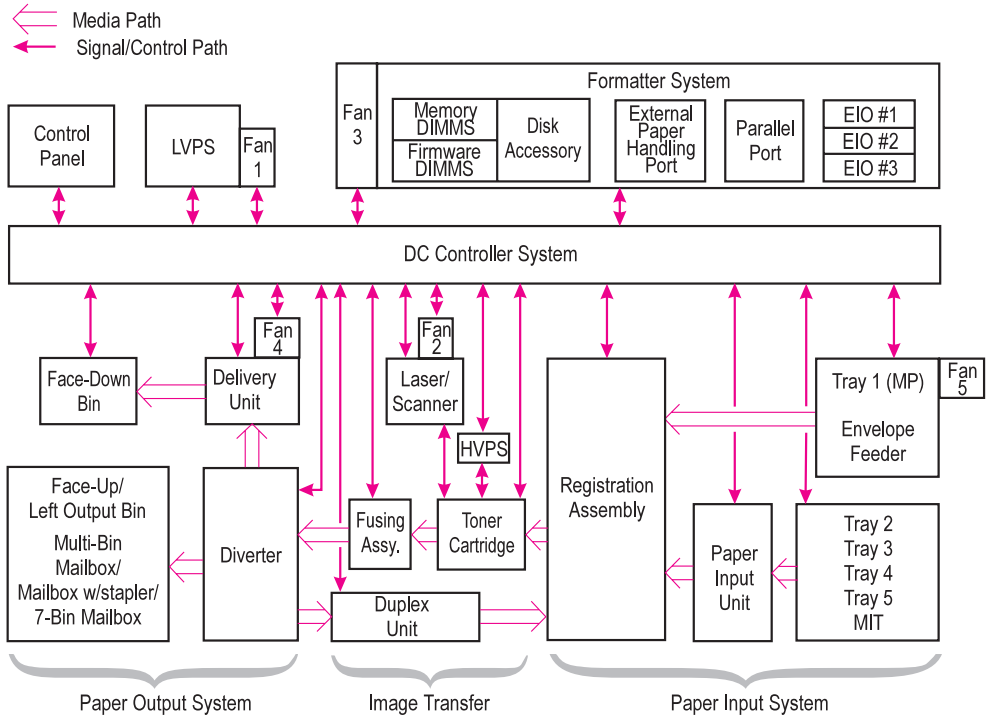

Figure 5-1 Printer Functional Block Diagram

Power Distribution System

The AC and DC power supply circuits are contained in the Low Voltage Power Supply (LVPS). The high voltages required for image formation are generated by the High Voltage Power Supply (HVPS). The LVPS and Distribution System is illustrated in figure 5-2. See the Reference Diagrams at the end of Chapter 7 for more details.

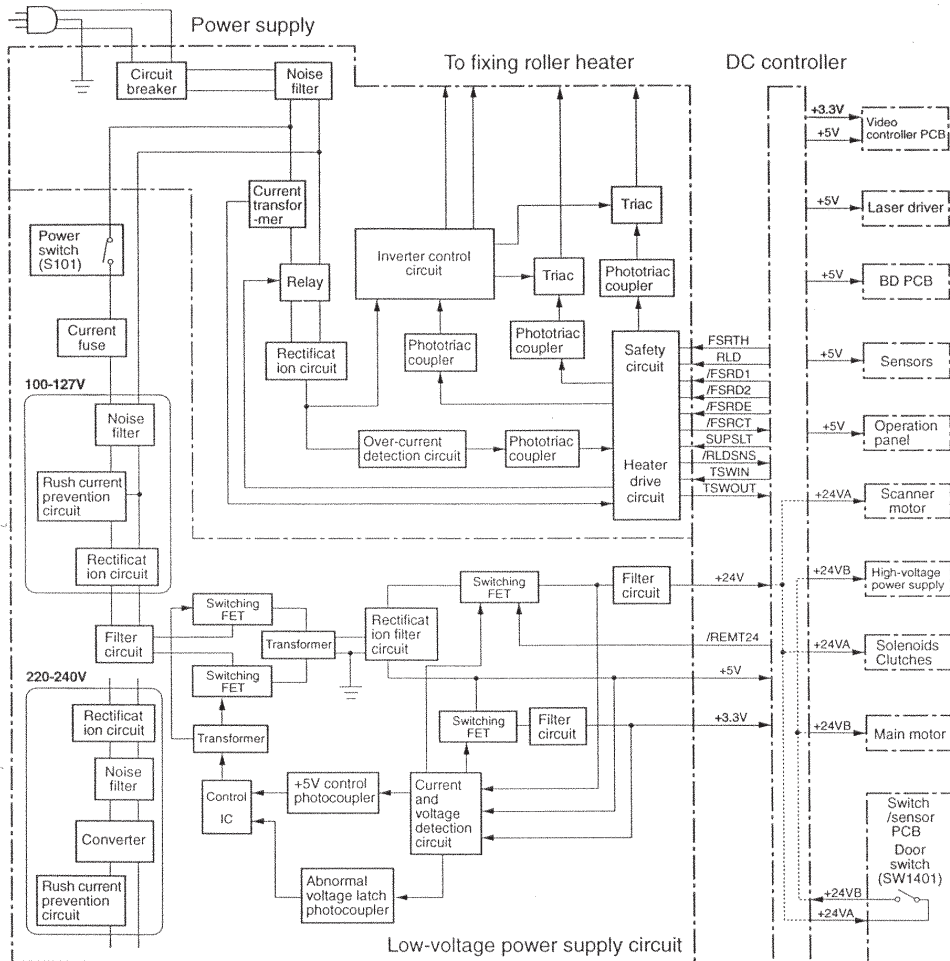

Figure 5-2 Low Voltage Power Distribution System

AC Power Distribution

The AC power circuitry supplies AC voltage whenever the power cord is connected, and the power switch is on. A toner cartridge must be installed and the top access door must be closed before AC voltage is supplied to the DC power circuits or the Fusing Assembly.

Overcurrent/Overvoltage Protection

There are two overcurrent/overvoltage devices in this printer:

- The resettable circuit breaker (CB101) shuts off AC input power to the LVPS in case of an AC overcurrent condition. To reset, remove the LVPS and press in the circuit breaker button (figure 5-3, callout 1).
- Fuse 101 interrupts AC input power to the +24V DC and +5V DC power circuits.

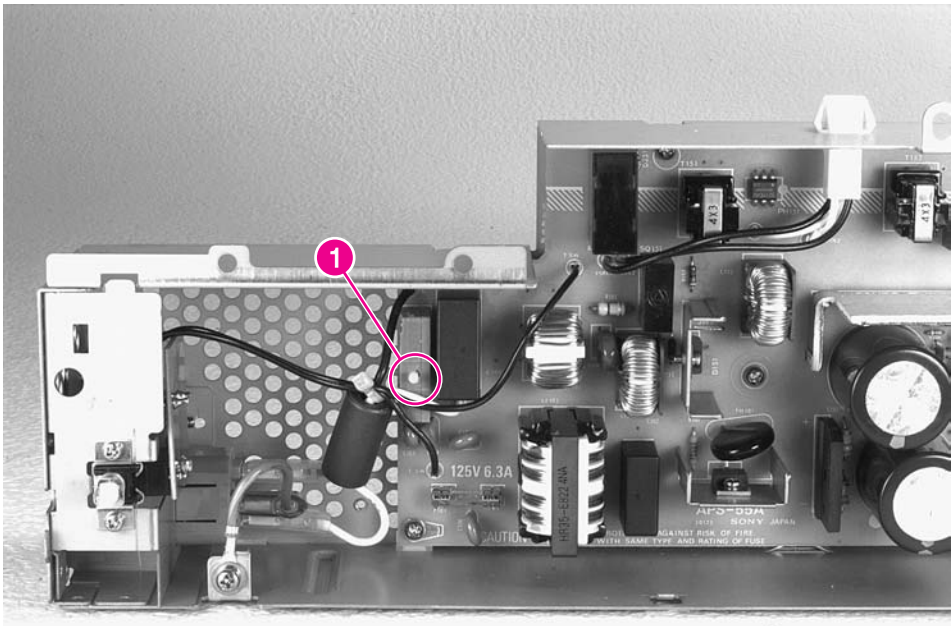

Figure 5-3 Low Voltage Power Supply

High Voltage Power Distribution

The High Voltage Power Supply (HVPS, see figure 5-4) applies a DC-biased AC voltage to the primary charging roller and the developing roller, and a programmed DC voltage (depending upon the phase of the printing process) to the Transfer Roller. See the General Timing Diagram (figure 5-29 on page 183) for HVPS timing information.

Toner Cartridge Detection

A toner level detector inside the toner cartridge is connected to the HVPS when the toner cartridge is installed. If the toner level drops below a predefined level, the `TONER LOW` message will appear on the display panel. If the toner cartridge is missing, `INSTALL TONER CARTRIDGE` will be displayed.

Print Density Adjustment

The high voltage power supply also controls the image density by varying the voltages applied to the developing cylinder in the toner cartridge. These voltages determine the amount of toner applied to the photosensitive drum. Print density is adjusted from the control panel (Print Quality Menu) or from the driver software.

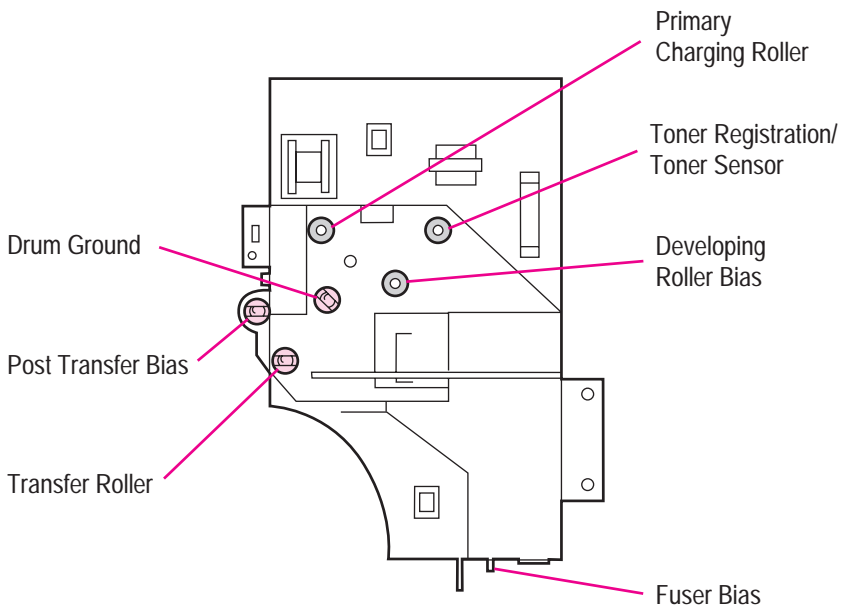

Figure 5-4 High Voltage Power Supply Contacts

Formatter System

The Formatter PCA is responsible for the following:

- Controlling the PowerSave mode.
- Receiving and processing print data from the various printer interfaces.
- Monitoring Control Panel inputs and relaying printer status information (through the Control Panel and the bidirectional I/O).
- Developing and coordinating data placement and timing with the print engine.
- Storing font information.
- Communicating with the host computer through the bidirectional Interface.

The Formatter PCA receives a print job from the bidirectional parallel port (IEEE 1284) and separates it into image information and instructions which control the printing process. The DC Controller synchronizes the Image Formation System with the Paper Input and Output Systems, and then signals the Formatter to send the print image data. The Formatter sends the print image data (dots) in the form of a VIDEO signal to start the printing process.

The Formatter PCA also provides the electrical interface and mounting locations for three EIO cards, additional memory DIMMs, the Disk Accessory, the 8-bin Mailbox/5-bin Mailbox with Stapler, the 7-bin Tabletop Mailbox, and the 2 x 500-sheet Input Tray (Trays 4 and 5).

PowerSave

This user-adjustable feature (Configuration Menu) conserves power by shutting down the fuser and exhaust fans after the printer has been idle for 15 minutes; 30 minutes; 1, 2, or 3 hours. The printer retains all printer settings, downloaded fonts, and macros while in PowerSave mode. The default setting is PowerSave on, with a 1-hour idle time. (PowerSave can also be turned off from the control panel.)

The printer exits PowerSave mode and enters the warm-up cycle when any of the following occurs:

- A print job, valid data, or a PML or PJJL command is received at the parallel port or an EIO card.
- A Control Panel key is pressed.
- Any printer door (except the front access door) is opened and then closed.

- A paper tray is opened and then closed.
- The Engine Test microswitch is pressed.

Note

Printer error messages override the PowerSave message. The printer will enter PowerSave mode at the appropriate time, but the error message will continue to be displayed.

Resolution Enhancement (REt)

The Formatter PCA contains circuitry for Resolution Enhancement technology (REt), which modifies the standard video dot data on its way to the DC Controller to produce “smoothed” black-to-white boundaries. REt is user-controllable (on or off) from the control panel, or from some software applications. The default setting is on.

Note

REt settings sent from software applications or printer drivers override the control panel settings.

EconoMode

The EconoMode setting uses less toner than the normal printing mode by reducing the dot density. EconoMode, which is a draft-quality printing mode, is user selectable via the control panel (Print Quality Menu) and some software applications. The default setting is off.

Note

EconoMode does not affect print speed, memory usage, nor extend toner cartridge life.

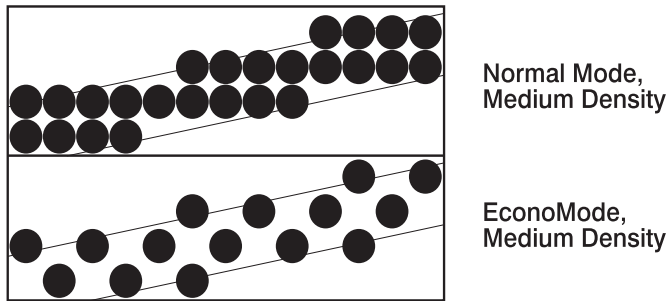

Figure 5-5 Normal Mode vs EconoMode

DC Controller System

The following systems and functions are controlled by the DC Controller PCA:

- DC Power Distribution (+3.3V DC, +5V DC, +24V DC)
- Laser and Scanner Drive
- Paper Motion Monitoring and Control (photosensors and flags)
- Clutches (registration, tray pickup, and Tray 1 feed)
- Engine Test
- Motors (Main Drive, Scanner, and Fans)

Figure 5-2 on page 131 shows the Low Voltage Power Supply and Distribution System. See the wiring diagrams at the end of Chapter 7 for detailed listings of the DC Controller inputs and outputs.

Laser and Scanner Drive

Based on information received from the Formatter, the DC Controller sends signals to the Laser/Scanner Assembly to modulate the laser diode on and off and to drive the Laser/Scanner motor. See “Image Formation System” later in this chapter for more information.

Paper Motion Monitoring and Control

The DC Controller PCA controls paper motion by continuously monitoring the various paper sensors and coordinating paper movement with the other print processes.

Clutches

The DC Controller PCA provides drive signals for the Registration Assembly Clutch (CL1), Paper Input Unit Clutch (CL2), and the Tray 1 Feed Clutch. The External Paper Handling PCA mounted on the Formatter Assembly provides the control signals for the clutches in the 2000-sheet Input Tray, 8-bin Mailbox/5-bin Mailbox with Stapler, 2 x 500-sheet Input Tray, and 7-bin Tabletop Mailbox.

Note

Refer to figure 5-2 for details.

Engine Test Microswitch

The Engine Test Microswitch, located on the top side of the DC Controller PCA, is activated manually through the square access hole at the top right side of the printer (Figure 6-6). This switch causes the print engine to perform an internal self test diagnostic which bypasses the Formatter PCA and then prints a full page of black parallel lines. This test is useful for troubleshooting printer problems because it isolates the print engine from the Formatter PCA. The engine test printout prints from Tray 3 only and can be activated with the Formatter PCA removed. A continuous test is performed indefinitely if the test button is held in. For more information, see Engine Test in Figure 7-10.

Motors

See the General Timing Diagram (figure 5-29 on page 183) for specific timing details for the printer motors.

The Main Motor, **MT1**, is controlled by the DC Controller PCA. The Main Motor drives the Main Gear Assembly and rotates during the Initial Rotation period (following power-on), the Print period, the Last Rotation Period, or whenever the printer front door is opened and closed.

The Scanner Motor is controlled and monitored by the DC Controller. It rotates the laser/scanner mirror during the Initial Rotation period and the Print period.

The Fan Motors are controlled and monitored by the DC Controller PCA. All five fans operate at full speed during the printing modes. All five fans turn off in the PowerSave mode after the Fuser cools down.

The drive signal for the Tray 2 and 3 Paper Pickup Motor, **SMT1**, is provided by the DC Controller PCA through the Paper Input Unit (PIU) PCA mounted on the right side of the PIU. When the job instructions call for paper to be supplied by Tray 2, SMT1 rotates in a forward direction and drives the Pickup roller for Tray 2. When paper is supplied by Tray 3, SMT1 rotates in the reverse direction and drives the Pickup roller for Tray 3.

Image Formation System

Laser printing requires the interaction of several different technologies (such as electronics, optics, and electrophotographics) to provide a printed page. Each process functions independently and must be coordinated with the other printer processes. The image formation process consists of six steps:

- 1 Drum Cleaning
- 2 Drum Conditioning
- 3 Image Writing
- 4 Image Developing
- 5 Image Transferring and Media Separation
- 6 Image Fusing

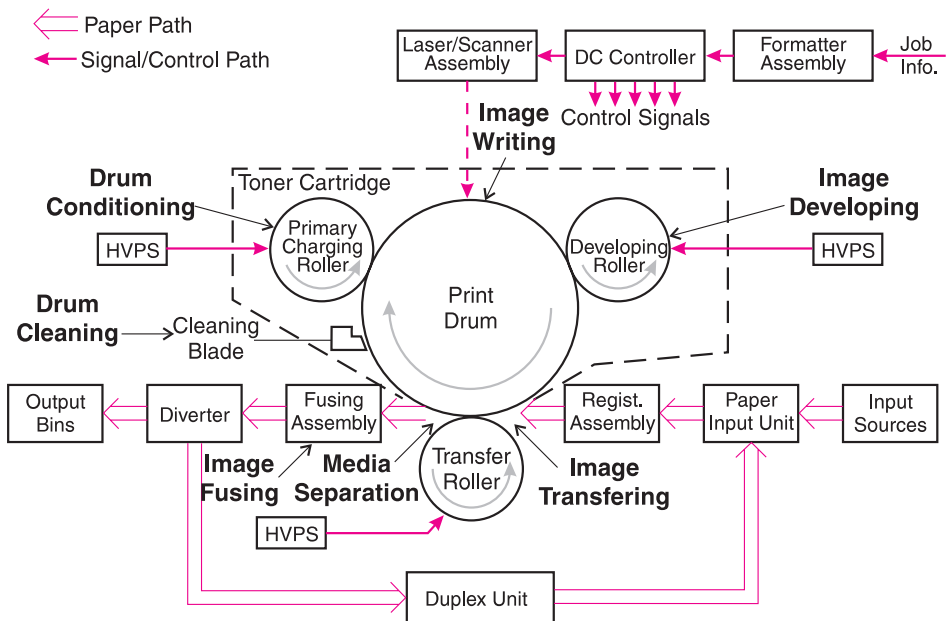

Figure 5-6 Image Formation Block Diagram

Toner Cartridge

The toner cartridge is the “heart” of the Image Formation System. It houses the cleaning, conditioning, and developing steps of the process. The toner cartridge contains the photosensitive drum, primary charging roller, developing station, toner cavity, and cleaning station. Including the components that wear, degrade, or are consumed in a customer-replaceable toner cartridge eliminates the need for a service call when replacement is required.

Toner Cartridge/High Voltage Power Supply Contacts

The toner cartridge has three contacts that route voltage from the HVPS PCA. They are:

- Upper: Primary Charge
- Middle: Developing Bias
- Lower: Toner Sensing/Toner Recognition

The Photosensitive Drum

The image from the Laser/Scanner Assembly is written on the drum surface, developed, and transferred to the media. The drum is an aluminum cylinder. The aluminum base of the photosensitive drum is electrically connected to ground potential. The outside of the cylinder is coated with a layer of non-toxic organic-photoconductive (OPC) material. The OPC material becomes electrically conductive when exposed to light. The drum surface is first cleaned of excess toner, then conditioned with a uniform negative charge. When an area on the drum surface is exposed to the laser light beam, the negative charge in that area is conducted to the ground potential of the drum base and thus becomes more positive. Areas not exposed to light remain non-conductive and maintain their negative charge.

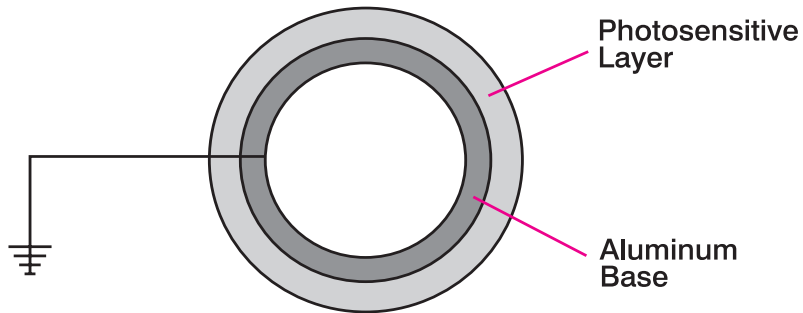

Figure 5-7 Photosensitive Drum

Drum Cleaning

The cleaning blade inside the toner cartridge is in contact with the surface of the drum at all times. As the drum rotates during printing, excess toner is removed from the drum surface and stored in the waste toner receptacle inside the toner cartridge.

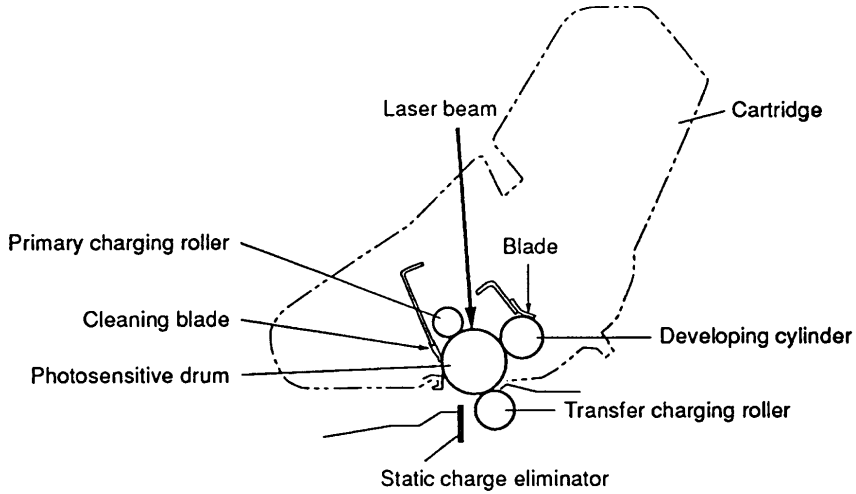

Figure 5-8 Drum Cleaning

Drum Conditioning

After the drum is physically cleaned, it is conditioned by applying a uniform negative charge across the surface of the drum with the primary charging roller, located in the toner cartridge. The primary charging roller is coated with conductive rubber, charged with an AC current that erases any residual charges, and produces a uniform drum surface potential. The AC current is centered around a negative DC bias which changes according to the Print Density setting.

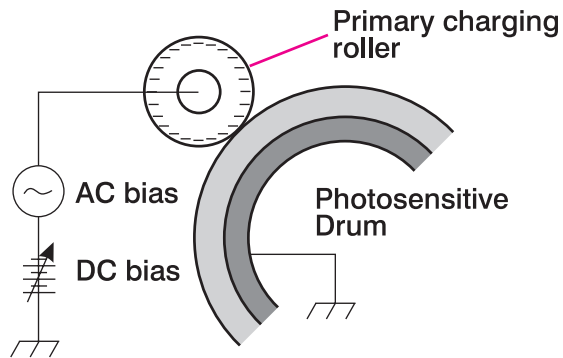

Figure 5-9 Primary Charging Roller

Image Writing

During the writing process, a modulated laser diode projects a beam onto a rotating six-sided scanning mirror. As the scanning mirror rotates, the beam is directed through a set of focusing lenses to another mirror that reflects it through a slot on the top of the toner cartridge and onto the photosensitive drum. The beam sweeps across the drum and discharges the negative potential wherever it strikes the surface. This creates a latent (invisible) electrostatic image, which is developed into a visible image as the drum rotates (see figure 5-10).

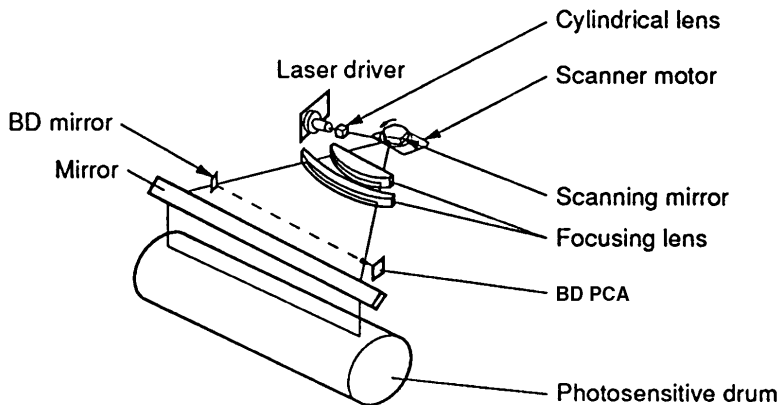

Figure 5-10 Image Writing

Because the beam is sweeping the entire length of the drum and the drum is rotating, the entire surface area of the drum can be covered. The speed of the laser/scanner motor (which turns the scanning mirror) and the speed of the main motor (which turns the drum) are synchronized, and each successive sweep of the beam is offset $1/600$ th of an inch. The beam can be turned on and off to place a dot of light every $1/600$ th of an inch. This is how the printer achieves its 600 x 600 dpi resolution. After the writing process, the drum surface has a latent (invisible) electrostatic image.

At the end of each sweep, the beam strikes the beam detect lens, generating the Beam Detect (BD) signal. The BD signal is sent to the DC Controller, where it is converted to an electrical signal used to synchronize the output of data (VDO) for one sweep (scan line) and to diagnose problems with the laser diode or laser/scanner motor.

FastRes 1200

FastRes 1200 (PCL 6 only) is an HP developed technology that can represent each dot space as one of four different levels of black. However, FastRes 1200 uses only 2 data bits to store information for the same dot space. This means that only half as much RAM is needed to print an image.

FastRes 1200 takes advantage of HP's new smaller toner particle (less than 5 microns) to provide superb test and image quality.

Image Developing

The developing process changes the latent electrostatic image into a visible image by depositing negatively charged toner particles on the exposed areas of the drum. The developing station is located inside the toner cartridge and consists of a metallic cylinder that rotates around a fixed magnetic core.

The developing cylinder is charged with an AC current that is centered around a negative DC bias. The AC current improves density and contrast by decreasing the attraction between the toner particles and the magnetic core of the cylinder. This increases the repelling action of the toner against the areas of the drum not exposed to laser light. The negative DC bias applied to the developing cylinder is also changed according to the Print Density setting. Both the primary charging roller and developing cylinder DC bias voltages are changed in response to the density setting. These changes in DC bias cause either more or less toner to be attracted to the drum, thus increasing or decreasing print density.

The toner is a powdery substance made of black plastic resin bound to iron particles. The toner particles are attracted to the magnetic core of the developing cylinder. A rubber blade “brushes” the toner on the developing cylinder to a uniform thickness.

The toner particles obtain a negative static charge by rubbing against the developing cylinder, which is charged with a negative DC bias. The negatively charged toner is attracted to the discharged (exposed, more positive) areas of the drum and repelled from the negatively charged (non-exposed) areas.

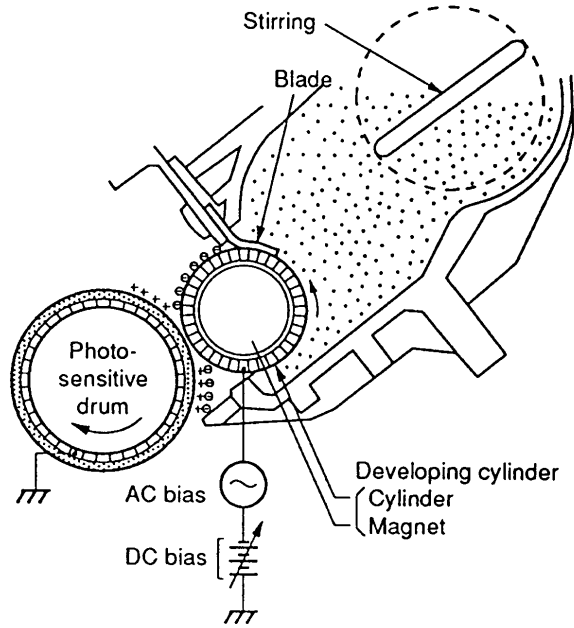

Figure 5-11 Image Development

Image Transferring and Media Separation

During the image transferring process, the toner image on the drum surface is transferred to the media. A positive charge applied to the back of the media by the transfer roller causes the negatively charged toner particles on the drum surface to be attracted to the media.

The small diameter of the drum, combined with the stiffness of the media, causes the media to separate easily from the drum. The static eliminator teeth also help separate the paper from the drum. The static eliminator teeth weaken the attractive forces between the negatively charged drum surface and the positively charged paper. This action keeps thin media from wrapping around the drum. After separation, the drum is cleaned and conditioned for the next image.

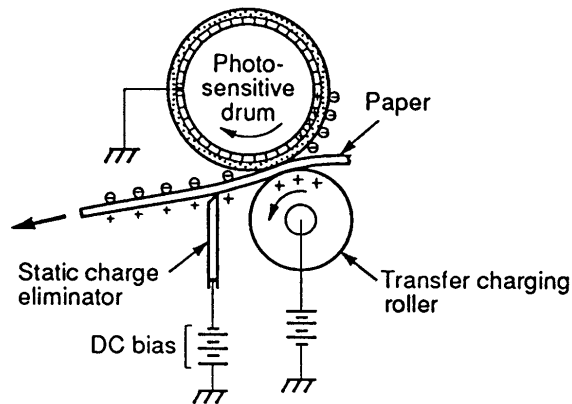

Figure 5-12 Image Transferring and Media Separation

Image Fusing

The Fusing Assembly bonds the toner particles into the media with a heated fusing roller and a soft pressure roller. There are two levers on the Fusing Assembly that adjust roller pressure for single sheets (down position) or envelopes (up position). Both levers must be set to the same position.

The fusing roller contains two quartz-halogen lamps that provide heat for the fusing process. Fusing temperature is monitored by the DC Controller PCA via thermistor TH1. The DC Controller maintains a temperature of about 190° C during print mode. If the fusing system overheats (about 230° C), TH1 opens, interrupting power to the fusing heater, causing a 50.X FUSER ERROR. If the fusing system exceeds 230° C, the thermal fuse opens, moving power away from the fuser.

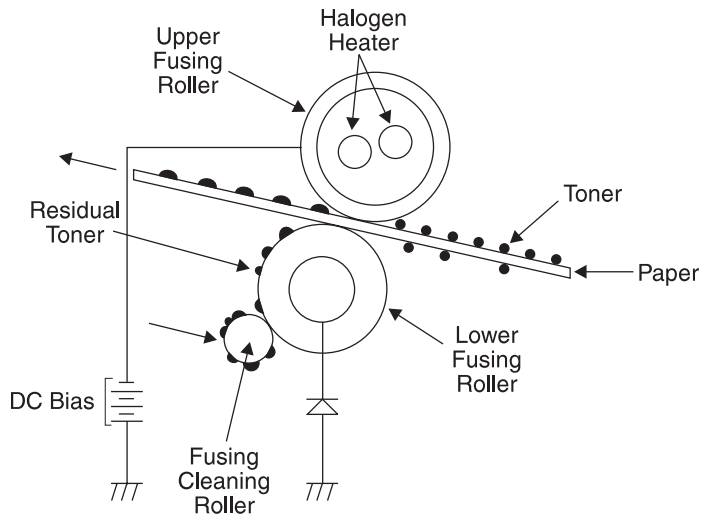

Figure 5-13 Image Fusing

Paper Paths and Components

Printer, Duplexer, and Envelope Feeder

The components of the printer paper path are illustrated in figure 5-14. Figure 5-15 and table 5-1 illustrate and describe all of the printer sensors, solenoids, clutches, motors, and fans.

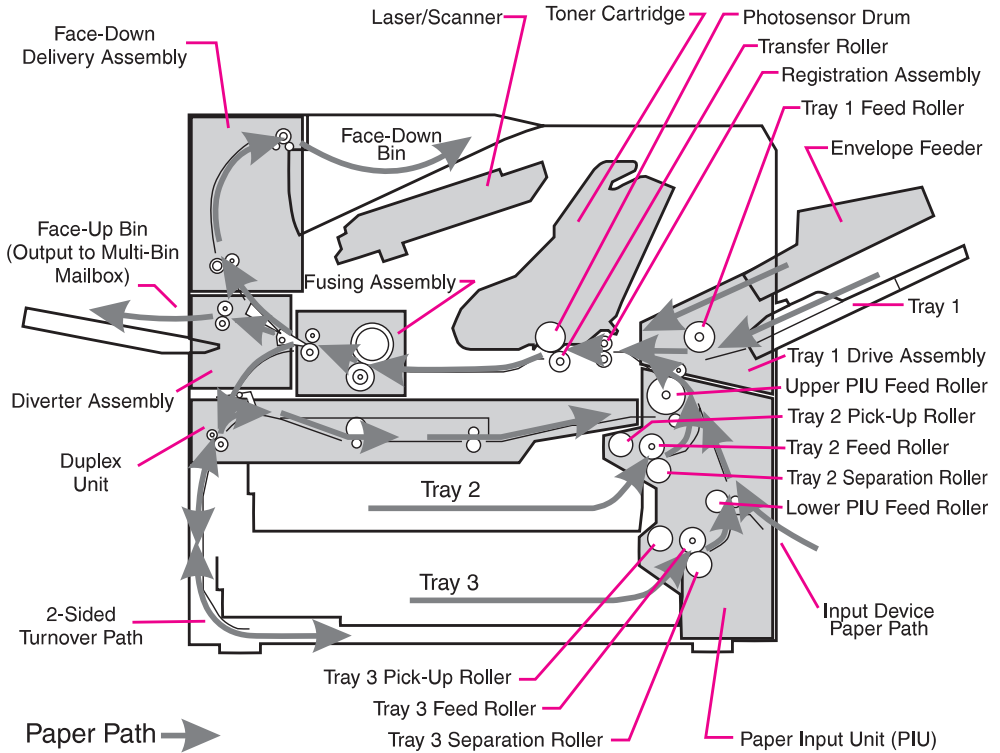

Figure 5-14 Printer Paper Paths

Table 5-1. Printer Sensors, Solenoids, Clutches, Motors, and Fans

Control Device	Title	Location
CL1	Registration Clutch	PIU (right side)
CL2	Paper Input Unit Feed Clutch	PIU (right side)
CL3	Tray 1 Feed Clutch	Tray 1 Drive Unit
Fan 1	Laser/Scanner Fan	Under Top Cover
Fan 2	Low Voltage Power Supply	LVPS
Fan 3	Formatter Fan	Below Formatter
Fan 4	Face-down Delivery Unit Fan	Under Top Cover
Fan 5	Tray 1 Fan	Tray 1 Assembly
MT1	Main Motor	Behind HVPS
PS1	Registration Paper Sensor	Registration Assembly (center)
PS2	Paper Input Unit Paper Sensor	Paper Input Unit (top, center)
PS1201	Tray 3 Paper Present Sensor	Paper Input Unit PCA
PS1202	Tray 2 Paper Present Sensor	Paper Input Unit PCA
PS1203	Tray 3 Paper Level Sensor 1	Paper Input Unit PCA
PS1204	Tray 3 Paper Level Sensor 2	Paper Input Unit PCA
PS1205	Tray 2 Paper Level Sensor 1	Paper Input Unit PCA
PS1206	Tray 2 Paper Level Sensor 2	Paper Input Unit PCA
PS1207	Tray 3 Paper Out Sensor	Paper Input Unit PCA
PS1208	Tray 2 Paper Out Sensor	Paper Input Unit PCA
PS1301	Tray 1 Paper Present Sensor	Tray 1 Drive Unit PCA
PS1302	Tray 1 Lifting Plate Position Sensor	Tray 1 Drive Unit PCA
PS1401	Face-down Bin Full Sensor	Switch/Sensor PCA
PS1402	Face-down Bin Delivery Sensor	Switch/Sensor PCA
PS1403	Fuser Delivery Sensor	Switch/Sensor PCA
SL1	Tray 2 and 3 Paper Pickup Solenoid	PIU (right side)
SL2	Tray 1 Lifting Plate Solenoid	Tray 1 Drive Unit
SL3	Face-up Bin Delivery Solenoid	Left Rear Corner of Chassis (behind diverter door)
SMT1	Tray 2 and 3 Paper Pickup Motor	PIU (right side)
SW1401	Doors Open Switch	Switch/Sensor PCA
Tray 2, SW1601	Tray 2 Paper Size Sensing Switch	Behind LVPS
Tray 2, SW1602	Tray 2 Paper Size Sensing Switch	Behind LVPS

Table 5-1. Printer Sensors, Solenoids, Clutches, Motors, and Fans (continued)

Control Device	Title	Location
Tray 2, SW1603	Tray 2 Paper Size Sensing Switch	Behind LVPS
Tray 2, SW1604	Tray 2 Paper Size Sensing Switch	Behind LVPS
Tray 3, SW1601	Tray 3 Paper Size Sensing Switch	Behind LVPS
Tray 3, SW1602	Tray 3 Paper Size Sensing Switch	Behind LVPS
Tray 3, SW1603	Tray 3 Paper Size Sensing Switch	Behind LVPS
Tray 3, SW1604	Tray 3 Paper Size Sensing Switch	Behind LVPS

Note See figure 5-15 for the locations of sensors, solenoids, clutches, motors and fans in table 5-1.

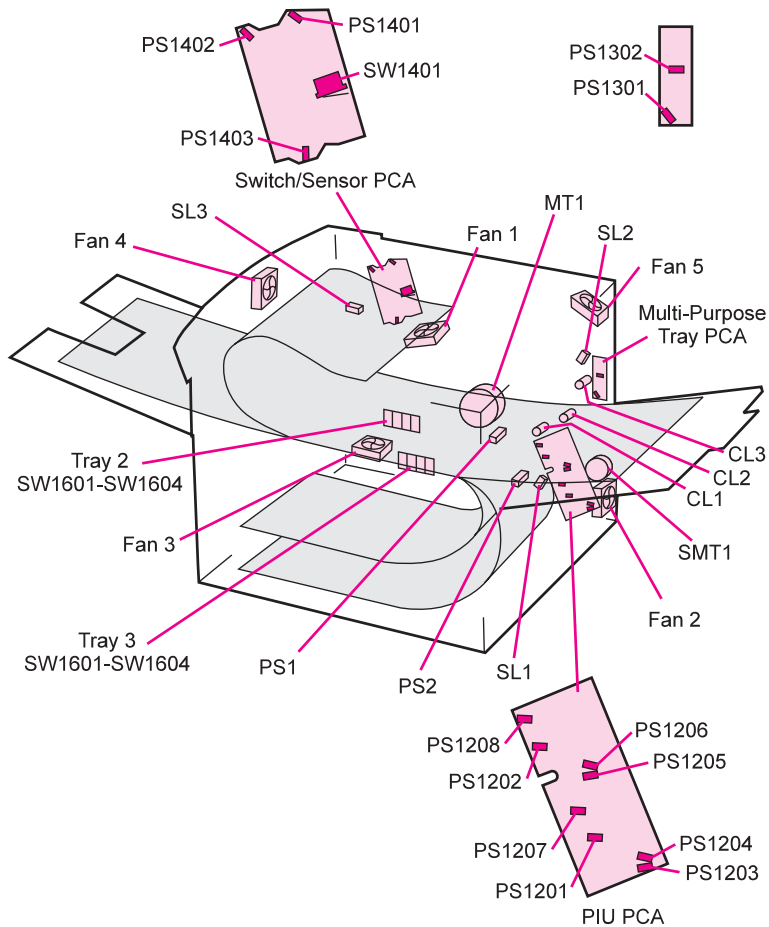

Figure 5-15 Printer Sensors, Solenoids, Clutches, Motors, and Fans

Paper Size Switches (Trays 2 and 3)

The paper guides in Trays 2 and 3 operate four levers at the back of the trays that activate the size sensing switches (SW1601 through SW1604) mounted in the printer chassis. Paper sizes are compared to switch conditions in table 5-2.

Table 5-2. Paper Size Switches

Paper Size	SW1601	SW1602	SW1603	SW1604
Ledger (portrait)	OFF	OFF	OFF	OFF
A3 (portrait)	OFF	ON	OFF	OFF
B4 (portrait)	ON	OFF	OFF	OFF
Legal (portrait)	ON	ON	OFF	OFF
Letter (landscape)	OFF	OFF	OFF	ON
A4 (landscape)	OFF	OFF	ON	OFF

Printing from Tray 1

The presence of paper in Tray 1 is detected by the Tray 1 Paper Present Sensor (PS1301). The lifting plate pressurization solenoid (SL2) is then activated, releasing the plate that applies upward pressure on the paper and causing it to contact the Tray 1 pickup roller. The Tray 1 Feed Clutch (CL3) turns on at this time and feeds the paper from Tray 1 to the registration position.

The remainder of the Tray 1 print process is identical to the Tray 2 and 3 process, described in “Printing from Tray 1” on page 153.

Printing from Trays 2 and 3

The Pickup, Feed, and Separation rollers start rotating when the DC Controller receives the /PRNT signal from the Formatter PCA. Then, the DC Controller activates the Pickup Solenoid (SL1) and starts feeding paper through the Paper Input Unit (PIU), triggering photosensors PS2 and then PS1. These sensors inform the DC Controller that paper has passed through the PIU and is present at the Registration Assembly.

When the Laser/Scanner and Fuser are ready, the DC Controller sends the /VSREQ signal to the Formatter. When the Formatter has processed the print data, it sends the /VSYNC and /VDO signals to the DC Controller. The paper is then released from the Registration Assembly (by CL1) and fed to the photosensitive drum, starting the

image transfer and fusing processes. After the paper passes through the Fuser, it triggers PS1403 and PS1402 to the specified type, size, and destination of the paper being fed through the printer.

Printing from the Envelope Feeder

The Envelope Feeder mounts in slots above Tray 1. The printer can print from Tray 1 even during the installation of the Envelope Feeder. When the print job calls for an envelope, it is fed directly to the Registration Assembly. From there, the print process is identical to the Tray 2 and 3 process, described in “Printing from Tray 1” on page 153.

Printing with the Duplexer

The duplexer mounts inside the printer below the Fusing Assembly. The back side of the paper is printed first, the paper is turned over, and then fed back to the Registration Assembly for front side printing. When the print job calls for 2-sided printing, a solenoid in the duplexer operates the duplex flipper in the Diverter Assembly and routes the paper to the duplexer. The paper does not exit the printer when being turned over for 2-sided printing. It is routed through a slot in the back of the duplexer, down inside the left cover and under Tray 3. When the duplexer senses the trailing edge of the paper, it reverses direction and feeds the paper back through the duplexer to the Registration Assembly.

2000-sheet Input Tray (Tray 4) Components

The HP 2000-sheet Input Tray now supports variable engine input speeds, ranging from 6 to 32 ppm. The 2000-sheet Input Tray also automatically senses paper size. Figure 5-16 illustrates the paper path components in the 2000-sheet Input Tray. Table 5-3 and figure 5-17 describe and illustrate the sensors, switches, clutches, and motors on the 2000-sheet Input Tray.

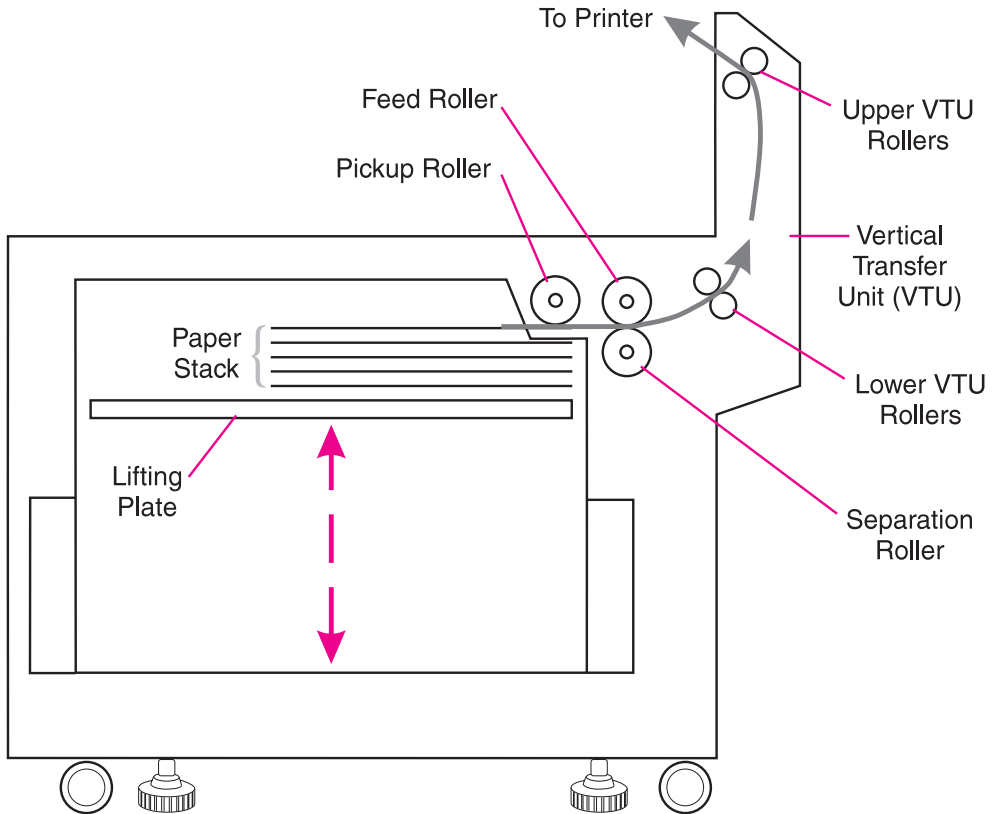

Figure 5-16 2000-sheet Input Tray Paper Path

Table 5-3. 2000-sheet Input Tray Sensors, Switches, Clutches and Motors

Control Device	Description	Location
CL31	Vertical Transfer Unit (VTU) Clutch	Vertical Transfer Unit (VTU)
CL32	Main Drive Clutch	VTU
MT31	Main Motor	Paper Deck Drive Assembly
PS31	Paper Entry Sensor	VTU
PS32	Paper Exit Sensor	VTU
PS33	Paper Tray Empty Sensor	Paper Pickup Assembly
PS34	Paper Tray Raised Sensor	Paper Pickup Assembly
PS35	VTU Closed Sensor	Paper Pickup Assembly
SW601-SW602	Paper Quantity Switches	Lower Chassis
SW701-SW704	Paper Size Switches	Lower Chassis
Power Supply Switch	Normal/Diagnostic Mode Switch	Power Supply
VTU Motor	Vertical Transfer Unit Motor for entry and exit rollers	VTU

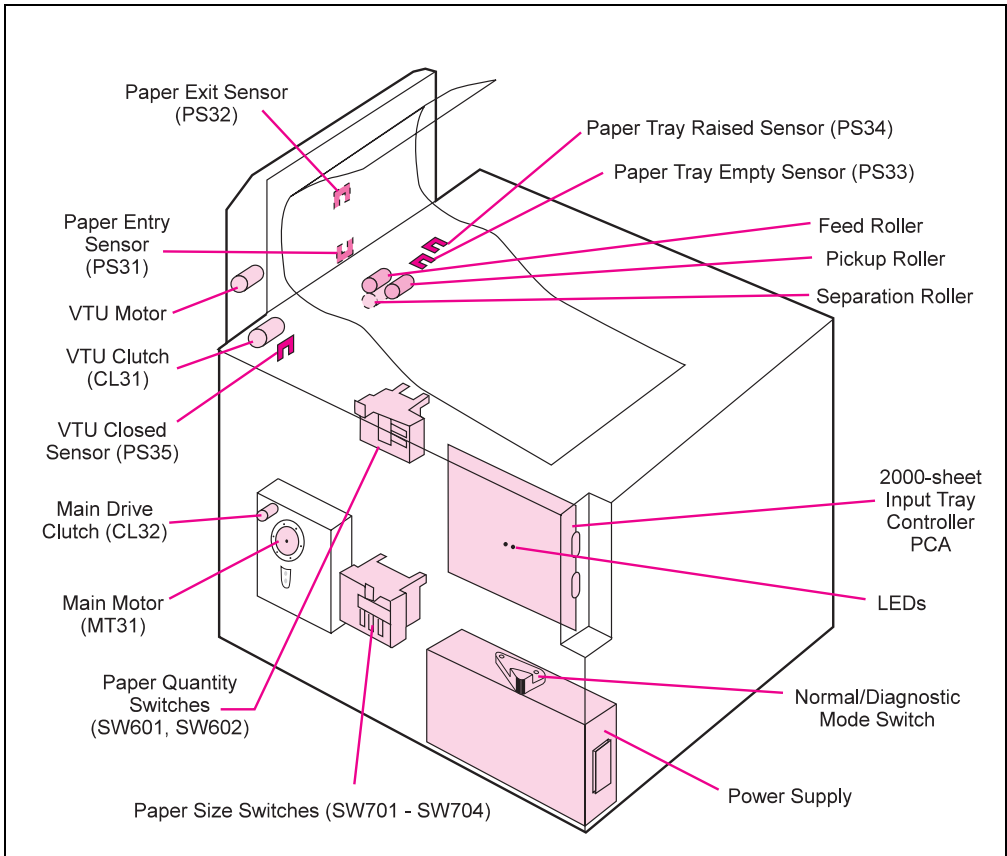

Figure 5-17 2000-sheet Input Tray Sensors, Switches, Clutches, and Motors

2000-Sheet Input Tray Operation

Pickup and Feed System

When the 2000-sheet Input Tray is loaded with paper and the paper tray is closed, the paper stack moves into position under the Pickup, Feed, and Separation Rollers. This operation is detected by the PS34 sensor in the 2000-sheet Input Tray's Pickup Assembly. The presence of paper in the paper tray is detected by the PS33 sensor. The paper level is detected by switches SW601 and SW602 in the Paper Quantity Switch Assembly. The paper size is detected by switches SW701 through SW704 in the Paper Size Switch Assembly. Tables 5-4 and 5-5 show the paper quantity and paper size switches on the 2000-sheet Input Tray.

Table 5-4. 2000-sheet Input Tray Paper Quantity Switches

SW601	SW602	Remaining Paper
Off	Off	100%
On	Off	75%
On	On	50%
Off	On	25%

Table 5-5. 2000-sheet Input Tray Paper Size Switches

Paper Size	SW701	SW702	SW703	SW704
Ledger (portrait)	Off	On	Off	Off
A3 (portrait)	On	On	Off	Off
B4 (portrait)	Off	Off	On	Off
Legal (portrait)	Off	On	On	Off
Letter (landscape)	Off	On	Off	On
A4 (landscape)	On	On	Off	On

When the Paper Handling Controller on the printer sends an input command to the Controller PCA on the 2000-sheet Input Tray, the Paper Deck Driver runs the Pickup Motor to rotate the Pickup, Feed, and Separation Rollers. As the Pickup Roller turns, the paper feeds into the Vertical Transfer Unit (VTU) and passes through the PS31 and PS32 sensors.

If the paper fails to reach the PS31 and PS32 sensors in the VTU within the allotted time, the Controller PCA on the 2000-sheet Input Tray assumes that a paper jam has occurred. The 2000-sheet Input Tray stops the operation and reports the paper jam to the Paper Handling Controller on the printer. A paper jam message appears on the printer control panel display.

Hardware malfunctions are also displayed on the printer control panel.

Lifter Operation

The lifter plate in the 2000-sheet Input Tray's paper tray is held by two wires that are wound on four pulleys by the Lifter Motor. When the paper tray is open, the pulley gears disengage from the motor gears, and the Lifter lowers by its own weight. The presence or absence of the tray is detected by switches SW701 through SW704 on the unit's Paper/Tray Size Switch Assembly.

After the paper tray is closed, the Lifter Motor lifts the paper stack into position; this action is detected by the PS34 sensor. The PS34 sensor also maintains the height of the paper stack. As paper is picked up by the rollers, the number of sheets decreases. Once the paper stack decreases to a certain level, the PS34 sensor registers a low condition. Then the Paper Deck Driver turns on the Lifter Motor again and lifts the paper stack until the PS34 sensor registers sufficient paper in the tray.

Power Supply

The 2000-sheet Input Tray has an internal Power Supply that activates when the printer's power switch is turned on. The Paper Handling Controller on the printer sends a power-on signal to the Power Supply on the 2000-sheet Input Tray through the Controller PCA on the 2000-sheet Input Tray. When the signal is high, the Power Supply provides both +24V and +5V to the Paper Deck Driver. The +24V drives the motors, clutches, and solenoids for the lifter, feed, and pickup systems. The +5V drives the sensors and PCA electronics.

Printing from the 2000-sheet Input Tray (Tray 4) or 2 x 500-sheet Input Tray (Trays 4 and 5)

Trays 4 and 5 feed the paper upward through a guide slot in the Lower Right Door Assembly to the Paper Input Unit. Once there, the operation is the same as printing from Trays 2 and 3, described in "Printing from Tray 1" on page 153.

2 x 500-sheet Input Tray

The 2 x 500-sheet Input Tray is an input paper handling device that provides two additional input trays that hold up to 500 sheets each. The device is designed to support different printer platforms with variable engine input speeds, from 6 to 32 pages per minute, and provide storage space for printer supplies or consumables. The device has automatic paper size sensing and enhanced network management capabilities.

The 2 x 500-sheet Input Tray paper path is shown in figure 5-18.

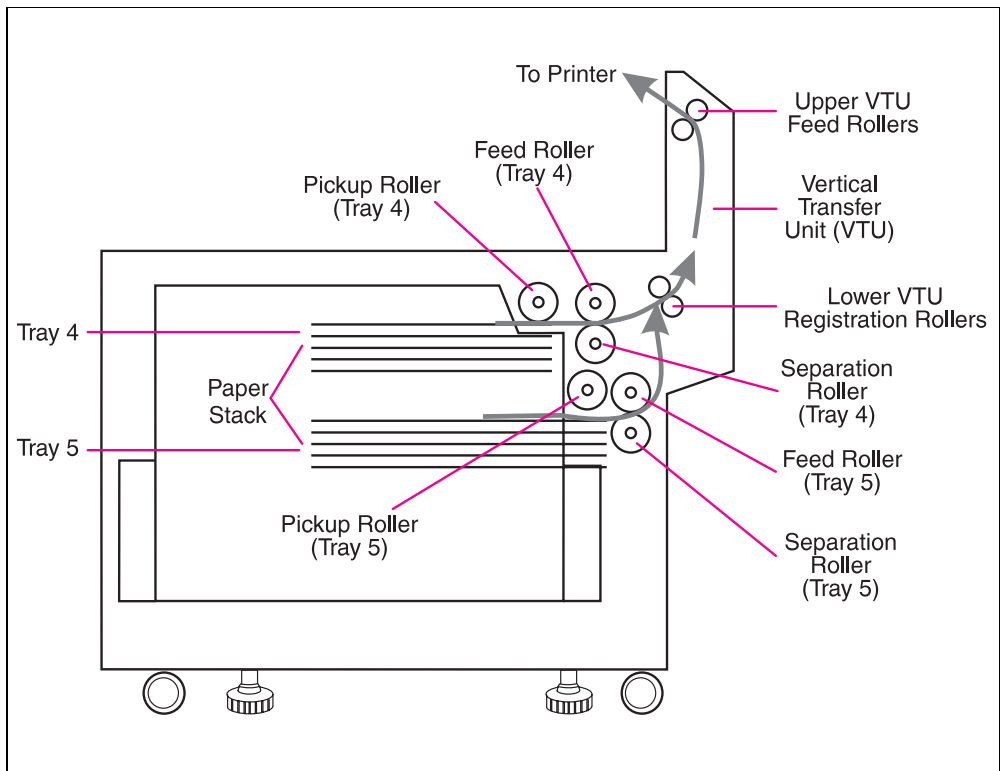

Figure 5-18 2 x 500-sheet Input Tray Paper Path

Table 5-6. 2 x 500-sheet Input Tray Sensors, Switches, and Motors

Control Device	Title	Location
PS1203	Lower Cassette Paper Level Sensor 1	Pickup Assembly PCA
PS1204	Lower Cassette Paper Level Sensor 2	Pickup Assembly PCA
PS1201	Lower Cassette Sensor	Pickup Assembly PCA
PS 1208	Upper Cassette Paper Out Sensor	Pickup Assembly PCA
PS 1206	Upper Cassette Paper Level Sensor 2	Pickup Assembly PCA
PS 1205	Upper Cassette Paper Level Sensor 1	Pickup Assembly PCA
PS2	Paper Jam Sensor	Vertical Transfer Unit (VTU)
CL31	VTU Clutch	VTU
PS35	VTU Closed and Open Sensor	Pickup Assembly
SW1601-SW1604	Paper Size Switches	Back Lower Chassis
Power Supply Switch	Normal/Diagnostic Mode Switch	Power Supply
VTU Motor	Vertical Transfer Unit for entry and exit rollers	VTU

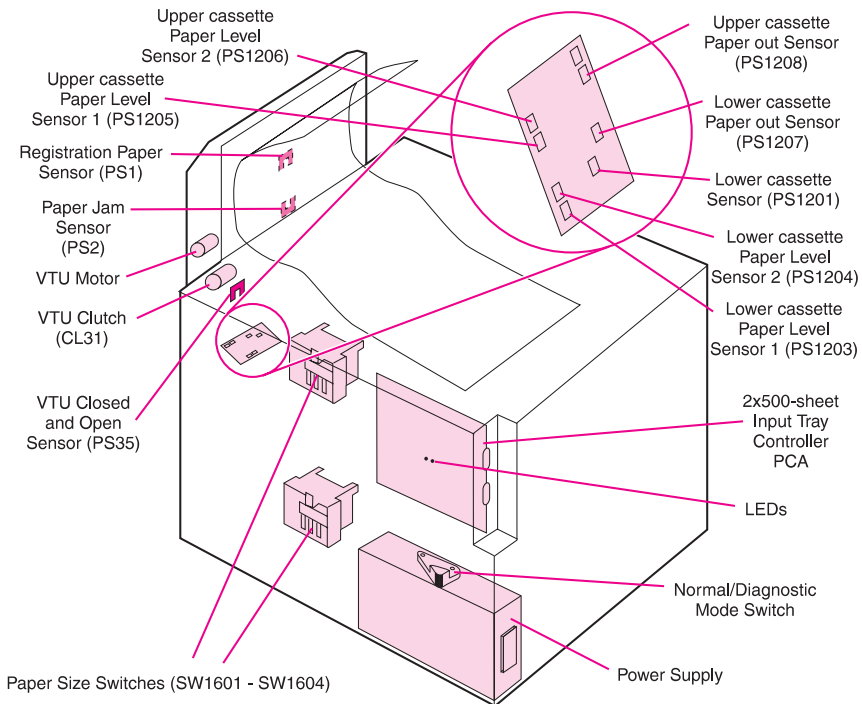

Figure 5-19 2 x 500-sheet input Tray Sensors and Switches

2 x 500-sheet Input Tray Operation

Communication and control of the input device are made through the Paper Handling Controller by a sequence of instructions controlled into the 2 x 500-sheet Input Tray controller PCA.

Pickup and Feed System

When each tray in the 2 x 500-sheet Input Tray is loaded with paper and the paper tray is closed, the paper stack moves into position under the Pickup, Feed, and Separation Rollers. The trays are detected by the PS1202 sensor in the upper tray and by the PS1201 sensor in the lower tray. The presence of paper is detected in the upper paper tray by the PS1208 sensor, and in the lower tray by sensor PS1207. The paper level is detected by switches SW1205 and SW1206 in the upper tray, and by switches SW1203 and SW1204 in the lower tray. The paper size is detected by switches SW1601 through SW1604 installed in each tray.

Table 5-7. 2 x 500-sheet Input Tray Switches

Paper Size	SW1601	SW1602	SW1603	SW1604
Ledger (Portrait)	OFF	OFF	OFF	OFF
A3 (Portrait)	OFF	ON	OFF	OFF
B4 (Portrait)	ON	OFF	OFF	OFF
Legal (Portrait)	ON	ON	OFF	OFF
Letter (Landscape)	OFF	OFF	OFF	ON
A4 (Landscape)	OFF	OFF	ON	OFF

When the Paper Handling Controller in the printer sends an input command to the Controller PCA on the 2 x 500-sheet Input Tray, the 2 x 500-sheet Input Tray driver engages the Pickup Motor to rotate the Pickup, Feed, and Separation Rollers. The direction of rotation of the Pickup motor determines which set of rollers are activated. When the motor rotates clockwise, the paper is picked up from the upper tray, and when the motor rotates counterclockwise, the paper is picked up from the lower tray. The 2 x 500-sheet Input Tray driver also engages the 2 x 500-sheet Input Tray motor to activate the Pickup Solenoid, which lowers the rollers to the level of the paper. As the Pickup Roller turns, the paper feeds into the Vertical Transfer Unit (VTU) and passes through the PS1 and PS2 sensors.

If the paper fails to reach the PS1 and PS2 sensors in the VTU within the allotted time, the Controller PCA on the 2 x 500-sheet Input Tray assumes that a paper jam has occurred. The 2 x 500-sheet Input Tray stops the operation and reports the paper jam to the Paper Handling Controller on the printer. A paper jam message appears on the printer control panel display.

Hardware malfunctions are also displayed on the printer control panel.

Lifter Operation

The 2 x 500-sheet Input Tray drive motor lifts the paper when a tray is installed and when the pickup roller is lowered as a result of a partially filled tray.

When a tray is installed, the Paper Pickup Solenoid SL3 is turned on. The movements of the shaft drive arm and the lift-up release arm free the lift-up cam. This advances the lifter gear one tooth at a time, raising the lifting plate. When the paper on the lifting plate engages the pickup roller, the lift-up cam is stopped from rotating, and the lifting operation is completed.

When the paper falls below a set level, the actions are the same to lift the plate, except the position of the pickup roller (which is lowered as paper is used) triggers the lift-up release arm to free the lift-up cam, advancing the lifter gear. The lifting operation terminates the same way in both cases, triggered by contact between the paper in the tray and the pickup roller.

Power Supply

The 2 x 500-sheet Input Tray has an internal power supply activated when the printer power switch has been turned on. The Paper Handling Controller sends a power-on signal to the power supply through the 2 x 500-sheet Input Tray controller. When the signal is high, the power supply provides +24V and +5V to the paper deck driver. The +24V is used to drive the lifter, Feed, Pickup motors, clutches, and solenoids; +5V drives sensors and PCA electronics.

7-bin Tabletop Mailbox Components

Components of the 7-bin Tabletop Mailbox paper path, including mailbox sensors, switches and motors, are illustrated in figure 5-20 and figure 5-21 and described in table below.

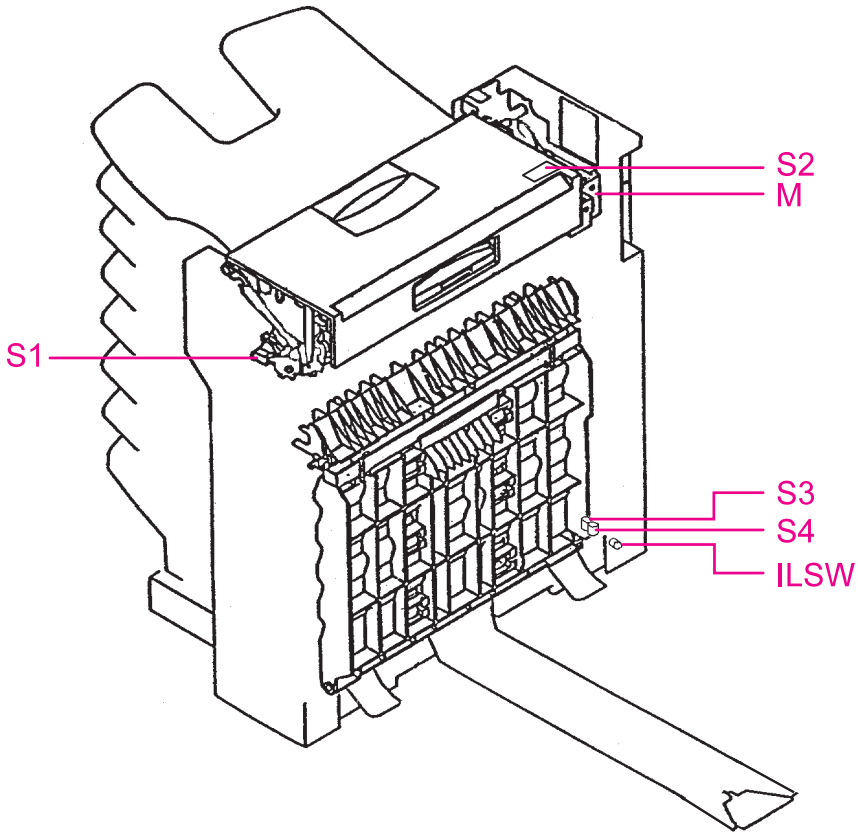

Figure 5-20 7-bin Tabletop Mailbox Components (1 of 2)

Table 5-8. 7-bin Tabletop Mailbox Sensors, Switches, and Motors

Control Device	Title	Location
M	Motor	Upper back side
S1	Face-up/down Diverter Solenoid	Upper front side
S2	Reversing mechanism solenoid	Right side of the motor
S3	Diverter solenoid (bins 1, 3, and 5)	Bottom back side
S4	Diverter solenoid (bins 2, 4, and 6)	Bottom back side
BES1 to 7	Bin empty sensors (1 to 7)	Surface of every Face-down Bin
BFS1 to 7	Bin full sensors (1 to 7)	Upper left side of every Face-down Bin entrance
FUBFS	Face-up Bin full sensor	Upper center of the Face-up Bin entrance
ES	Paper entry sensor	Paper entrance
FUDS	Face-up Delivery Sensor	Rev. assembly. (top cover)
PPS1	Paper path sensor 1	Inside the unit, down the entry rollers.
PPS2	Paper path sensor 2	Paper path (right cover)
ILSW	Interlock switch	Bottom right side

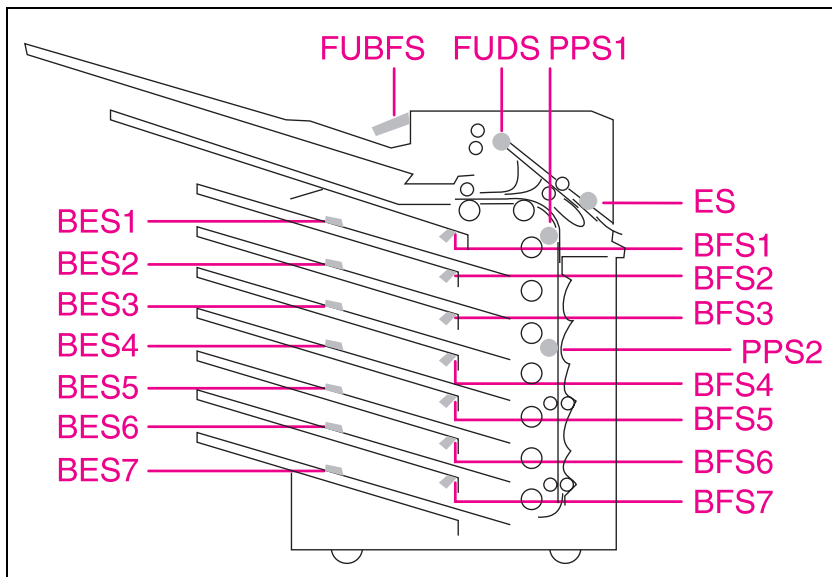

Figure 5-21 7-bin Tabletop Mailbox Components (2 of 2)

7-bin Tabletop Mailbox Operation

The 7-bin Tabletop Mailbox is a low cost output device designed to support different printer platforms at variable engine input speeds and to increase office productivity. The mailbox has a total capacity of 940 sheets distributed in 7x120 Face-down bins and a 1x100 Face-up Bin, and works with four intelligent and configurable operating modes.

An additional optional product, the Stand for the 7-bin Tabletop Mailbox, allows the customer to attach the mailbox in a floor stand configuration when an input device is attached to the printer.

Power-on Sequence

During the power-on sequence, the mailbox runs an initialization routine. The motor will perform a complete cycle and solenoid S2, S3, and S4 will be activated in that order. At the end of this routine, the front cover LED will display a fixed green light, but if there is a problem, the LED will flash red.

The information from the paper handling controller is carried by the C-link cables that connect the controller board for all of the C-link protocol-supported devices. The C-link protocol supports up to 5 devices connected to the paper handling controller in a Daisy Chain. Each device controller has an input and output port that provides them the flexibility of connection in different configurations. However, HP recommends using the configuration shown in figure 5-28 on page 181 to avoid rearrangements in the supported device numbering and confusion when evaluating the event log.

Receiving Paper

The engine delivers paper to the mailbox through the Face-up Delivery Slot (input paper guide) at 107 mm/sec. The entry sensor (ES) senses paper arrival, and then the Face-up/down Diverter Solenoid actuates only if the paper is going to the Face-up Bin. If the paper has to reach any Face-down Bin, this solenoid will not actuate and the paper will go into the reversing area.

Delivering Paper

If the paper is going to the Face-up Bin, the Face-up Delivery Sensor (FUDS) waits for the paper to reach the Face-up Bin. When the bin is full, the paper will actuate the Face-up Bin full sensor (FUBFS).

If the paper is sent to any of the Face-down bins, the reversing mechanism will be activated by the reversing mechanism solenoid (S2). The paper path sensor 1 (PPS1) will wait for paper, and the correct diverter solenoid will actuate to deliver the paper in the correct bin (S3 if the paper is going to bin numbers 1 through 3 or S4 for bin number 2).

If the paper has to reach other bins, then the paper path sensor 2 (PPS2) will be waiting for it. In the same way, S3 will be activated if the paper final destination is bin number 5, and if not, then S4 will be activated to reach bins 4 through 6. Finally, if the paper destination is bin number 7, none of the solenoids will be actuated. When a specific bin is full, then the paper will actuate the corresponding Face-down Bin full sensor (BFS1 to 7). The unit can report an empty bin condition to the engine based on the empty bin sensors (BES1 to 7).

Configuring the Operating Modes

The network administrator chooses the mode of operation through an HP network configuration utility, such as HP JetAdmin or HP LaserJet utility. You must set up your printer driver to reflect the mode chosen by the administrator.

Bidirectional environment: The printer automatically selects the mode established by the network administrator.

Unidirectional environment: The mode of operation can be changed in the driver. The method for changing the mode varies with the driver and type of operating system. For additional information, see the online help for the printer software.

Configurable Mailbox Mode (Default Configuration)

In this mode, each bin can be addressed individually as the output destination and can have a name assigned to it by the network or mopier administrator. All the jobs are placed in the Face-down bins. If the assigned bins are full, the printer halts or sends the next pages to the overflow bin, as defined by the MIS manager.

Job Separator Mode

- Print jobs are automatically sent one job per bin to the first empty bin beginning with the top bin. Non-empty bins are skipped. If all bins have paper, then the job will be sent to the first non-full bin starting at the top.
- If a bin fills during delivery, the system will stop. A control panel message indicates that paper needs to be removed before delivery to that bin can continue. Delivery of the job resumes in the same bin when paper is removed.
- To clear a device full condition, empty all bins.

Note

Use of an overflow bin can cause a job to be mixed in two bins.

Virtual Stacker Mode

In Virtual Stacker Mode, printed sheets are stacked face down in the bins from the lowest bin to the top bin, regardless of job boundaries. This mode of operation takes advantage of the total capacity of the mailbox bins. The software sees the mailbox as one logical bin. When the mailbox is full, the system will halt until all bins are emptied.

Collator Mode

- Copies of a print job are automatically sent one copy per bin beginning with the top bin.
- If there are more copies than bins, the delivery resumes sequentially from the top bin until all copies are delivered.
- If a bin fills during delivery, the system will stop. A control panel message indicates which bin is full, and will display a request to remove paper. Delivery of the copy resumes in the same bin when paper is removed.
- To clear a device full condition, empty all bins.

Note

Use of an overflow bin can cause a job to be mixed in two bins.

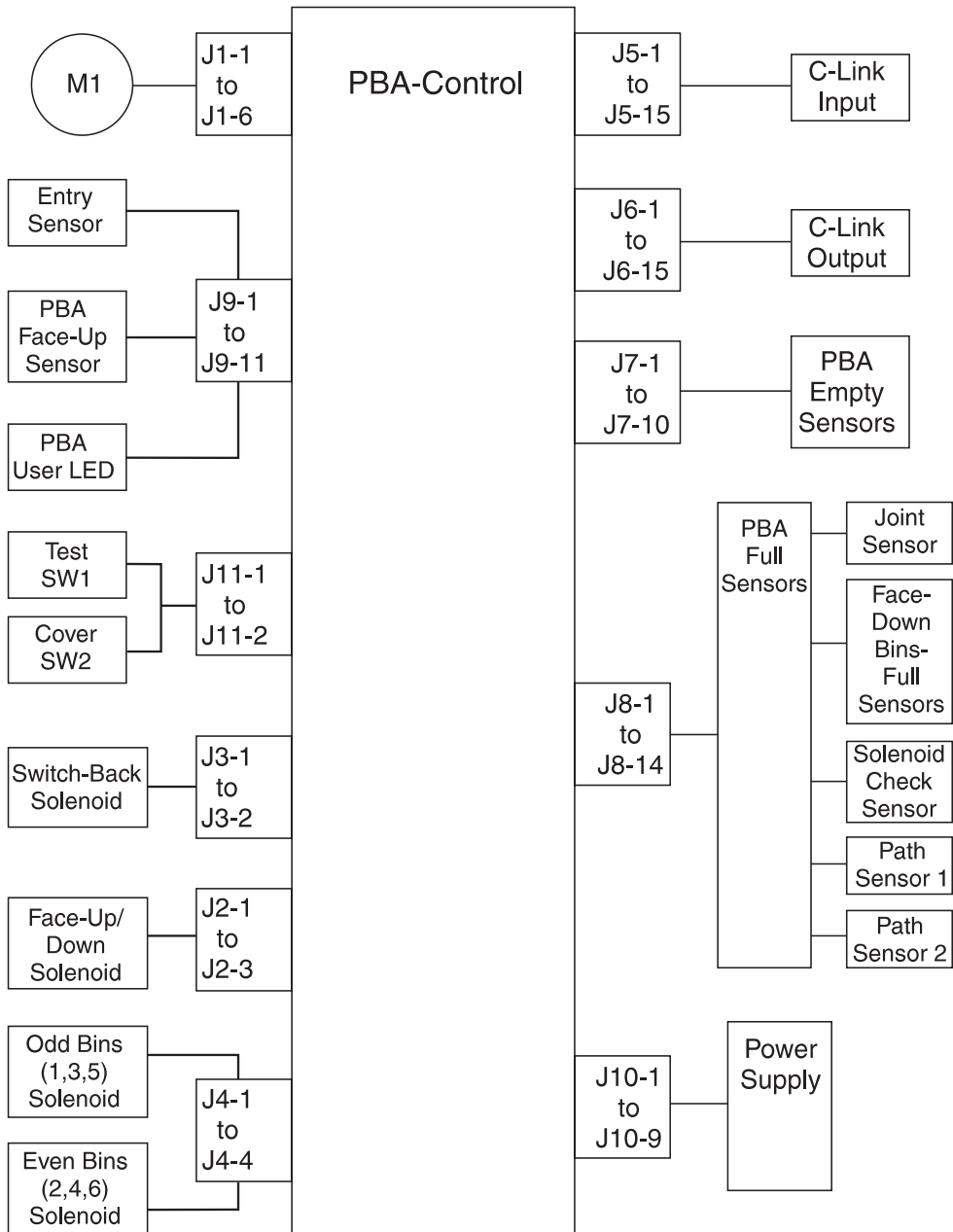

Figure 5-22 7-bin Tabletop Mailbox Block Diagram

8-bin Mailbox Components

The 8-bin Mailbox is an output unit designed for variable speeds, ranging from 6 to 32 ppm. The 8-bin Mailbox holds up to 2,100 sheets distributed in eight 250-sheet Face-down bins and one 100-sheet Face-up Bin. The 8-bin Mailbox also features four intelligent and configurable operating modes. Table 5-9 and figure 5-24 illustrate and describe the 8-bin Mailbox sensors, switches, motors, and Controller PCA. Figure 5-23 illustrates the components of the 8-bin Mailbox paper path.

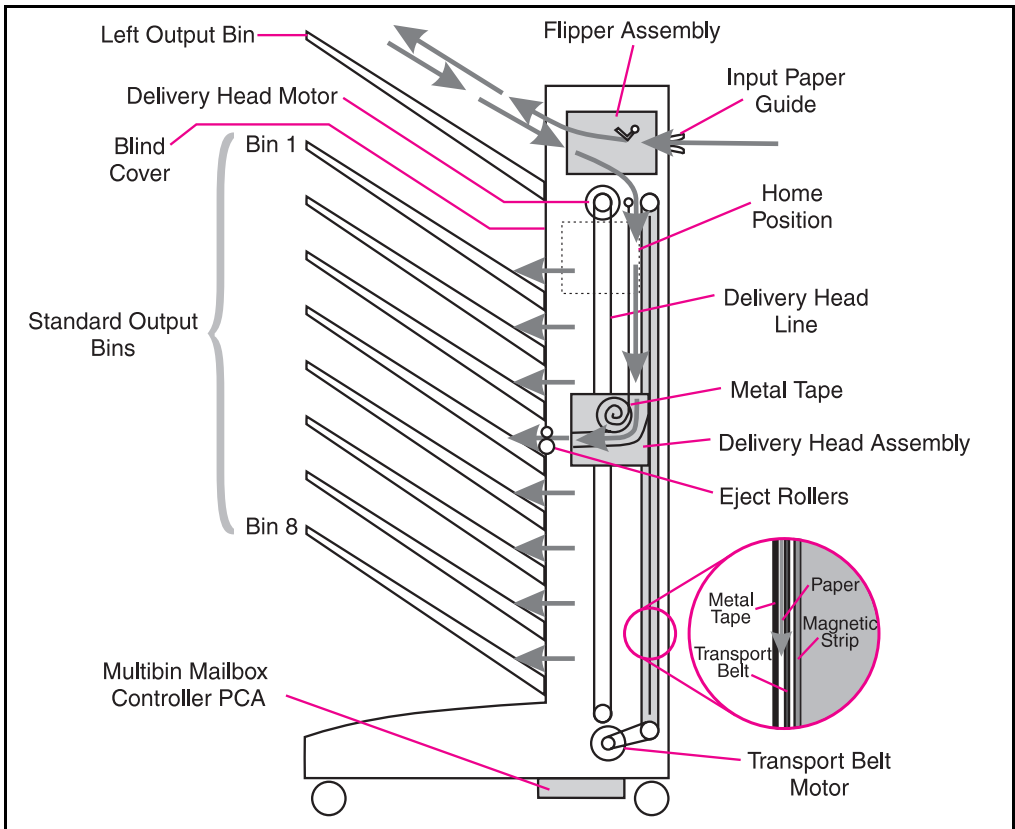

Figure 5-23 8-bin Mailbox Paper Path

Table 5-9. 8-bin Mailbox Sensors, Switches, Motors, and Controller PCA

Control Device	Description	Location
M1	Delivery Head Motor	Upper-back side
M2	Flipper Roller Motor with Encoder	Flipper Assembly (upper back)
M3	Delivery Head Roller Motor	Delivery Head Assembly (upper back)
M4	Ejector Motor	Under Delivery Head Assembly
M5	Transport Belt Motor	Lower-back side
PSBinEmpty	Paper Bin Empty Sensor	Delivery Head Assembly (upper back)
PSBinFull/ Head Position	Paper Bin (below) Full Sensor	Delivery Head Assembly (upper back)
PSEject	Delivery Rollers Extended Sensor	Delivery Head Assembly (upper back)
PSEntry	Paper Entry Sensor	Flipper Assembly (top, center)
PSExit1	Paper Delivered to Head Sensor	Delivery Head Assembly (upper back)
PSExit2	Paper Delivered to Bin Sensor	Delivery Head Assembly (upper back)
PSFaceUp	Reverse Stepper Motor Sensor	Flipper Assembly (top, center)
PSFaceFull	Face-up Bin Full Sensor	Flipper Assembly (top, center)
SW1	Interlock Switch	Middle-back Side
IR LED	Infrared Light-emitting Diode (for Stapler Assembly)	Delivery Head Assembly (left, center)

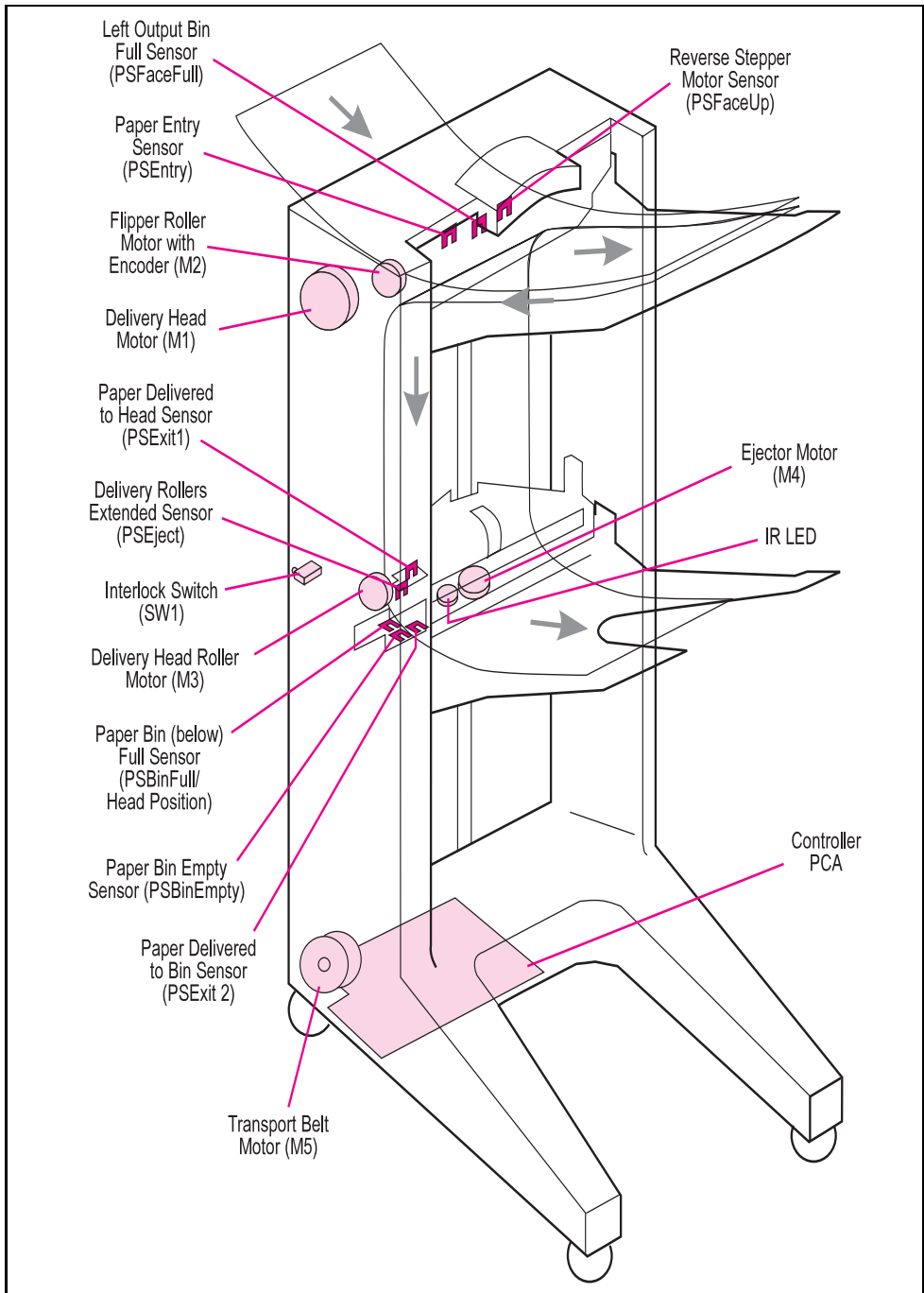

Figure 5-24 8-bin Mailbox Sensors, Switches, Motors, and Controller PCA

8-bin Mailbox Operation

Power-on Sequence

During the power-on sequence, the Delivery Head Assembly moves first to the top “home” position at the Face-up Bin. From that position the delivery head moves down, scanning to determine if all the Mailbox bins are installed, if they contain paper, and if they are full. Then the Delivery Head proceeds upward again to the home position and remains there for about 7 seconds. Finally, the Delivery Head Assembly moves to the bottom bin, where it waits for the next command from the Paper Handling Controller.

Note

If one of the bins has been removed or is not seated correctly, the Delivery Head Assembly will not complete the scan and will send an error message to the printer control panel.

Receiving Paper

The printer delivers paper to the 8-bin Mailbox through the left output delivery slot (Input Paper Guide) at a rate of 107 mm per second. Paper arrival is sensed by the PSEntry sensor, which activates the Flipper Roller Motor (M2), causing the paper to move through the 8-bin Mailbox transport and delivery system. See figure 5-23 on page 170.

Delivering Paper

The Delivery Head Assembly on the 8-bin Mailbox moves or stays in the indicated bin according to the commands coming from the Paper Handling Controller on the printer. If paper is designated for the Face-up Bin, the 8-bin Mailbox feeds it through the Flipper Assembly. If paper is designated for one of the Face-down bins, the 8-bin Mailbox feeds it through the Flipper Assembly until the trailing edge is sensed by the PSFaceUp sensor. Then the Flipper Roller Motor (M2) reverses and feeds the paper down between the Transport Belt and the Metal Tape until it reaches the Delivery Head Assembly.

Configuring the Operating Modes

The network administrator chooses the mode of operation through an HP network configuration utility, such as the HP JetAdmin utility or the HP LaserJet utility for the Macintosh. Additionally, on all workstations that print to the printer, the printer driver might need to be set up to reflect the chosen operating mode.

Mailbox Mode

In Mailbox Mode, the network administrator can address each bin as an output destination with a name assigned to it. The printer sends a print job to the selected bin. If the assigned bin is full, the printer either stops printing or sends subsequent pages to the overflow bin, which is also defined by the network administrator.

Job Separator Mode

- Print jobs are automatically sent one job per bin to the first empty bin beginning with the top bin. Non-empty bins are skipped. If all bins have paper, the job will be sent to the first non-full bin starting at the top.
- If a bin fills during delivery, the system will stop. A control panel message indicates that paper needs to be removed before delivery to that bin can continue. Delivery of the job resumes in the same bin when paper is removed.
- To clear a device full condition, empty all bins.

Note

Use of an overflow bin can cause a job to be mixed in two bins.

Virtual Stacker Mode

In Virtual Stacker Mode, printed sheets are stacked face down in the bins from the lowest bin to the top bin, regardless of job boundaries. This mode of operation takes advantage of the total capacity of the mailbox bins. The software sees the mailbox as one logical bin. When the mailbox is full, the system will halt until all bins are emptied.

Collator Mode

- Copies of a print job are automatically sent one copy per bin beginning with the top bin.
- If there are more copies than bins, the delivery resumes sequentially from the top bin until all copies are delivered.
- If a bin fills during delivery, the system will stop. A control panel message indicates which bin is full, and will display a request to remove paper. Delivery of the copy resumes in the same bin when paper is removed.
- To clear a device full condition, empty all bins.

Note

Use of an overflow bin can cause a job to be mixed in two bins.

Finisher Components

The 5-bin Mailbox with Stapler is an output-Finisher paper-handling device designed to work with different HP LaserJet printers. It has both mailbox and stapling capability. The stapler unit output bin staples up to 20 sheets (letter and A4,) 20-lb paper), and has a total capacity of 350 stapled sheets.

In addition, this component has 5 Face-down bins with a capacity of 250 sheets each, and 1 Face-up Bin with a capacity of 100 sheets, for a total capacity of 1350 non-stapled sheets. The 8-bin Mailbox and the 5-bin Mailbox with Stapler have similar functionality, performance, and parts. The stapler fits into the Mailbox by removing the three upper bins and the blind cover (see figure 8-14 on page 706 for location of the blind cover).

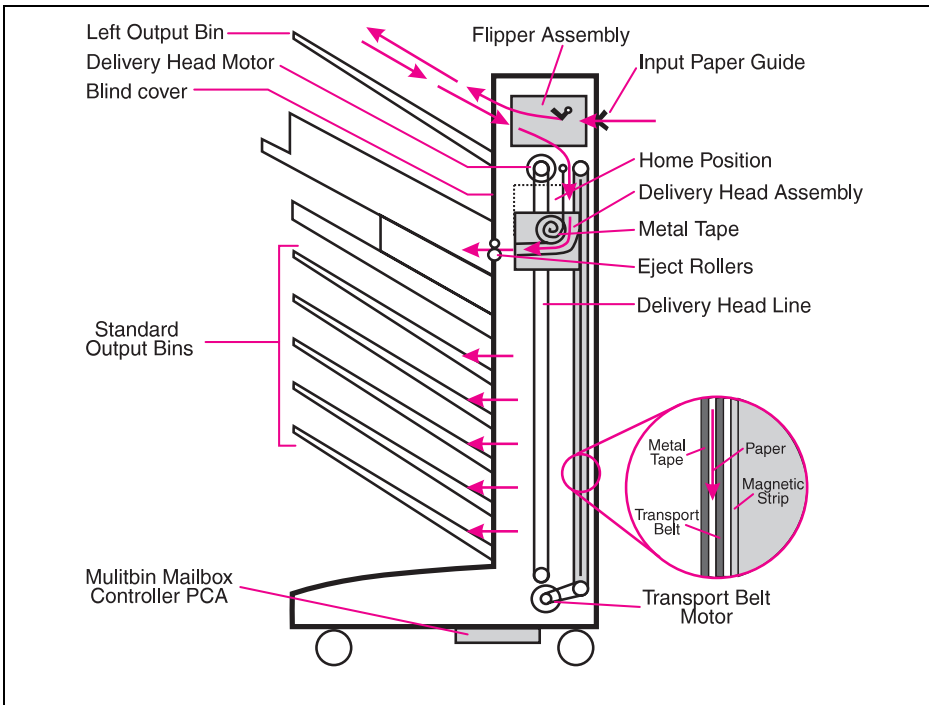

Figure 5-25 Finisher Paper Path

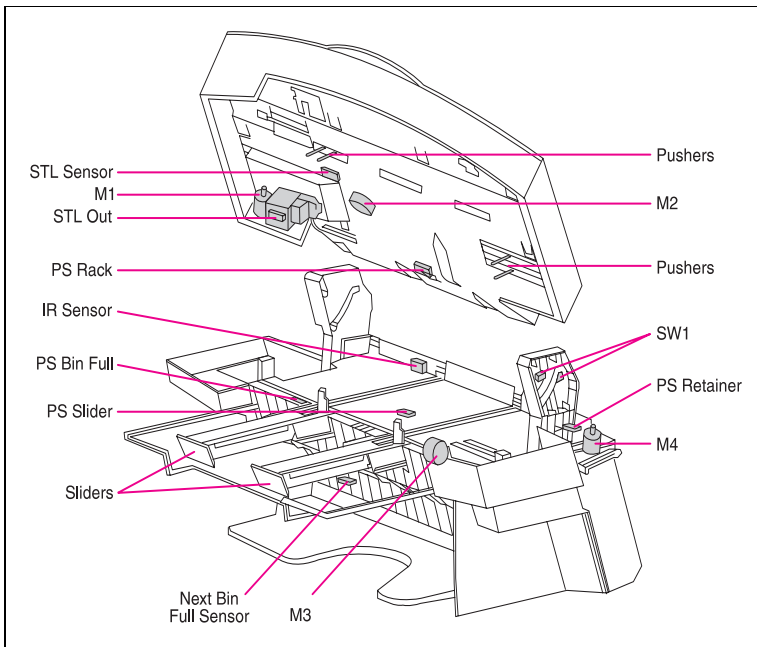

Figure 5-26 Stapler Motors, Sensors, and Switches

Stapler Unit Operation

All communication and control of the mailbox, the 2000-sheet Input Tray, and the stapler unit is through the Paper Handling Controller. These instructions are sent to the stapler controller PCA located in the lower part of the stapler. Power is provided to the stapler by the 8-bin Mailbox/5-bin mailbox with Stapler external 24V DC power supply through the C-link cable. It handles letter and A4 sizes of plain paper. The stapler can staple up to a maximum of 20 sheets.

Table 5-10. Stapler Motors, Sensors, and Switches

Control Device	Title	Location
M1	Stapler DC Motor	Stapler Assembly
M2	Rack Stepper Motor	Top Cover Assembly
M3	Slider Stepper Motor	Top Cover Assembly
M4	Retainer DC Motor	Stapler bed Assembly
IR Sensor	Infra Red Sensor	Stapler bed Assembly
STL Sensor	Stapler Sensor	Stapler Assembly
PSRack	Rack Sensor	Top Cover Assembly
PSSlider	Slider Sensor	Stapler bed Assembly
PSRetainer	Retainer Sensor	Stapler bed Assembly
PSBinFull	Output Bin Full Sensor	Stapler bed Assembly
PSNBinFull	Next Bin Full Sensor	Housing
STLout	Staples Out	Stapler Assembly
SW1	Top Cover Interlock Switches (2 in serial)	Right Hinge

Power-On or Reset Sequence

At power-on or reset, events are performed in the following sequence:

- 1** Stapler Assembly is set to a ready state.
- 2** Retainer Assembly is turned to its initial position.
- 3** Rack Assembly is moved to find its home position, which is in the left side of the Top Cover Assembly.
- 4** Slider Assembly is moved to find its home position, which is inside of the stapler bed.
- 5** Slider Assembly is moved fully out from the stapler bed to the eject position.
- 6** Rack Assembly is moved to activate the Exit Flap Assembly.
- 7** Slider Assembly is moved to its home position.
- 8** Rack Assembly is returned to its home position.

Main Functional Cycles of the Stapler (Internal Paper Path)

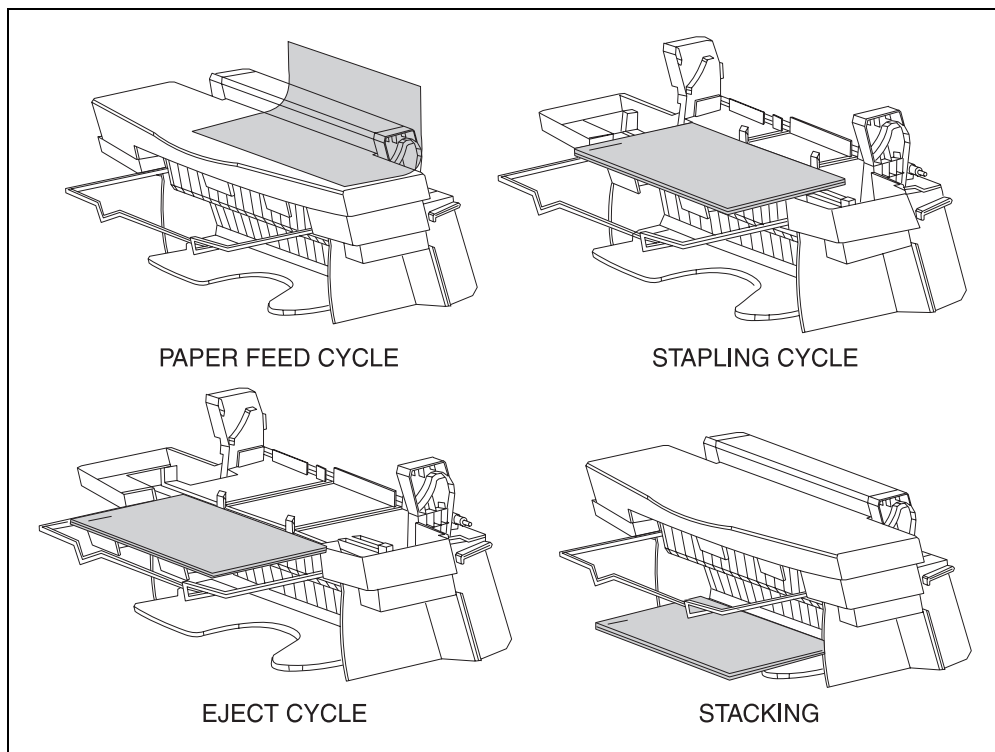

Figure 5-27 Stapler Cycles

Paper Feed Cycle

The stapler bed assembly receives the paper from the 8-bin Mailbox/ 5-bin Mailbox with Stapler Head assembly. The IR Sensor detects when the paper arrives in the stapler. The Retainer (a shaft holding two rubber flexible fingers or anti-curl fingers) rotates once to apply pressure down and backward. This action forces the paper to register against the rear wall of the stapler bed, as well as reduces paper curl. The Registration Pusher (located in the right side of the Top Assembly) registers the paper against the left wall of the stapler bed. This cycle is repeated until the amount of sheets to be stapled is reached (with a maximum of 20).

Stapling Cycle

The Sliders move the stack of sheets to the stapling position. The Registration Pusher applies slight pressure to the stack of sheets toward the left wall of the stapler bed where the stapler is located. Then the stack of sheets is stapled.

Eject Cycle

The stapler bed sliders offset the stacks or jobs. The Off-Set Pusher (located in the left side of the Top Cover Assembly) pushes the stack towards the right side of the stapler bed, whenever it applies. The Sliders move the stack of paper from stapling position to eject position, which is out of the stapler bed (reaching the Wire Frame level). The Wire Frame directs the stack of paper. The Exit Flap Assembly moves down to prevent the job from returning to the stapler bed. The Sliders retract to home position, letting the stack of sheets fall into the output bin. The capacity of the output bin is 350 stapled sheets in jobs of five sheets or equivalent combinations.

Communication Link (Daisy Chain)

Communication Link (C-link) devices include:

- C-link Input Devices:
 - 2000-sheet Input Tray
 - 2 x 500-sheet Input Tray
- C-link Output Devices:
 - 8-bin Mailbox
 - 5-bin Mailbox with Stapler (Includes a Finisher)
 - 7-bin Tabletop Mailbox

Communication and control of the C-link devices is through the paper handling controller mounted on the printer's formatter PCA. The C-link devices (C-link protocol) have their own power supply and controller board that receives signals and commands from the paper handling controller. This communication is illustrated in figure 5-28.

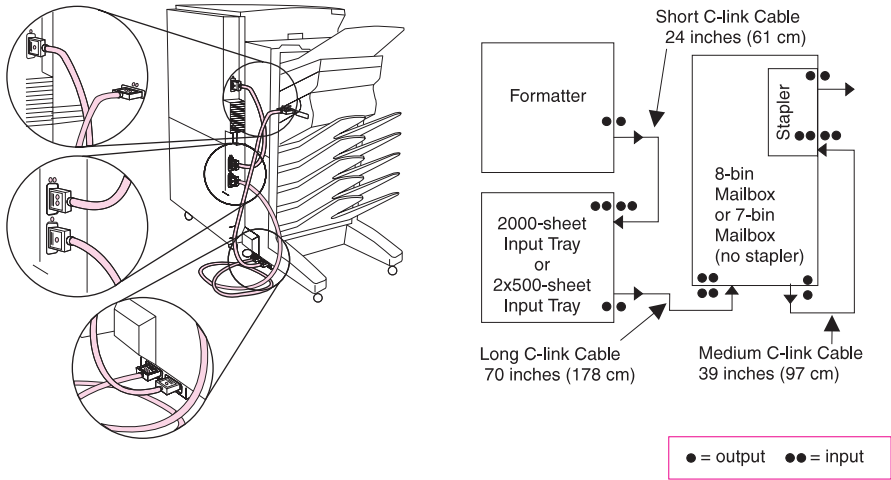

Figure 5-28 Recommended C-link Configuration (Daisy Chain)

Paper Jam Detection

The PIU Sensor (PS2), the Registration Sensor (PS1), the Fuser Delivery Sensor (PS1403), and the Face-down Delivery Sensor (PS1402) detect paper moving through the printer (see figure 5-15 on page 152 and table 5-1 on page 151 for a description of each sensor and illustration of its locations). If a paper jam is detected, the DC Controller immediately stops the printing process and causes a 13.x PAPER JAM message to be displayed on the control panel. If a paper jam occurs in the Envelope Feeder, Duplexer, 2000-sheet Input Tray, 8-bin Mailbox/5-bin Mailbox with Stapler, 2 x 500-sheet Input Tray, or 7-bin Tabletop Mailbox, the 13.x Paper Jam message will indicate the approximate location. See Chapter 7 for more details.

Printer Timing

The Formatter PCA and the DC Controller PCA share information during printer operation. This information consists of printer status, command, and dot-image data. Figure 5-29 shows the general timing of the printer events. Table 5-11 lists the events that take place during normal printer operation.

Table 5-11. Printer Timing

Period	Timing	Purpose
WAIT	From power on to the end of Main Motor initial rotation.	Clear the drum surface potential and clean the Transfer Roller.
STBY (standby)	From the end of the WAIT or the LSTR period until the input of the PRNT signal from the Formatter PCA. Or from the end of the LSTR period to power off.	Maintain the printer in the READY state.
INTR (initial rotation)	From the input of the PRNT signal from the Formatter PCA until the laser diode intensity has been stabilized.	Stabilize the photosensitive drum sensitivity in preparation for printing. Clean the Transfer Roller.
PRNT (print)	From the end of the initial rotation until the Scanner Motor stops.	Form images on the photosensitive drum based on the /VDO signal from the Formatter PCA. Transfer the image to the media.
LSTR (last rotation)	From the primary voltage (DC) off until the Main Motor stops.	Deliver the last sheet of paper and clean the Transfer Roller.
	If another PRNT signal is sent from the Formatter PCA, the printer returns to the INTR period. If not, it returns to the STBY period.	

• Timing chart for two consecutive prints on A4 paper (Lower cassette feed - face-down tray delivery)

Power switch ON

(Unit: Seconds)

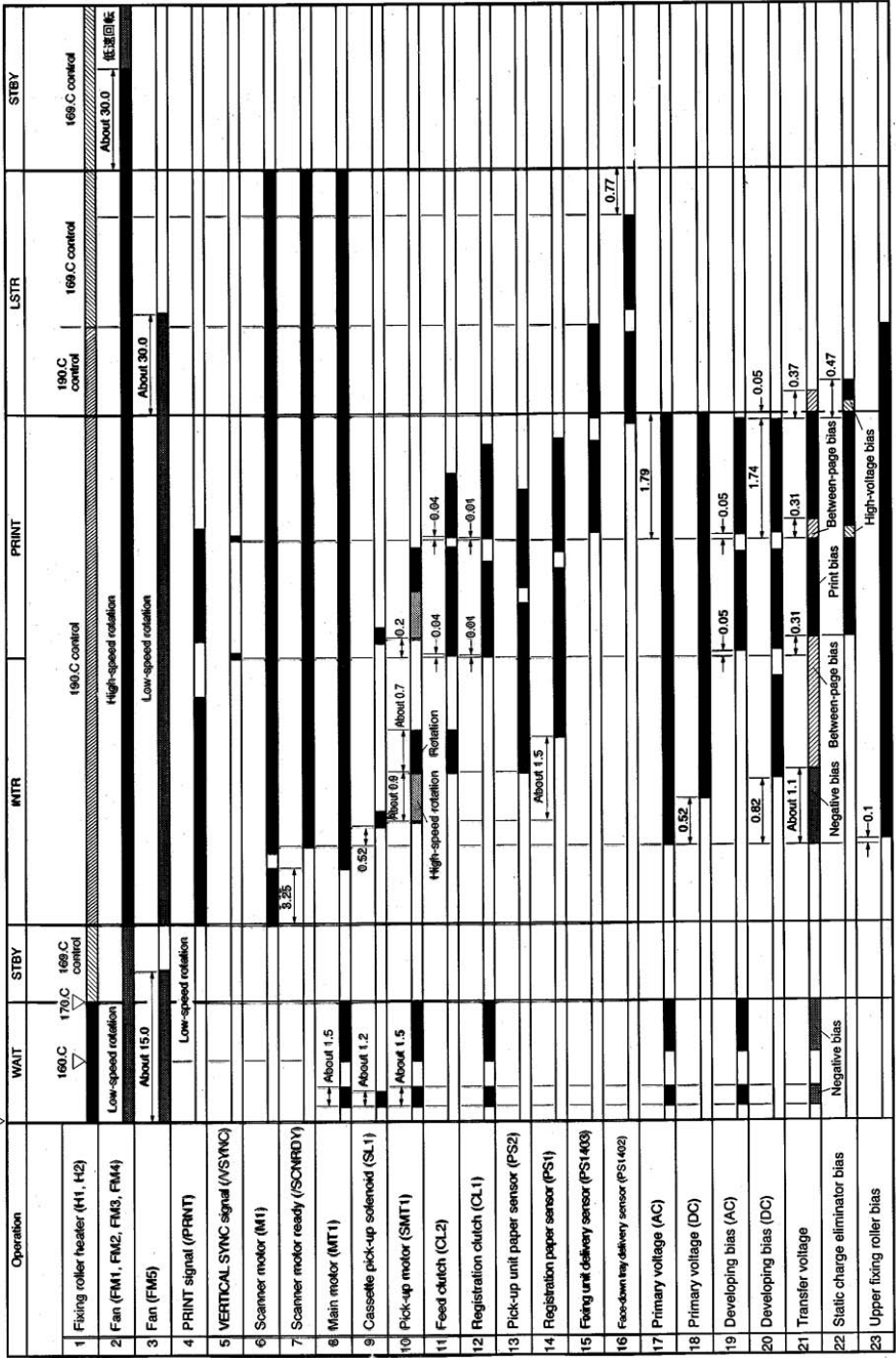

Figure 5-29 General Timing Diagram

IEEE 1284 Parallel Cable Information

This cable is IEEE compliant with A-to-C connectors. To take advantage of its enhanced capabilities such as bidirectional communication between the computer and printer, faster transmission of data, and auto configuration of printer drivers, the customer must have the following:

- Support in software applications for these features.
- A parallel cable with the correct pin configuration (see below).

Parallel Cable Pin Configuration

For best results, use the C2946A (3 meter) or C2947A (10 meter) cable or equivalent.

CAUTION

Ensure that all power and interface cables on the printer and host computer are properly grounded in compliance with local codes.

Table 5-12. Parallel Cable Pin Assignments

Signal Name	Printer Pin Number	Computer Port Number
nSTROBE	15	1
DATA0	6	2
DATA1	7	3
DATA2	8	4
DATA3	9	5
DATA4	10	6
DATA5	11	7
DATA6	12	8
DATA7	13	9
nACKNLG	3	10
BUSY	1	11
CALL (PE)	5	12
SELECT	2	13
NAutoFd	17	14
O VDC (GND)	19-35	18-25
nFAULT	4	15
nSe/In	16	17
nINIT	14	16
PERIPHLH	36	
N.C.	18	

Copy Module Functional Overview

Copy Module System

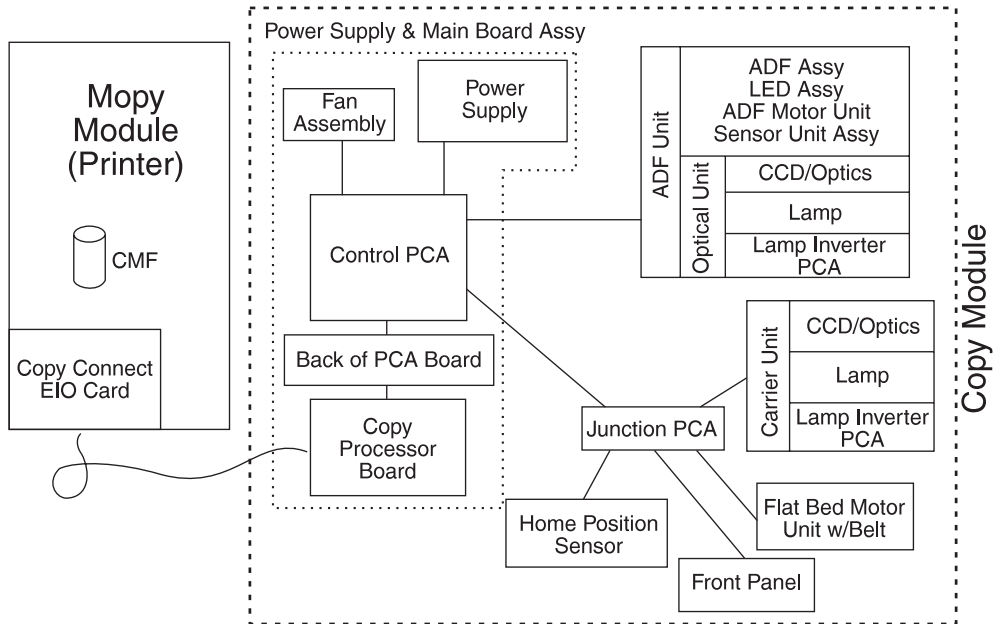

Figure 5-30 Copy Module System Block Diagram

Note The copy module consists of everything inside the large dotted line. The copy engine consists of the copy module minus the Copy Processor Board.

Mopier

- The Mopier's hard disk stores the copy module firmware.
- The Copy Connect Extended Input/Output (EIO) Card functions as a pass-through device.

Copy Module

- Power Supply and Main Board Tray Assembly
 - The Fan Assembly activates while the copy module is turned on. It may run slower if Power Save is on.
 - The Power Supply provides AC to DC power conversion.
 - The Control PCA controls copy module electromechanical functions, imaging system, and errors. It also has an EEPROM which stores the default factory settings particular to each copy module, such as serial number and calibration settings.
 - When you replace the Control PCA, retain the EEPROM from the old PCA and replace it on the new PCA in order to retain the default settings for the HP Digital Copy 320.
 - The Back PCA Board provides a connection between the Copy Processor Board and the Control PCA.
 - The Copy Processor Board is explained on page 187.
- ADF Unit
 - The ADF Assembly provides all mechanics to move paper.
 - The LED Assembly provides feedback from the paper empty sensor to the user. If paper is loaded correctly, the LED is green and a tone sounds.
 - The ADF Motor Unit drives the ADF's paper handling mechanics.
 - The Sensor Unit Assembly has 8 sensors (4 paper width sensors to detect standard paper types; 1 ADF open sensor, and 3 paper-handling sensors).
 - Charge Coupled Device (CCD)/Optics convert reflected light to electronic signals. Also includes mirrors and lenses to point the reflected light.
 - The ADF Lamp illuminates the original document.
 - The Lamp Inverter PCA controls and provides power to the ADF Lamp.

- Carrier Unit (a movable optics system under the flatbed glass, used to copy the front side of ADF jobs and flatbed jobs)
 - Charge Coupled Device (CCD)/Optics convert reflected light to electronic signals. Also includes mirrors and lenses to point the reflected light.
 - The Carrier Unit Lamp illuminates the original document.
 - The Lamp Inverter PCA controls and provides power to the Flatbed Motor Unit with Belt.
 - The Flatbed Motor Unit drives the Carrier Unit back and forth under the flatbed glass.
- Front Panel (LC touch screen and keypad interface)
- Home Position Sensor (detects obstruction of Carrier Unit, a bad Flatbed Motor or Belt)
- Junction PCA (a pass-through connection from the Control PCA to the Carrier Unit, Flatbed Motor Unit, Front Panel, and Home Position Sensor)

Function and Layout of the Copy Processor

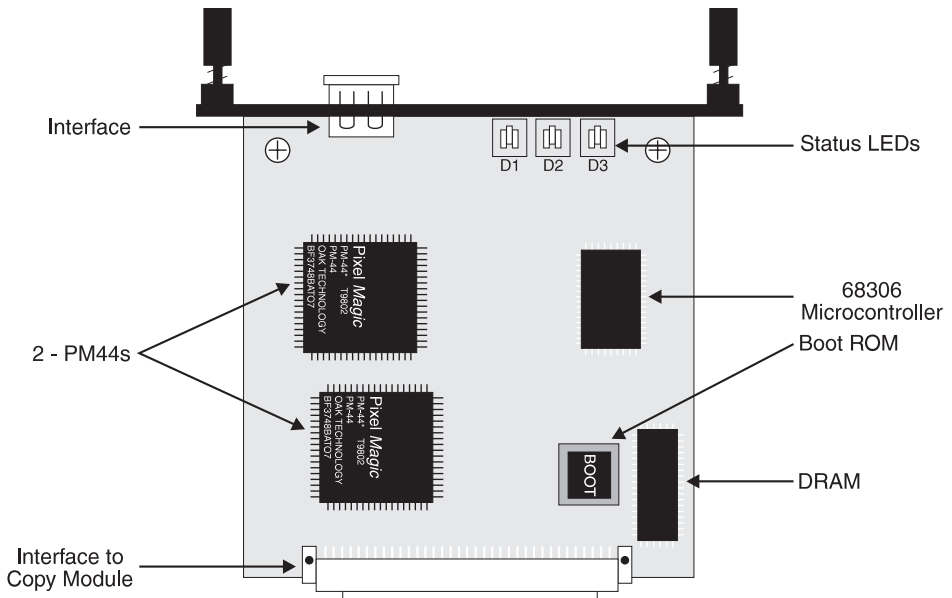

Figure 5-31 Copy Processor and key components

Note The Copy Processor is a replaceable unit.

Functions

- Controls the Front Panel display
- Monitors touch screen inputs
- Controls communication from the copier engine (no unsolicited data flows from the copier engine)
- Performs image processing (grayscale to dithered black and white)
- Initiates and controls communication to the Mopier
 - The interface is IEEE 1394 based, 200 MB per second total bus speed.
 - Copy module firmware is downloaded from the Mopier's hard disk to the Copy Processor.
 - The user inputs settings through the touch screen Front Panel to the Copy Processor to the Mopier.
 - The Mopier sends status responses to the Copy Processor.
 - Mopier control commands go from the Copy Processor to the Mopier.
 - Image data is sent to the Mopier, essentially printer ready strip buffer data.

Key Components

- 2 PM44s [Image processing Digital Signal Processor (DSP)]
- 1 16-bit Motorola 68306 micro-controller
- 1 boot ROM, which provides code to start 1394 communication and begin to download the operating system
- 1 1394 interface and connector
- 1 DRAM

Power Up Process

Copy Processor Board

There are 4 main stages of the power-up process of the Copy Processor. Each of the four stages are represented by an icon displayed on the Digital Copy 320's front panel. If a Digital Copy 320 does not successfully boot up, the icons displayed will assist the field technician in diagnosing the failure.

While first power-up icon is displayed:

- 1 The 16-bit Motorola 68306 microprocessor boots itself from the ROM.
- 2 The Copy Processor performs minimum checks (Level-1 checks) on ROM.
- 3 The Copy Processor polls the keypad for initial key status (to determine whether to start up in Service Mode).
- 4 The Copy Processor begins performing self-checks. (During Level II checks on the Copy Processor, the user can let go of any keys held down. This is a short phase with no animation.)

While second power-up icon is displayed:

- 5 The connection to the HP Mopier 320 starts over the IEEE 1394 interface and looks for the HP Mopier 320. This stage may take more time if the printer is not powered on and ready. If the HP Mopier 320 is not available, the Copy Processor continuously monitors the bus to find one. Therefore, the power-on order between the HP Mopier 320 and the Copy Module does not matter.

While third power-up icon is displayed:

- 6 The unit begins download of the Copy Module Firmware (CMF) from the HP Mopier 320's hard disk to the Copy Processor's DRAM. This may take up to two minutes, although 60-70 seconds is most typical. The hourglass icon is animated during this time and a progress bar is displayed.

While fourth power-up icon is displayed:

- 7 When the download is complete, the unit begins a checksum test on download, initializes the system, and continues to display the icons until it can display the HP Digital Copy 320 Module's main menu.
- 8 Initial key state and Level II failure (if any) are written to the Display Manager and are reported to the Front Panel as Boot Error XXXX. See "Boot Errors" on page 655 for a definition of XXXX.
- 9 The microprocessor jumps to the code in DRAM and never returns to the code in ROM. Then the Copy Module Operating System starts up in Service Mode, if the user was pressing the appropriate keys when power-up began (see Step 3), or the main menu is displayed.

Note

Icons are drawn at the start of the stage. If the stage fails, the icon will be overdrawn with the error icon.

Copy Module

- ▼ The fan comes on.
- ▼ The start button LED lights yellow and then goes off.
- ▼ The Carrier Unit moves to the home position, as detected by the Home Position Sensor. (A grinding noise indicates the shipping lock is in place or an object is blocking the Carrier Unit.)
- ▼ The ADF clears any paper loaded or partially in the paper path.
- ▼ The back light on the Front Panel turns on. (Stopping here indicates that the unit has a bad display or connection. This is particularly true if the Copy Processor is functional.)
- ▼ HP Digital Copy 320 displays on the screen to confirm that the display and connections are good and the Copy Processor is able to boot from ROM.
- ▼ The copy module polls for an HP Mopier 320. If it is not there, the copy module will continuously monitor the bus for one. (The power on order does not matter for the Mopier or copy module.)
- ▼ The four icons and the status bar display.
- ▼ The main menu displays.
- The copy module awaits the start command.

Mopier

- ▼ The Mopier performs startup procedures.

Note

The Scanner Service Agent is part of the copy module firmware that loads from the Mopier's hard disk drive into the Mopier's RAM on power up. When this happens, you see `Loading Program 1` on the front panel of the Mopier. This program runs continuously, instructing the Mopier how to handle requests and information from the copy module.

- ▼ The Mopier loads the Scanner Service Agent from the Mopier hard disk drive. `Loading Program 1` displays on the Mopier's Front Panel. Additional programs may be added later for support of additional functionality.
- The Scanner Service Agent checks the printer's product ID field to see if the printer is an HP Mopier 320. If it is not, the Scanner Service Agent will ignore requests from the copy module. `Loading Program 1` will still display on the printer's Front Panel, but the program remains dormant. See "Notes About the HP Mopier 320 Product ID" below.

Note

The units must be power cycled once the copy module firmware is installed. The copy module firmware will not work with any printer other than an HP Mopier 320.

Notes About the HP Mopier 320 Product ID

The product ID for the Mopier 320 is stored in NVRAM. If NVRAM fails or the formatter is replaced, the product ID is not lost because it is backed up on the printer's hard disk drive, beneath the FAT so that it is not lost if the disk is initialized. In the case of a hard disk failure and subsequent replacement, the product ID will be backed up again to the new hard disk.

CAUTION

Do not replace the Mopier's hard disk drive and Formatter at the same time. Doing so will cause the printer's product ID to revert to the HP LaserJet 8100, causing the Scanner Service Agent to be dormant, which in turn will cause the HP Digital Copy 320 to not boot up.

In the unlikely event that an HP Mopier 320 reverts to a LaserJet 8100 (confirmed by printing a configuration page), contact HP support for assistance to reprogram the printer's product ID.

Another reason not to replace the hard disk drive and Formatter at the same time is the loss of page counting.

ADF Simplex Operation

- ▼ The user inputs commands (through the touch screen and buttons) which are then sent to the Copy Processor Board.
- ▼ The Copy Processor displays the appropriate screens on the copy module's LCD based on the user's inputs. The screens displayed are based on the screens downloaded from the Mopier.
- ▼ The user presses the **START** button and the copy module receives the ADF read command. (The ADF or flatbed is determined by the ADF paper loaded sensor.)
- ▼ The bottom document placed face-down in the chute is fed through the ADF. Paper size is detected by the Paper Size Sensor (A3, A4, B4, B5). This will tell the ADF Motor when to stop.
- ▼ The Carrier Unit reads the white reference and then moves to the ADF read position.
- ▼ The ADF Motor starts to feed the paper. The top sensor detects the edge of the page.
- ▼ The copy module counts the number of motor pulses to reach the end of the page. It also determines mispicks, double or misfeeds, and end of page when the data ends.
- ▼ The image is scanned by the copy module engine, as explained on page 196.
- ▼ The page is stacked in the output tray. This process repeats until the chute is empty.
- The ADF Motor stops and the copy module awaits the next command.

ADF Duplex Operation

- ▼ The user inputs the duplex command from the touch screen on the Front Panel.
- ▼ Frontside data is the same as simplex operation.
- ▼ Both the backside and frontside are copied simultaneously by two Charge Coupled Device (CCD) arrays on the HP Digital Copy 320. (A Charge Coupled Device is a miniature photometer that measures light and converts the measured value to analog voltage.)
- ▼ Backside data is copied and stored into the backside image buffer residing on the copy engine.
- After the frontside buffer has been sent to the Copy Processor, the data stored in the backside buffer is then sent to the Copy Processor.

Flatbed Operation

- ▼ The user inputs commands (through the touch screen and buttons) which are then sent to the Copy Processor Board.
- ▼ The Copy Processor displays the appropriate screens on the copy module's LCD based on the user's inputs. The screens displayed are based on the screens downloaded from the Mopier.
- ▼ The user presses the **START** button and the copy module looks for paper loaded in the ADF. If no paper is found, the copy module receives the flatbed read command.

Note

The user interface is identical from ADF copy to flatbed copy.

- ▼ The Carrier Unit reads the white reference and then moves to the right to read from the flatbed glass and proceeds in steps for user specific paper length.
- ▼ The copy engine scans the image (see page 196).
- The Carrier Unit returns to the home position and the HP Digital Copy 320 awaits the next command.

Checks Executed when the Start Button is Pressed

- Paper jam
- ADF open
- Lamp intensity
- Lamp fuse
- Motor fuse
- Detect paper loaded (on ADF)

Image Path

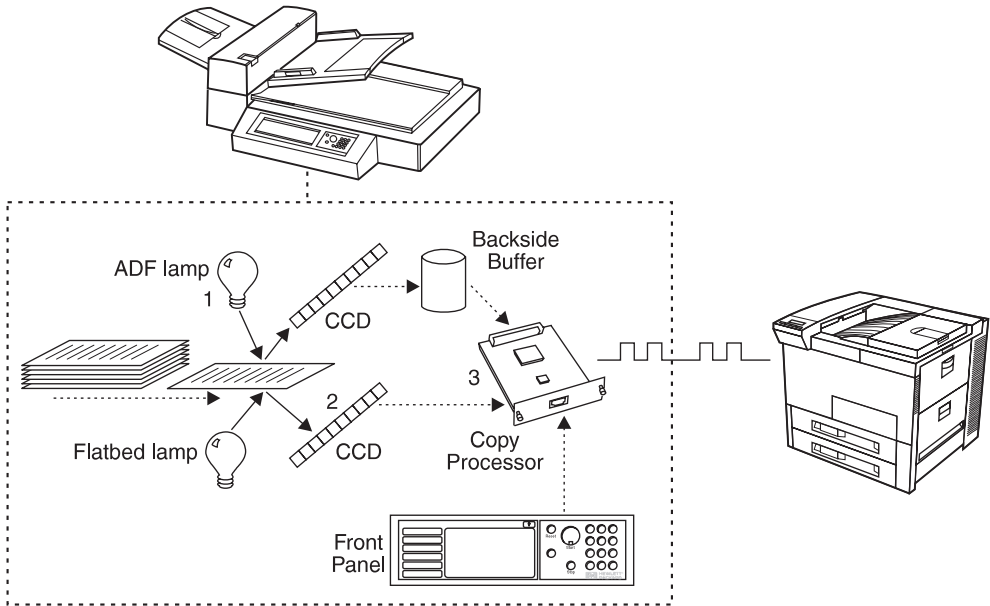

Figure 5-32 Image path (1 of 2)

Step 1: The light source illuminates a horizontal strip of the image called the raster line.

Step 2: Reflected light is gathered and guided by lenses and a series of mirrors and is then captured by a 4864 pixel element Charge Coupled Device (CCD) array. The CCD converts analog voltages into raw digital grayscale information.

Step 3: Raw digital image data is sent from the copy module's CCD to PM-44s. The PM-44s convert raw digital information into a Mopier ready bit stream, dithered black and white with layouts such as N-up, duplex, staple, and so forth, and sends it to the Mopier via the 1394 cable. Data format is strip buffer raster data. The copy module firmware on the Mopier adds Printer Job Language (PJL) control commands later.

Repeat: One horizontal line or raster line of the image is captured in a step and the Carrier Unit or ADF mechanically moves to the next step. The distance moved determines the subscan sampling rate (1/300 inch = 300 ppi, 1/600 = 600 ppi).

Note

Pages load face down on the ADF. The backside optics are in the ADF above the frontside optics, which are in the Carrier Unit, below the glass.

Communication to the Mopier

Note

The Copy Connect EIO is essentially a pass through device.

- ▼ Data is handed from the Copy Connect EIO to the Scanner Service Agent (SSA), which is part of the copy module firmware that runs in the Mopier's RAM and shows `Loading Program 1` on the Mopier's Front Panel when loaded successfully.
- ▼ The copy module firmware adds several Printer Job Language (PJM) control codes to set resolution, printer language and page layout.
- The data stream goes around the Mopier's normal image processing system directly into page memory. This allows for the high speed at which copied pages can be printed.

Communication Channels

- Image data: high speed uni-directional 1394 channel
- All other communications: bidirectional 1394 channel

Print Job Interrupt

There are two levels at which a user can interrupt a network print job to make a copy on the copy module:

- Low priority - when you place a document in the ADF or touch any of the buttons on the copy module, all incoming network jobs are held until the copy module is finished copying.
- High priority - Select **JOB INTERRUPT** on the touch screen. The current copy job is interrupted at the copy boundary. For instance, if the Mopier is printing copy 3 of 5, it will finish copy 3 and hold copies 4 and 5 until the copy module is finished copying.

Paper Path and Sensors

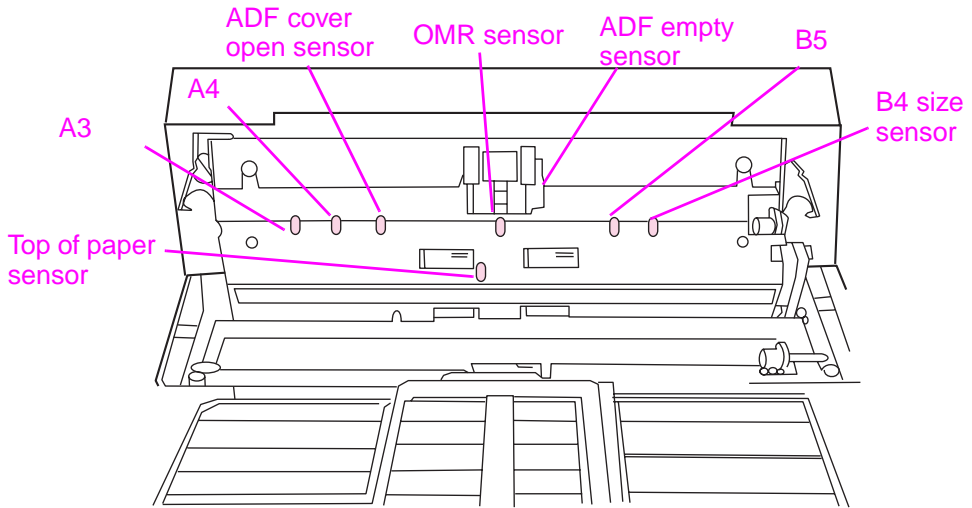

Figure 5-33 Locations of ADF Sensors

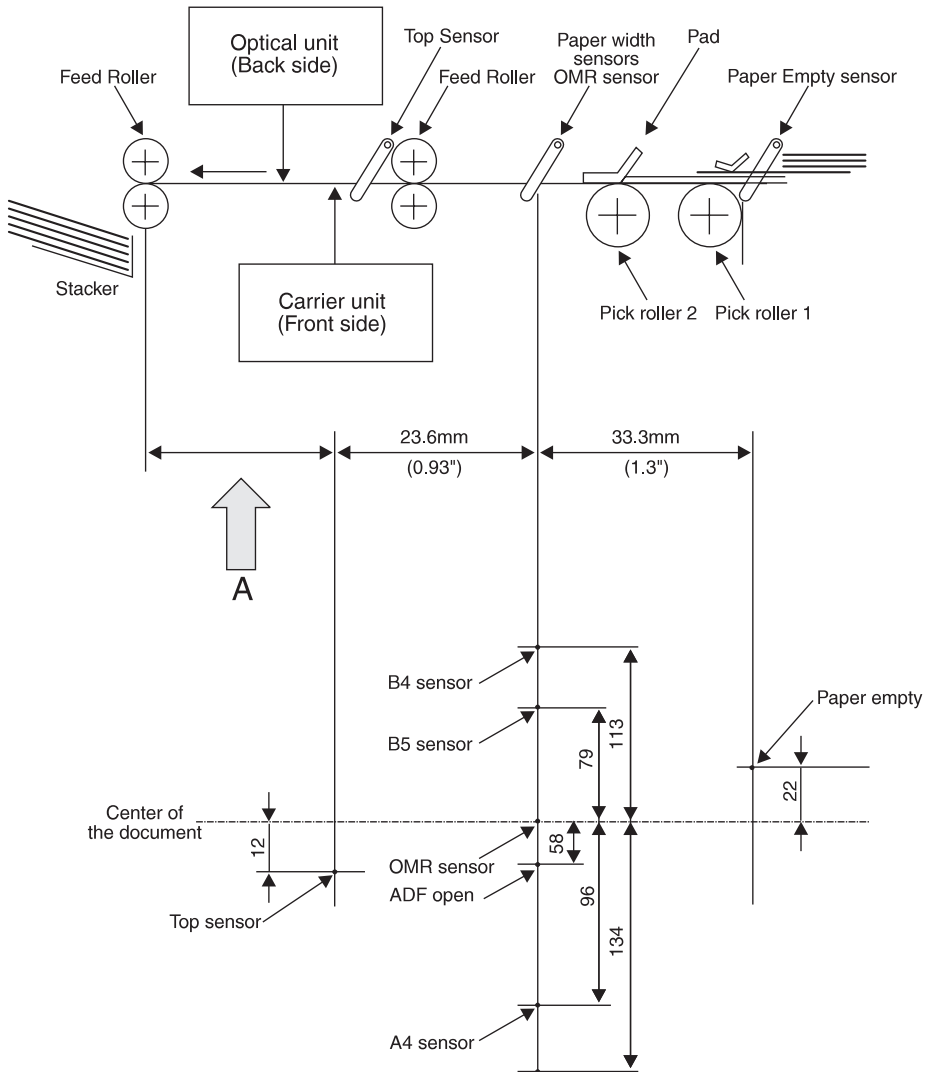

Figure 5-34 ADF Sensors functional diagram

6 Removal and Replacement

Chapter contents

Removal and Replacement Strategy - - - - -	202
Required Tools- - - - -	203
User Installable Accessories - - - - -	204
Hardware Table - - - - -	212
HP Mopier 320	
Engine Removal and Replacement - - - - -	214
2000-sheet Input Tray Removal and Replacement - - - -	285
2 x 500-sheet Input Tray Removal and Replacement - - -	314
7-bin Tabletop Mailbox Removal and Replacement - - - -	347
8-bin Mailbox Removal and Replacement- - - - -	384
Stapler Assembly Removal and Replacement- - - - -	416
HP Digital Copy 320	
HP Digital Copy 320 Removal and Replacement - - - - -	429
Installing the HP Digital Copy 320 - - - - -	430
Copy Module Maintenance Parts - - - - -	440
Copy Module Skins - - - - -	445
Copy Module Power Supply/Main Board Assemblies - - -	464
Copy Module ADF Unit Assemblies- - - - -	475
Copy Module Flatbed Assemblies - - - - -	488

Removal and Replacement Strategy

This chapter documents the removal and replacement of major assemblies.

Replacement is generally the reverse of removal. Occasionally, directions for difficult or critical replacement procedures are included.

WARNING!

Unplug the power cord from the power outlet before attempting to service the printer. If this warning is not followed, severe injury may result.

Never operate or service the printer with the protective cover removed from the Laser/Scanner assembly. The reflected beam, although invisible, can damage your eyes.

This printer has some sharp sheet metal edges that can cause injury.

Electrostatic Discharge (ESD) Precautions

CAUTION



The printer and accessories contain parts that are sensitive to ESD. Always service printers at an ESD-protected workstation or wear an anti-static wrist wrap. Watch for the ESD reminder symbol on illustrations.

Required Tools

- #2 magnetized Phillips screwdriver (6-inch shaft)
- Small flat-blade screwdriver
- Small pair needle-nose pliers
- T-10, T-15, and T-20 Torx driver (6-inch shaft)

All components in the printer, the 2000-sheet Input Tray, 7-bin Tabletop Mailbox, and the 2 x 500-sheet Input Tray use Phillips head screws that require a #2 size Phillips screwdriver. Make sure to use a Phillips screwdriver and not a Posidriv screwdriver. Figure 6-1 shows the difference between a Phillips and a Posidriv screwdriver. Note that the Phillips tip has more beveled surfaces.

All screws used in the field-replaceable units of the 8-bin Mailbox and the 5-bin Mailbox with Stapler components require a T-10, T-15 or T-20 Torx driver.

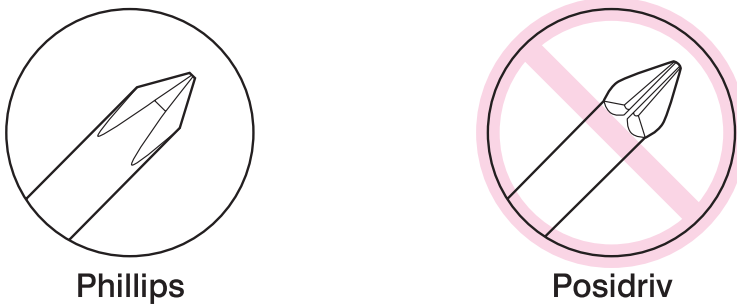

Figure 6-1 Phillips vs. Posidriv Screwdrivers

Note

See table 6-1 on page 212 and Chapter 8 for a list of the screws and other common hardware used in the printer.

CAUTION

To install a self-tapping screw, first turn it counter-clockwise to align it with the existing thread pattern, then carefully turn clockwise to tighten. Do not over-tighten. If a self-tapping screw-hold becomes stripped, repair of the screw-hole or replacement of the affected assembly is required.

User Installable Accessories

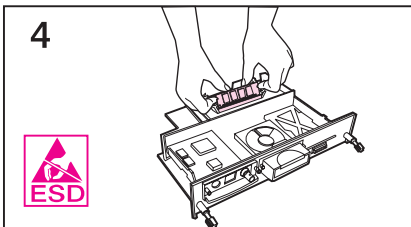
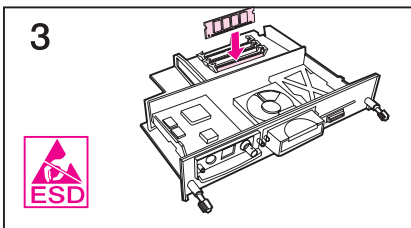
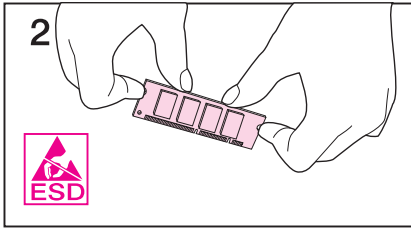
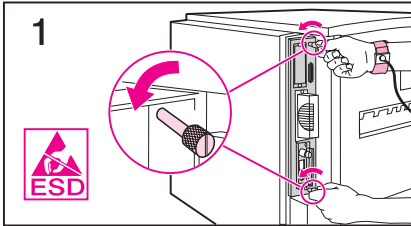

Memory and Personality Upgrade

CAUTION

DIMMs and the Formatter PCA can be damaged by small amounts of electrostatic discharge (ESD). Wear an anti-static wrist wrap.

Print a configuration page (page 589).

- 1 Turn the printer off. Unplug the power cord, and disconnect any cables.

Loosen the two captive thumb screws on the back of the printer. Grasp the screws and pull the formatter board out of the printer. Place it on a flat, non-conductive surface.

- 2 Remove the DIMM from the antistatic package. Hold the DIMM with fingers against the side edges and thumbs against the back edge. Align the notches on the DIMM with the DIMM slot. (Check that the locks on each side of the DIMM slot are open, or outward.)
- 3 Press the DIMM straight into the slot (press firmly).
- 4 Make sure the locks on each side of the DIMM snap inward into place. (To remove a DIMM, the locks must be released.)

Slide the formatter board back into the printer, and tighten the two screws. Plug in the power cord and connect all cables. Turn the printer on.

Disk Drive

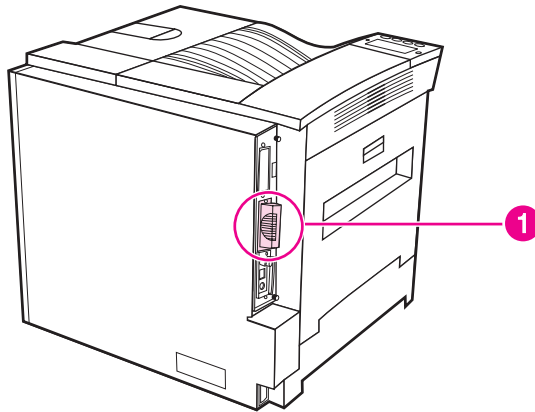

Figure 6-2 Disk Drive

To remove the disk drive:

- 1 Turn the printer off, and unplug it.
- 2 Loosen the 2 captive screws, and remove the disk drive from slot #2 (figure 6-2, callout 1).

To reinstall the disk drive:

- 1 Turn the printer off.
- 2 Install the disk drive in slot #2 (figure 6-2, callout 1), and tighten the 2 captive screws.
- 3 Print a configuration page to verify the settings.

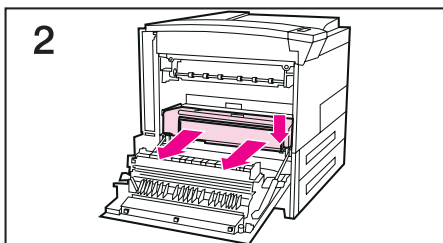
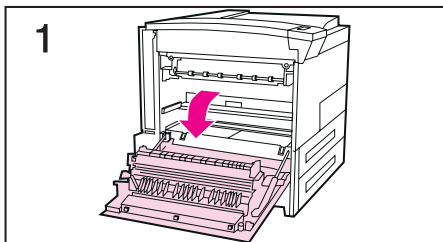

Duplexer

- 1 With the printer turned off and unplugged, open the Diverter door on the left side of the printer.
- 2 Push down the green release lever located at the lower right of the Duplexer and slide it straight out of the printer.

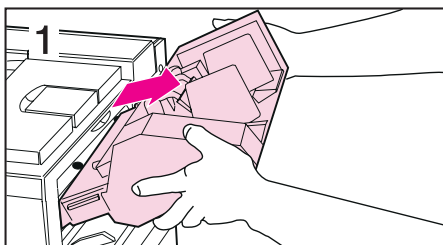

Envelope Feeder

- 1 With the printer turned off and unplugged, slide the Envelope Feeder up and out of the printer.

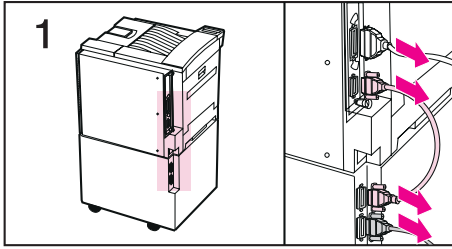

2000-sheet or 2 x 500-sheet Input Tray

- 1 With the printer turned off and the power cable unplugged, disconnect all C-link cables from the Formatter Assembly and from the input device.

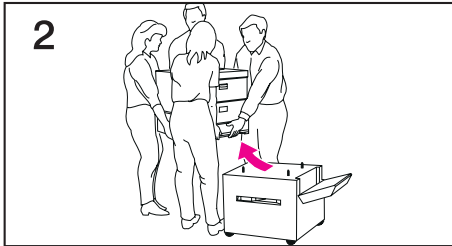

WARNING!

The printer weighs approximately 106 pounds (48 kg). Use four people to lift it.

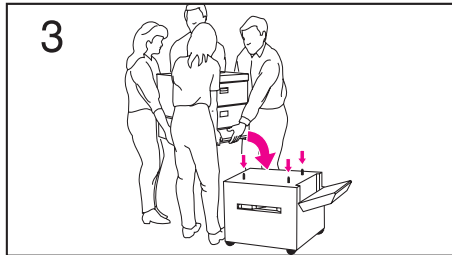

- 2 Lift the printer off of the Tray 4 assembly and place it on a smooth, sturdy surface.

To Reinstall:

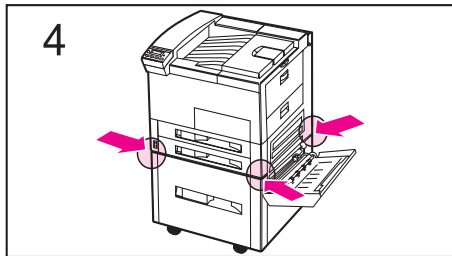

- 3 Match the locator pins as illustrated in step 3.
- 4 Make sure that the printer is aligned on all corners.
- 5 Reconnect all power and C-link cables.

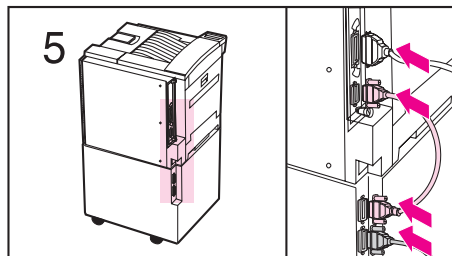

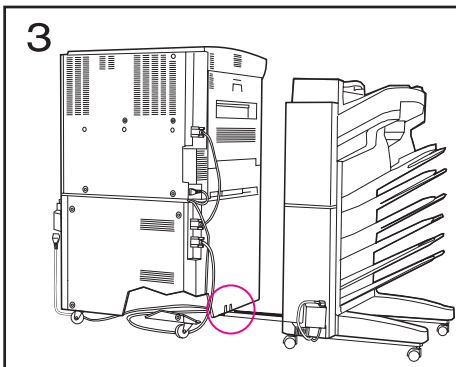
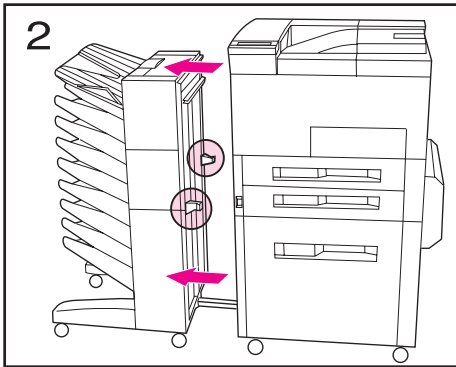
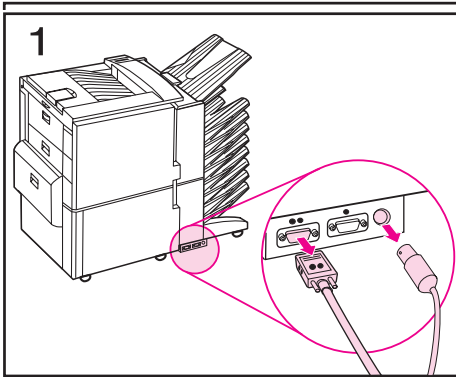

8-bin Mailbox/5-bin Mailbox with Stapler

- 1 With the printer turned off and unplugged, disconnect the power cable and C-link cable from the input device and power box.
- 2 Carefully slide the 8-bin Mailbox/5-bin Mailbox with Stapler away from the printer until the locator tabs and the lower guide rail are clear. See Figure 2.
- 3 Press in the green tabs and remove the bracket installed underneath the input device. See Figure 3.

To Reinstall:

- 1 Reinstall bracket underneath input device. Reinstall C-link and power cables. See Figure 1.

Note

Attach and secure the C-link cable to the lower connector on the input device.

Route the mailbox's power cord beneath the printer to the transfer-door side of the printer and connect it to the bottom of the powerbox.

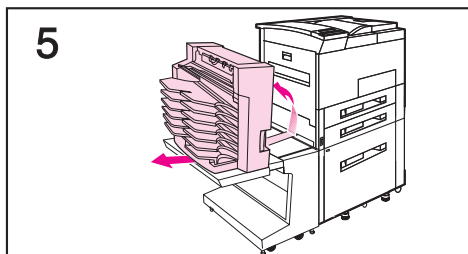
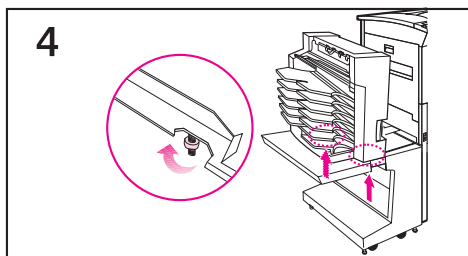
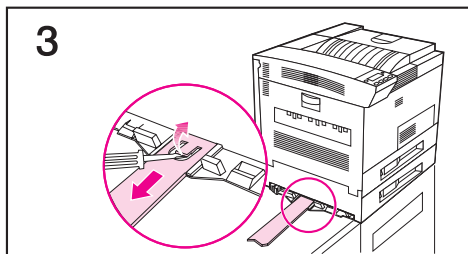
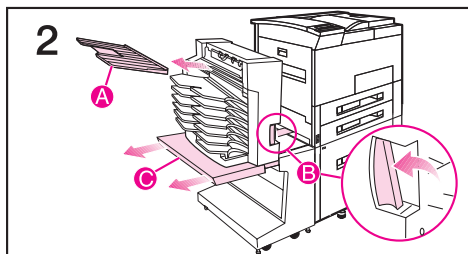
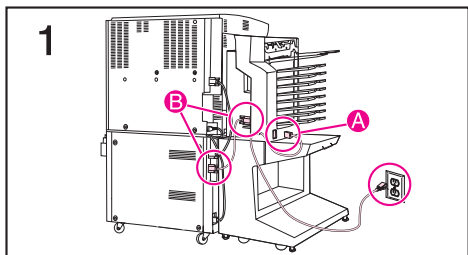

7-bin Tabletop Mailbox

- 1 With the printer turned off and unplugged (A), disconnect the C-link cable from the top and bottom (B) connectors.
- 2 Remove the Face-up Bin (A) from the top slot of the mailbox. Depress the handle mechanism on the front of the mailbox (B). Pull the mailbox away from the printer until the tray is fully extended (C).
- 3 Release the plastic alignment guide from the latching mechanism.
- 4 Remove the wingnuts from the studs beneath the tray extension on the stand.
- 5 Slide the mailbox away from the printer. Raise the alignment guide and tape it in place before moving the mailbox.

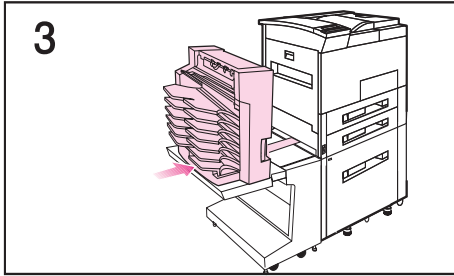
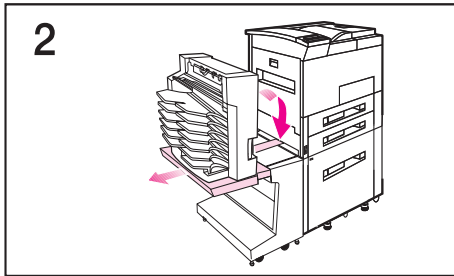
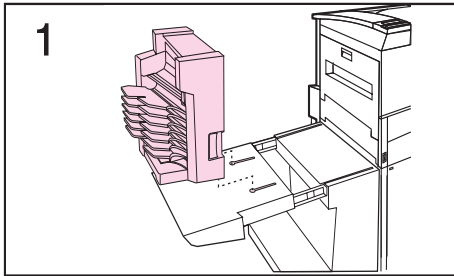

To Reinstall:

- 1 Place the mailbox onto the stand by aligning the threaded studs on the connector plate with the two holes on the top of the stand.
- 2 With the tray on the stand fully extended, lower the alignment guide onto the locking mechanism.
- 3 Slide the mailbox toward the printer.

Note

Use your thumbs to do this and keep the tray on the stand fully extended.

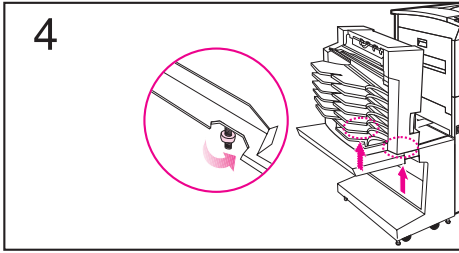

4 Secure the mailbox to the stand by tightening the thumb fastener onto the studs beneath the tray extension on the stand.

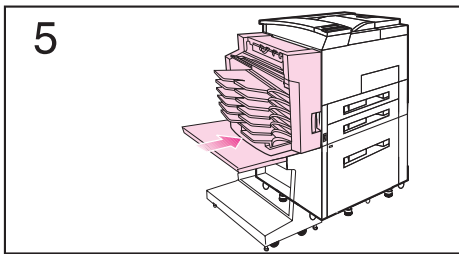

5 Push the mailbox toward the printer until it snaps in place.

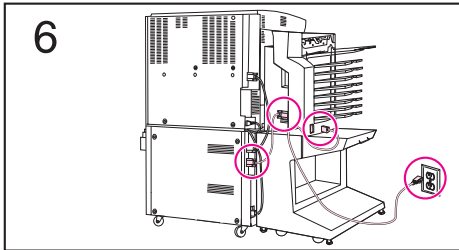

6 Connect the C-Link cable. Plug the power cord into the mailbox and an AC power outlet.

Hardware Table

Note

The screws listed in table 6-1 are also listed in Chapter 8 with their respective assemblies.

Table 6-1. Hardware Table



Example	Reference	Description	Part Number	Usage
	CH101 and CH102	Screw, w/washer, M3x8	XA9-0872-000CN	General, Metal to metal
	CH103	Screw, M4X8	XB6-7400-807CN	Main Motor
	CH104	Screw, CT, M3X3	XB5-6303-007CN	Fan 1, Fan 2
	CH105	Screw, w/washer, M3X20	XA9-0817-000CN	Laser/Scanner
	CH106	Screw, tapping, truss head, M3X8	XB4-7401-809CN	HVPS, DC Controller
	CH107	Screw, tapping, pan head, M4X10	XB4-7401-009CN	Diverter Assembly, Face-up Solenoid Assembly

Table 6-1. Hardware Table (continued)

Example	Reference	Description	Part Number	Usage
	Kit 1	Complete hardware screw kit for 2000-sheet Input Tray	RY7-5044-000CN	2000-sheet Input Tray, general use
	Kit 3	Complete hardware screw kit for Mailbox	C4785-60521	8-bin Mailbox/5-bin Mailbox with Stapler, Elevator Head

Engine Removal and Replacement

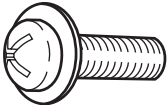
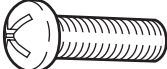
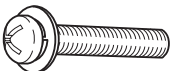
Control Panel-	215
Covers -	217
Delivery Unit (for Face-down Bin) -	226
Diverter Assembly -	229
Diverter Door Assembly -	230
Lower Right Door Assembly -	231
Fan 1, Laser/Scanner and Housing (Exhaust) -	234
Fan 2, Low Voltage Power Supply (Exhaust)-	236
Fan 3, Formatter Fan and Housing (Intake) -	237
Fan 4, Delivery Unit (Exhaust) -	238
Fan 5, Tray 1 (Intake) -	239
Tray 1 -	241
Tray 1 Pickup Assembly-	244
Feeder Assembly- -	248
Formatter Assembly -	250
Fusing Assembly -	252
Laser/Scanner Assembly -	254
Main Gear Assembly -	256
Main Motor Assembly-	259
Paper Input Unit (PIU) -	260
PCA, DC Controller-	261
Output Paper Sensor PCA -	262
High Voltage Power Supply (HVPS)-	269
Low Voltage Power Supply (LVPS) -	270
Registration Assembly -	271
Tray 1 Feed Roller and Separation Pad -	274
Tray 2 and 3 Pickup, Feed, and Separation Rollers -	276
Paper Input Unit Sensor (PS2) -	277
Registration Sensor (PS1) -	279
Face-up Solenoid Assembly (SL3) -	281
Transfer Roller Assembly -	282
Tray 2 and 3 Assemblies -	284

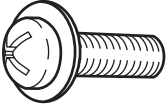
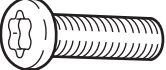
Control Panel

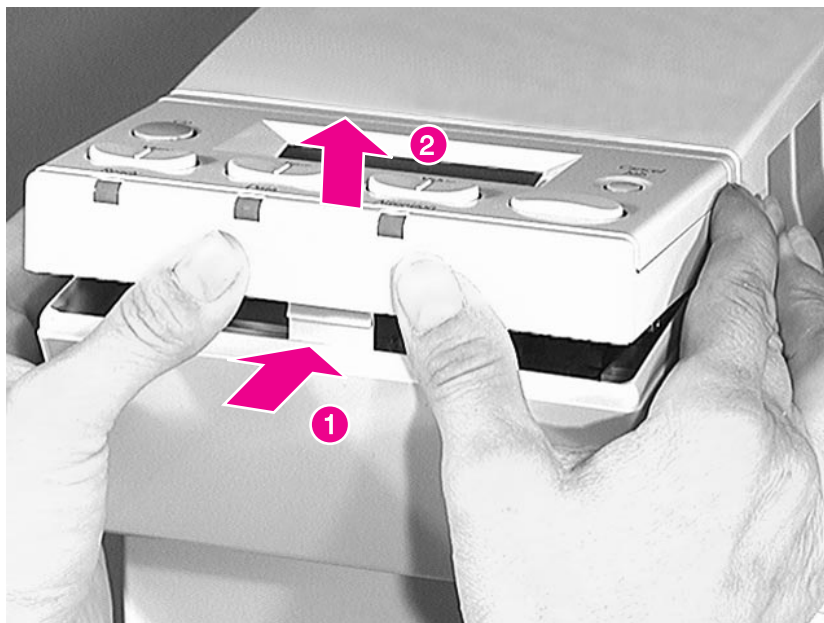

Figure 6-3 Control Panel (1 of 2)

- 1 While pushing in on the center area (figure 6-3, callout), lift up on the forward edge of the control panel to release the plastic retaining tab.

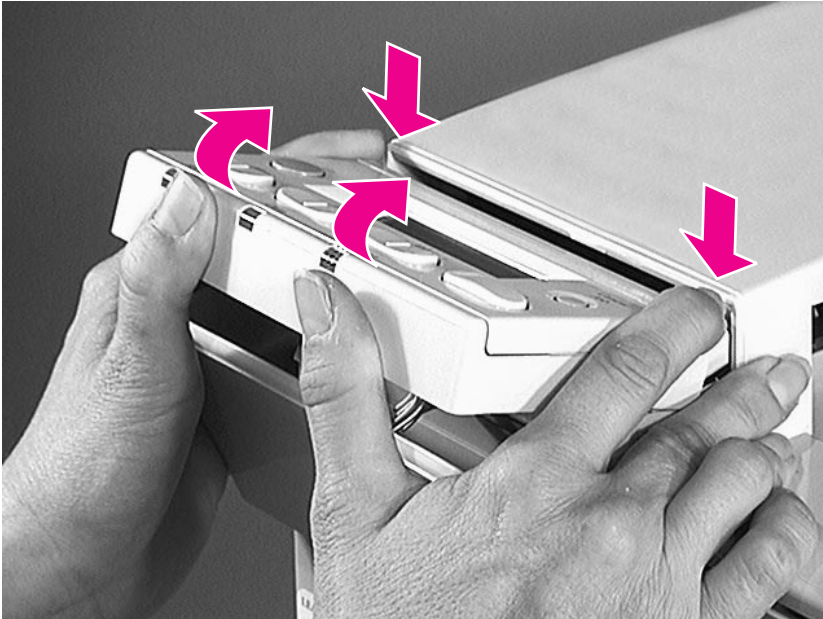

Figure 6-4 Control Panel (2 of 2)

- 2 Press down on the back while pushing up on the front of the Control Panel to free it from the chassis.

To Reinstall:

Plug in the cable, replace the cable in its retainer, insert the rear edge of the control panel under the top cover lip, and press down on the forward edge to snap it into place.

Covers

There are five cover assemblies in this printer:

- AC Access Cover, located at the left rear of the printer.
- Back Cover, provides access to the High Voltage Power Supply, DC Controller, Low Voltage Power Supply, and Main Motor.
- Front Cover, including front access door.
- Left Lower Cover, located below the Diverter Access Door.
- Top Cover, provides access to the Face-down Delivery Unit and Laser/Scanner Assembly.

AC Access Cover

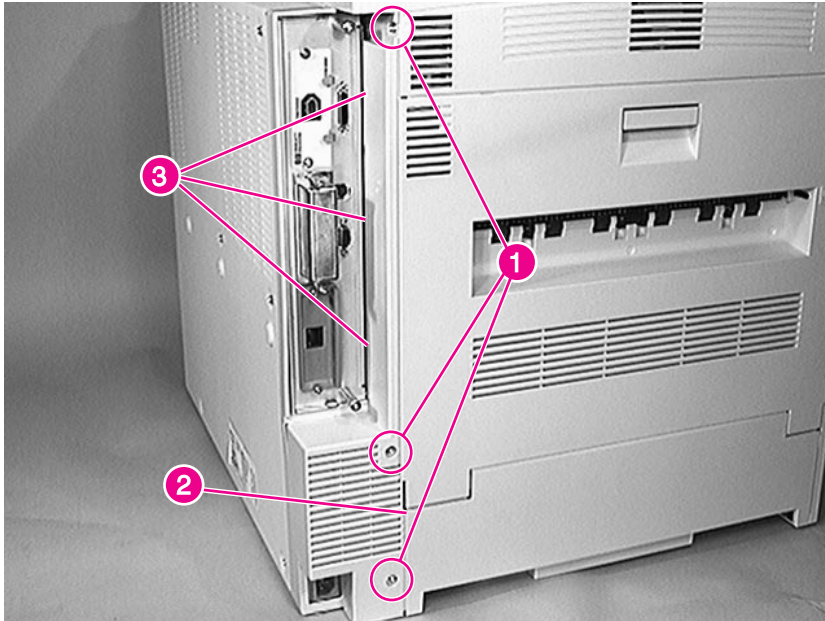

Figure 6-5 AC Access Cover

- 1 Remove the Formatter PCA.
- 2 Remove 3 screws (figure 6-5, callout 1).

To Reinstall:

- 1 Insert the panel edge (figure 6-5, callout 2) inside the back cover (if installed).
- 2 Be sure to insert the three alignment tabs (figure 6-5, callout 3) into their slots before replacing the screws.

Back Cover

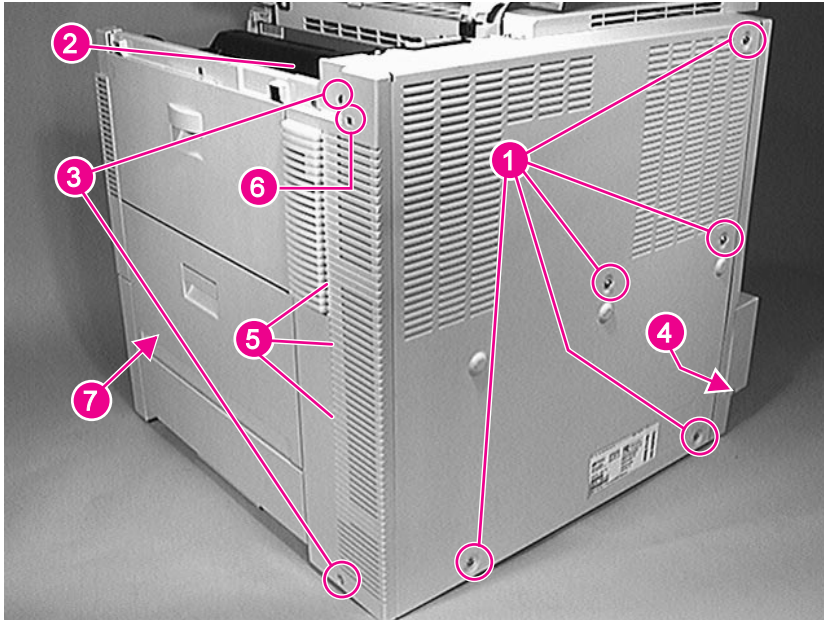

Figure 6-6 Back Cover

Note

Remove the metal back cover and the plastic panel at the right rear as a single unit. The square opening at the upper rear corner on the right-side plastic panel is the engine test access (callout 6).

- 1 Remove 5 screws (figure 6-6, callout 1).
- 2 Open the top cover door, and remove 1 screw (figure 6-6, callout 2).
- 3 Open the 2000-sheet Input Tray transfer door (if installed), Tray 1, and the Right Lower Door Assembly (callout 7).
- 4 Remove 2 screws (figure 6-6, callout 3) from the plastic panel to the left of the metal back cover.
- 5 Carefully release the cover around the AC input connector (figure 6-6, callout 4) at the lower right of the back cover, and slide the right side of the cover slightly forward.
- 6 Carefully release the retaining tabs (figure 6-6, callout 5) on the plastic panel to the left of the metal back cover by gently pulling the cover to the left while moving both pieces away from the printer chassis.

Front Cover

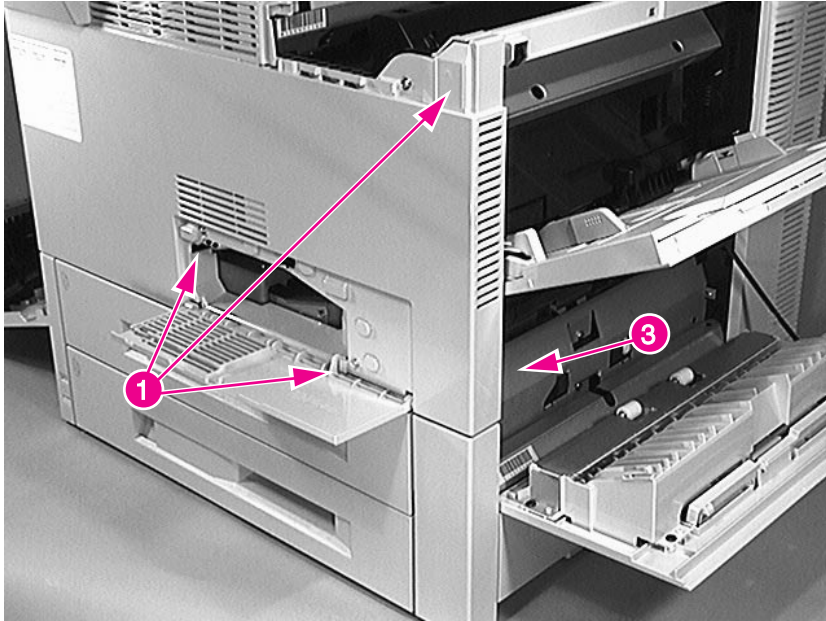

Figure 6-7 Front Cover (1 of 2)

- 1 Open all access doors and remove the Duplexer if installed.
- 2 Open the front access door, and remove 3 screws (figure 6-7, callout 1).

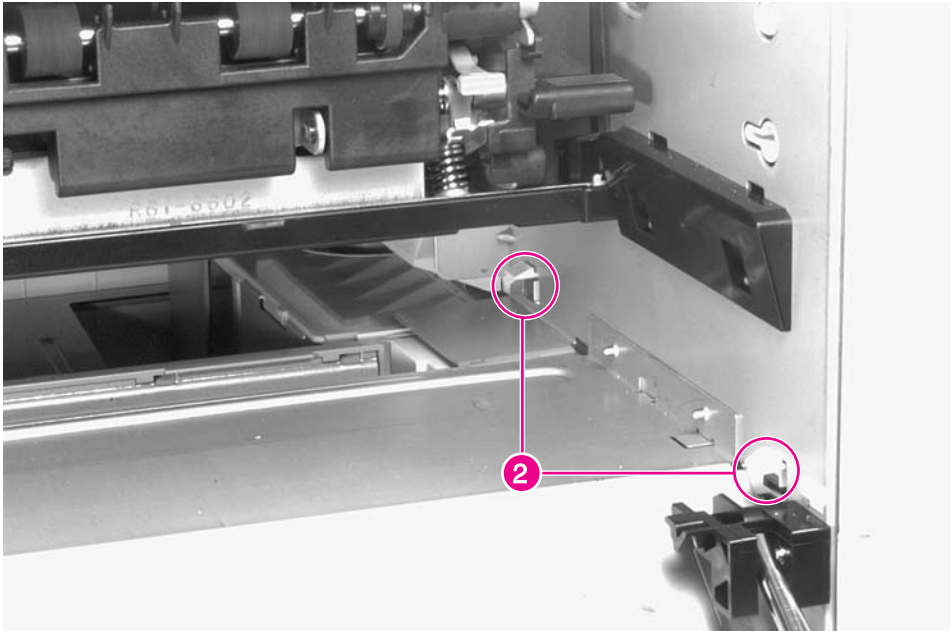

Figure 6-8 Front Cover (2 of 2)

- 3 Open the Diverter Access Door and release the two plastic retaining tabs inside the Duplexer cavity (figure 6-8, callout 2).

CAUTION

Be careful; the plastic upper retaining tabs will break off if the cover is tilted too far out.

- 4 Carefully pull the bottom of the cover away from the chassis while moving it to the right to release the retaining tab (figure 6-7, callout 3).
- 5 Carefully tilt the bottom edge of the cover away from the chassis to release the upper retaining tabs.

Left Lower Cover

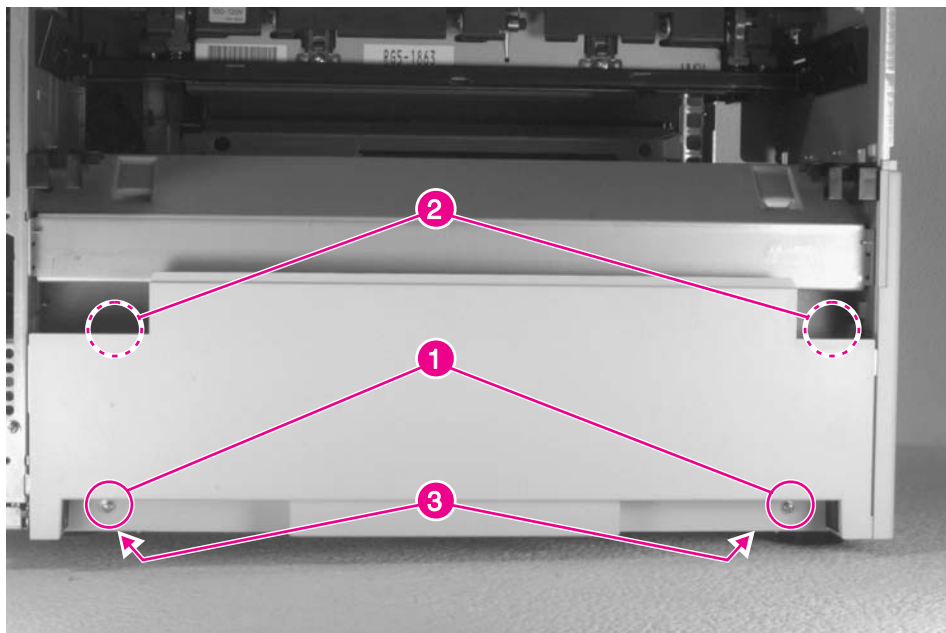

Figure 6-9 Left Lower Cover

CAUTION

Be careful not to damage the plastic guides on the inside of the lower left cover. They are part of the Duplexer paper path.

- 1 Remove the Diverter Assembly access door (see figure 6-15).
- 2 Remove 2 screws (figure 6-9, callout 1).
- 3 Press down firmly on the top cover outer ends to release the retaining tabs on the inside of the cover (figure 6-9, callout 2) and the retaining tabs at the lower edge of the cover (figure 6-9, callout 3).
- 4 Pull the cover away from the chassis, left side first.

To Reinstall:

- 1 Relocate the right side of the cover behind the plastic edge piece first.
- 2 Slide the cover toward the chassis and insert the two retaining tabs into position. Lift up to snap the cover into place.

Top Cover

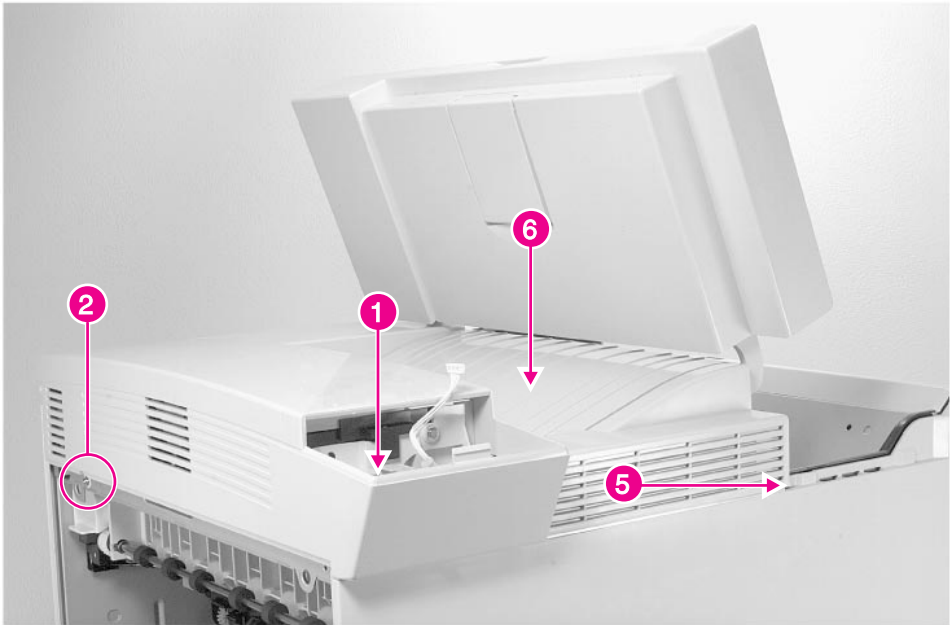

Figure 6-10 Top Cover (1 of 2)

- 1 Remove the Control Panel (see figure 6-3 on page 215), then remove 1 screw (figure 6-10, callout 1).
- 2 Open the Diverter Assembly access door, and remove 1 screw (figure 6-10, callout 2).

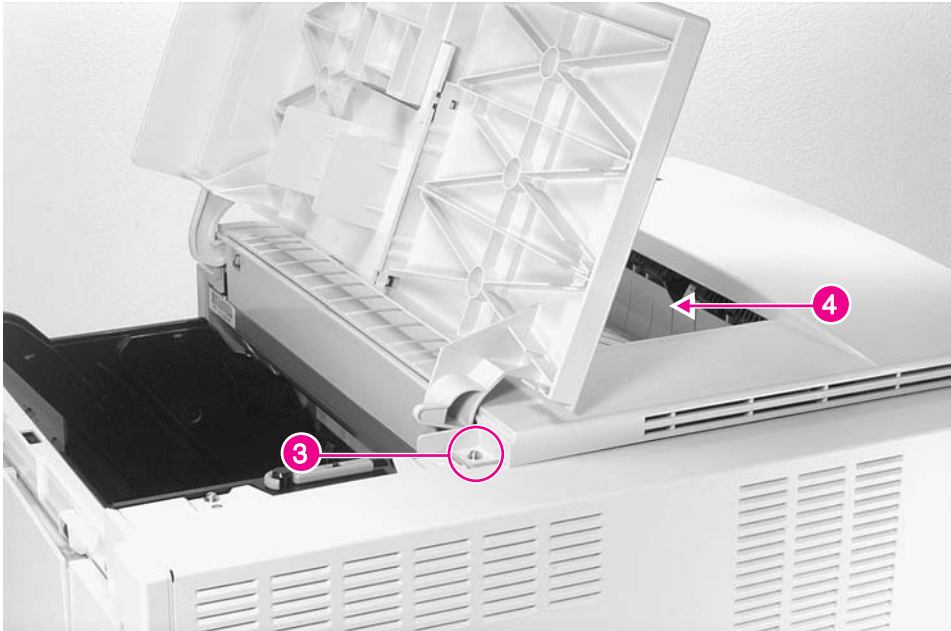

Figure 6-11 Top Cover (2 of 2)

- 3 Open the top cover door, and remove 1 screw (figure 6-11, callout 3).

CAUTION

Be careful not to damage the Face-down Bin Full sensor flag (figure 6-11, callout 4) when removing the top cover.

- 4 Lift (and hold) the top cover door up, and carefully pull out on the cover to release the retaining tab (figure 6-10, callout 5).
- 5 Hold the Face-down Bin (figure 6-10, callout 6) down while carefully and slowly lifting the top cover straight up until it clears the Face-down Bin Full sensor flag and the Delivery Unit.

To Reinstall:

CAUTION

Be careful not to damage the Face-down Bin Full sensor flag (figure 6-11, callout 4) when replacing the top cover.

- 1 Hold the top cover door up and the Face-down Bin (figure 6-10, callout 6) down while lowering the cover into position.
- 2 Slide the Face-down Bin under the Face-down Bin Full sensor flag, and make sure that the cam (figure 6-11, callout 4) at the rear of the top cover door is properly positioned while lowering the top cover into place.
- 3 Make sure that the top cover is seated properly and that the retaining tabs are in place before replacing the screws.

Delivery Unit (for Face-down Bin)

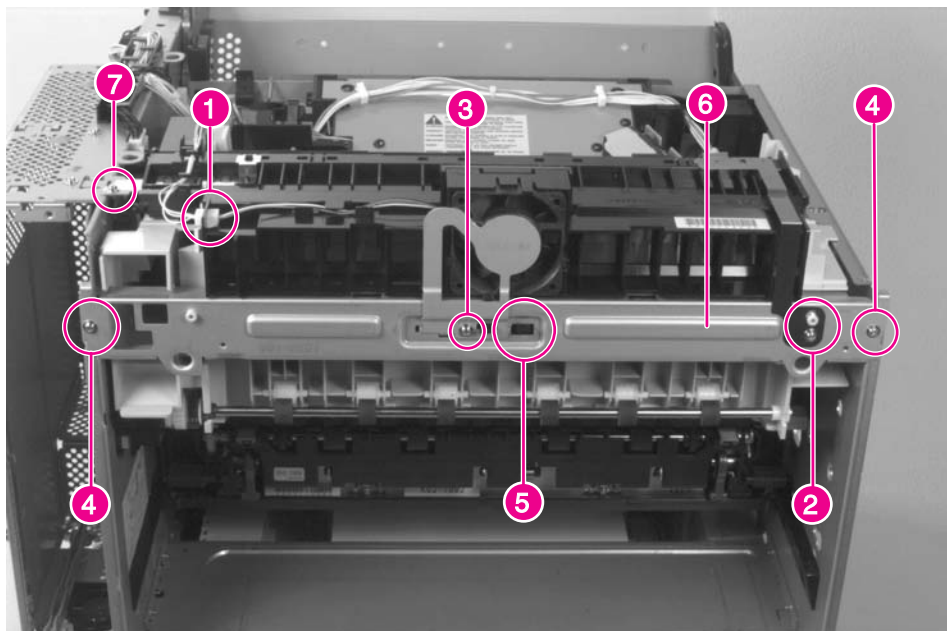

Figure 6-12 Delivery Unit (1 of 2)

- 1 Remove the following components:
 - Formatter Assembly (see figure 6-35 on page 251)
 - AC Access Cover (see figure 6-5 on page 218)
 - Top Cover (see figure 6-10 on page 223)
 - Front Cover (see figure 6-7 on page 220)
- 2 Unplug and re-route the fan cable out of the way (figure 6-12, callout 1).
- 3 Remove 1 screw (figure 6-12, callout 2) to loosen the grounding strip.
- 4 Remove 1 screw (figure 6-12, callout 3), and remove the metal fan shield.
- 5 Open the Diverter Assembly access door, remove 2 screws (figure 6-12, callout 4), release the plastic retaining tabs (figure 6-12, callout 5), and remove the metal mounting bracket (figure 6-12, callout 6).

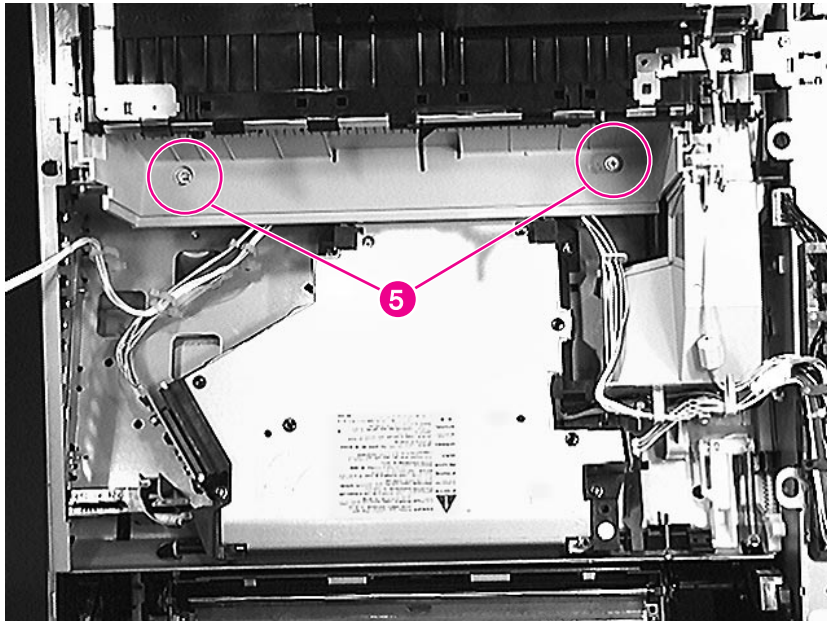

Figure 6-13 Delivery Unit (2 of 2)

- 6 Remove 2 screws (figure 6-12, callout 5) and 1 screw (figure 6-12, callout 7).

CAUTION

Be careful not to damage the plastic sensor flags and gears on the left end of the Delivery Unit.

- 7 Lift the left end of the Delivery Unit approximately 1/8 inch to clear the alignment pin, and carefully rock it forward and backward while sliding it out of the chassis.

To Reinstall:

CAUTION

Be careful not to damage the plastic sensor flags and gears on the left end of the Delivery Unit.

- 1 Place the plastic edge on the right end of the Delivery Unit into the chassis. Make sure that the plastic support tab on the right end of the Delivery Unit slides on top of the chassis.
- 2 Make sure that the plastic sensor flags and gears on the left end of the Delivery Unit can move freely.
- 3 Replace the metal mounting bracket (figure 6-12, callout 6) before replacing the Delivery Unit screws. Make sure that the plastic clips (figure 6-12, callout 5) are snapped into place before tightening the mounting screws (figure 6-12, callout 4).

Diverter Assembly

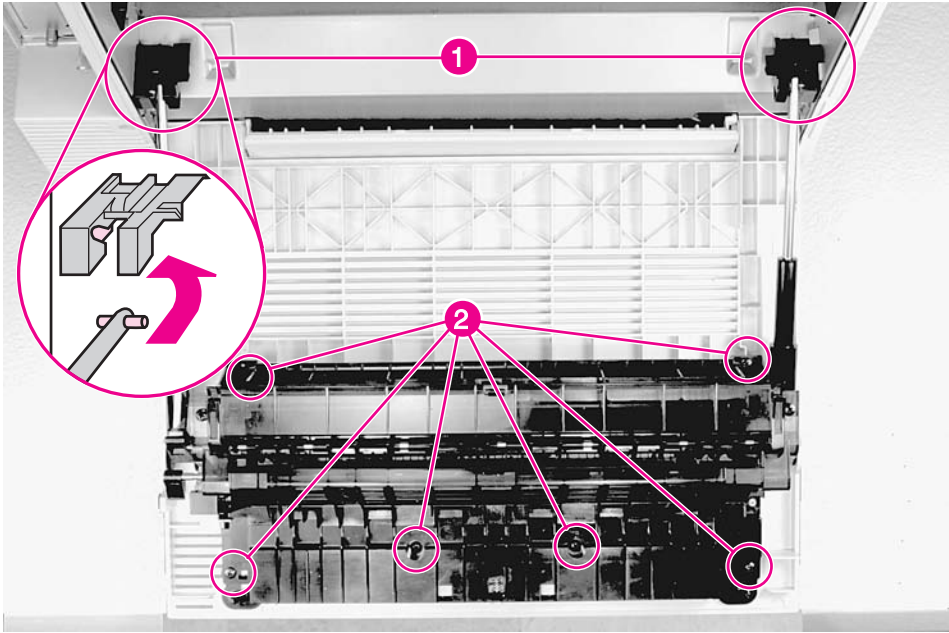

Figure 6-14 Diverter Assembly

CAUTION

Support the Diverter Assembly access door during this procedure to prevent damage to the plastic hinge pins.

- 1 Open the Diverter Assembly access door and release the support struts (figure 6-14, callout 1) by sliding the strut ends forward and downward.
- 2 Remove 6 self-tapping screws (figure 6-14, callout 2).

Note

The access door support struts will fall free when the Diverter Assembly is lifted away from the access door.

- 3 Lift the Diverter Assembly up and away from the access door.

Diverter Door Assembly

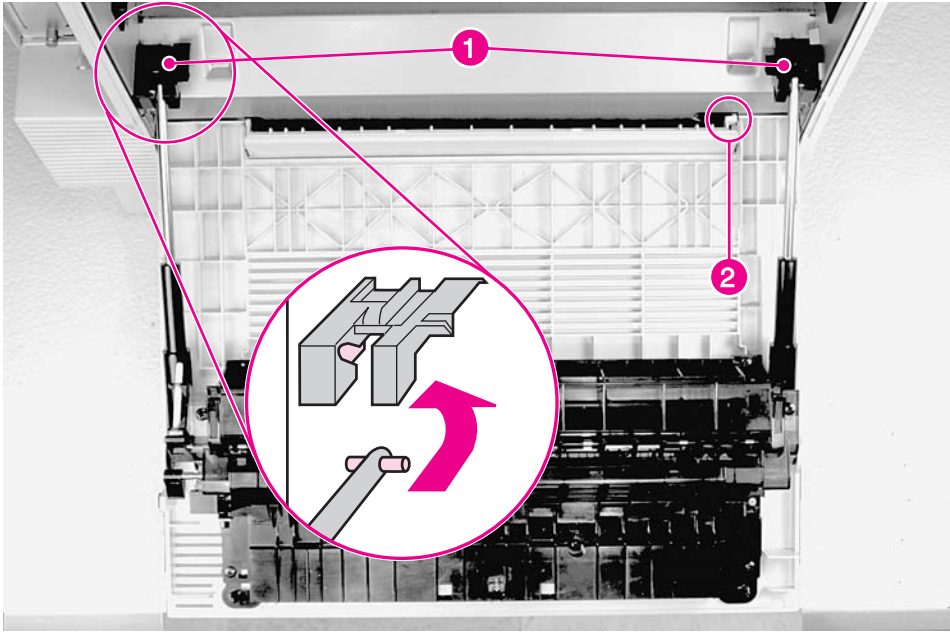

Figure 6-15 Diverter Door Assembly

- 1 Open the Diverter access door, and release the support struts (figure 6-15, callout 1) by sliding the strut ends forward and downward.
- 2 Rotate the door up to align the flat sides of the right hinge pin with the retaining slot (figure 6-15, callout 2), and lift upwards to release it from the retaining slot.
- 3 Continue lifting up on the right side of the door while pushing it to the left to rotate the left hinge pin out of its locating cavity.

To Reinstall:

- 1 Insert the left side of the door into position first, and then rotate the right side down to snap the hinge pins into position.
- 2 Reconnect the support struts to the chassis.

Lower Right Door Assembly

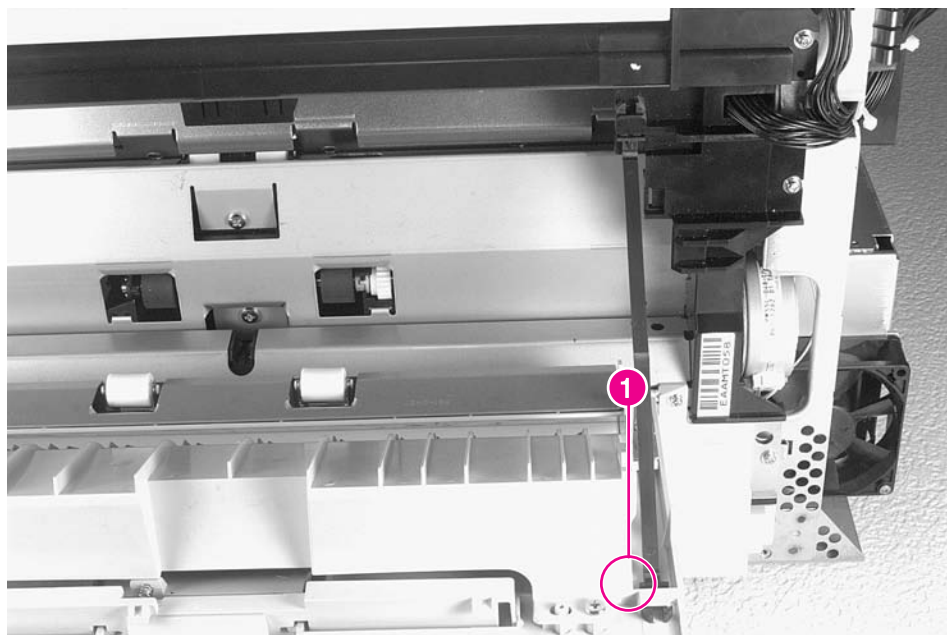

Figure 6-16 Lower Right Door Assembly (1 of 3)

- 1 Remove the back cover assembly (see figure 6-6).
- 2 Remove Tray 2 and Tray 3.
- 3 Open the Lower Right Door, and release the lower end of the support strap (figure 6-16, callout 1).

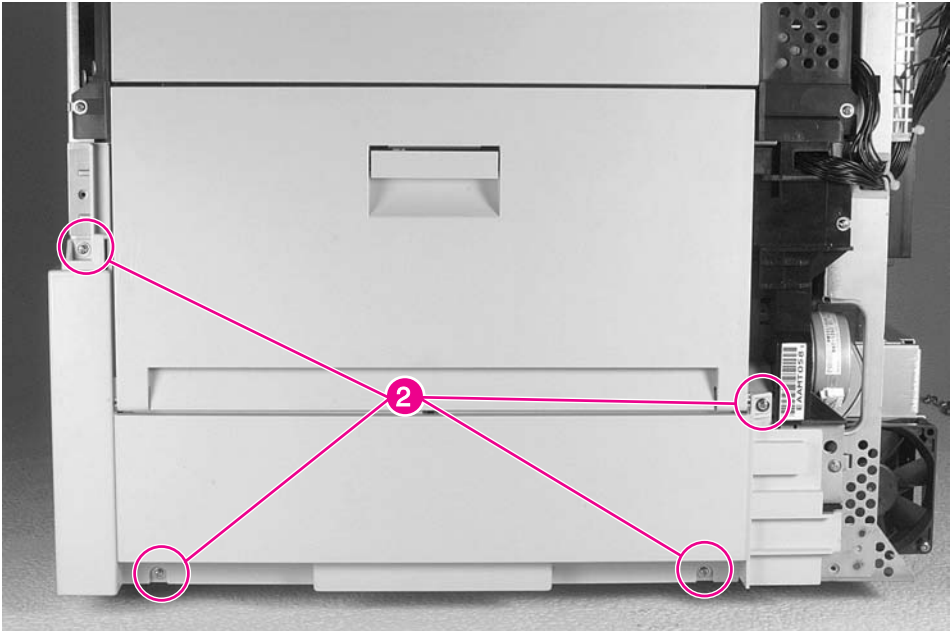

Figure 6-17 Right Lower Door Assembly (2 of 3)

- 4 Remove 4 screws (figure 6-17, callout 2).

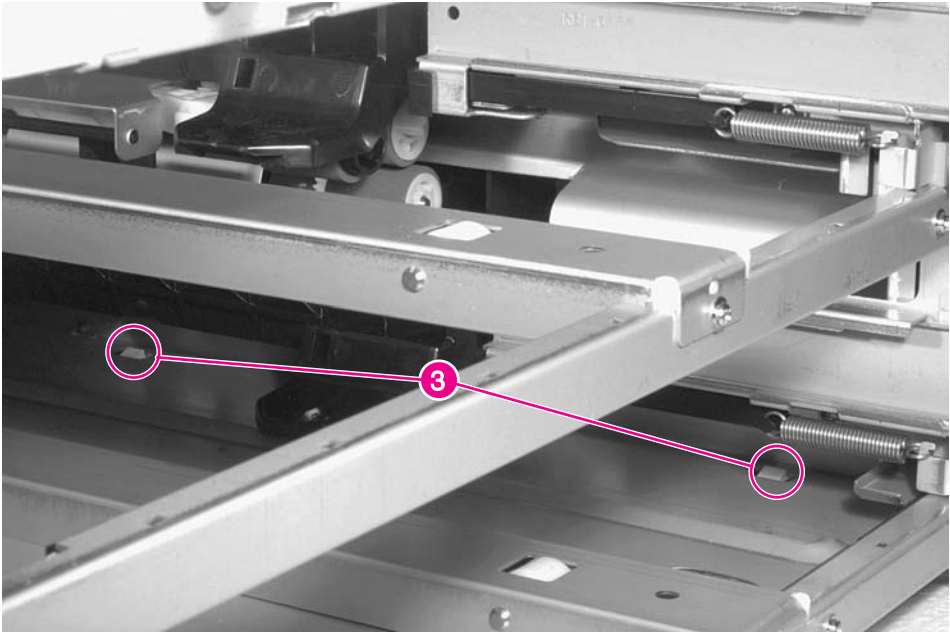

Figure 6-18 Right Lower Door Assembly (3 of 3)

- 5 Release two retainer tabs from the inside of the Tray 3 cavity (figure 6-18, callout 3).
- 6 Slide the door assembly away from the printer chassis.

Fan 1, Laser/Scanner and Housing (Exhaust)

Fan Housing

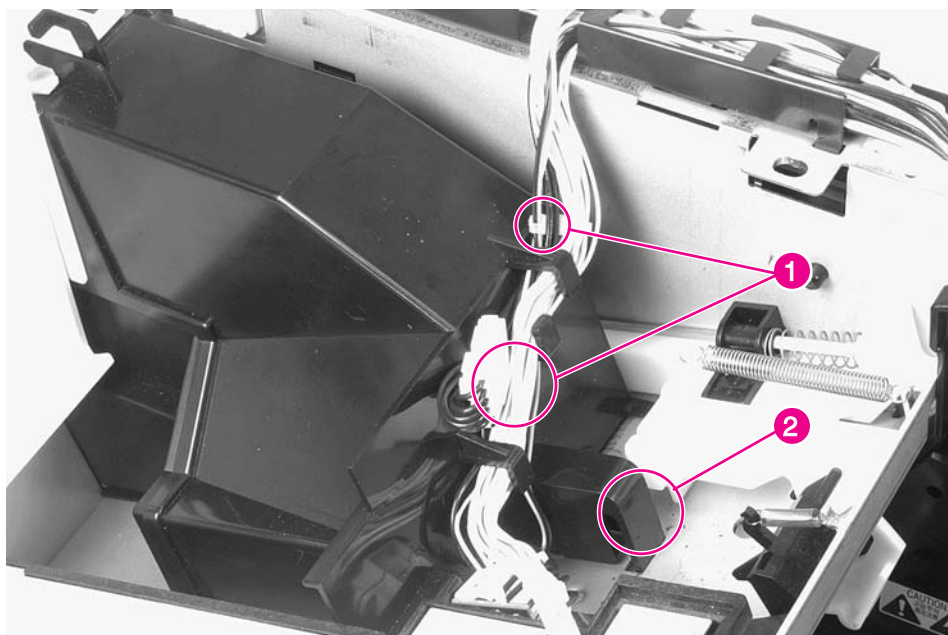

Figure 6-19 Fan 1, Laser/Scanner (1 of 2)

- 1 Remove the toner cartridge.
- 2 Remove the top cover (see figure 6-10 on page 223).
- 3 Remove and re-route the cables away from fan housing (figure 6-19, callout 1).
- 4 Release the housing retainer clip located inside the toner cartridge cavity (figure 6-19, callout 2), and lift the housing up and out of the chassis.

Fan 1 Motor

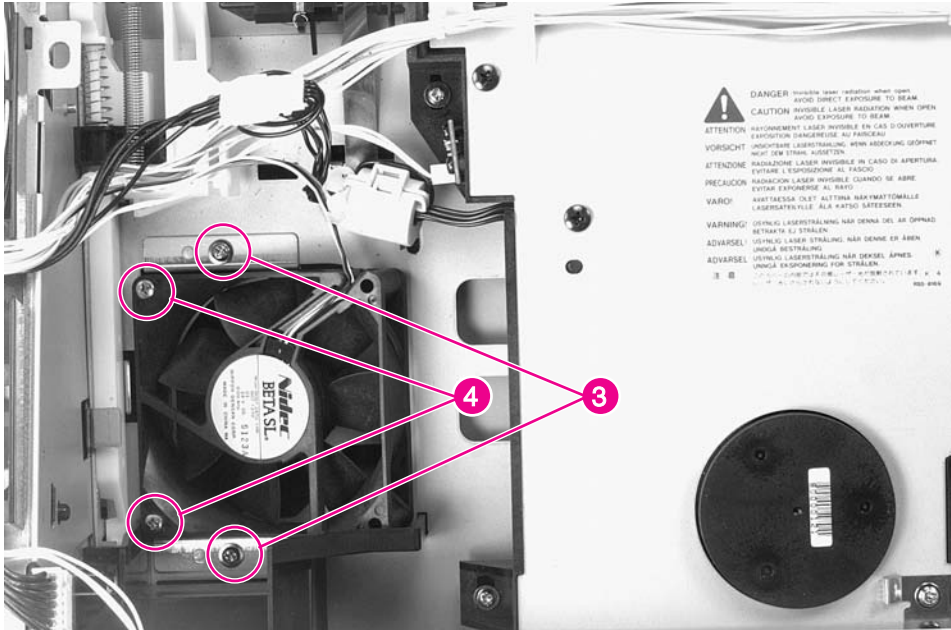

Figure 6-20 Fan 1, Laser/Scanner (2 of 2)

- 1 Unplug the fan cable from the DC Controller PCA.
- 2 Remove 2 screws (figure 6-20, callout 3), and lift the fan and bracket assembly out of the chassis.
- 3 Remove 2 screws (figure 6-20, callout 4) to separate the fan motor from the bracket.

Fan 2, Low Voltage Power Supply (Exhaust)

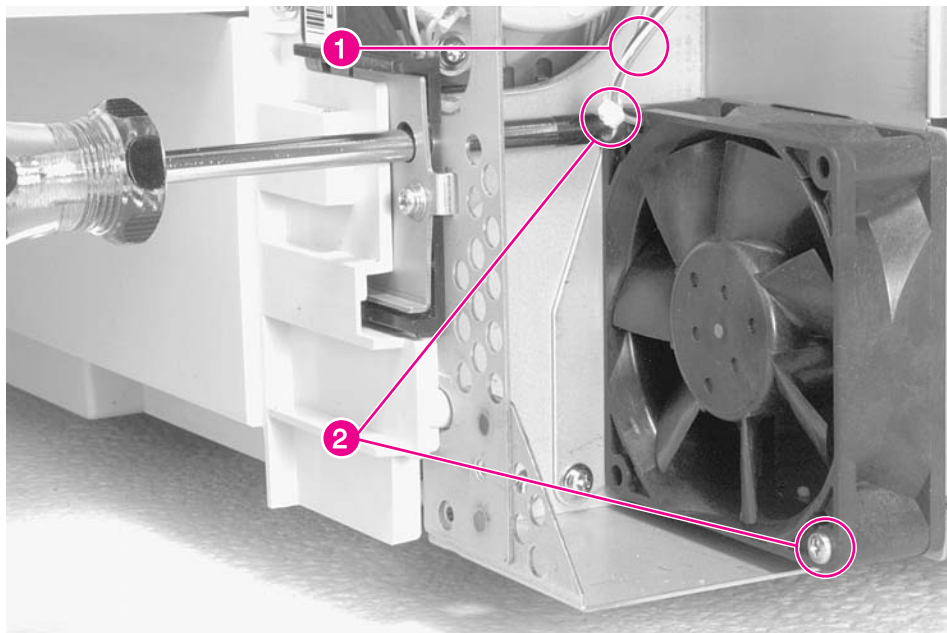

Figure 6-21 Fan 2, Low Voltage Power Supply

- 1 Remove the back cover (see figure 6-6 on page 219).
- 2 Remove the fan cable from the DC Controller PCA (figure 6-21, callout 1).
- 3 Remove 2 screws (figure 6-21, callout 2).

Fan 3, Formatter Fan and Housing (Intake)

Fan Motor

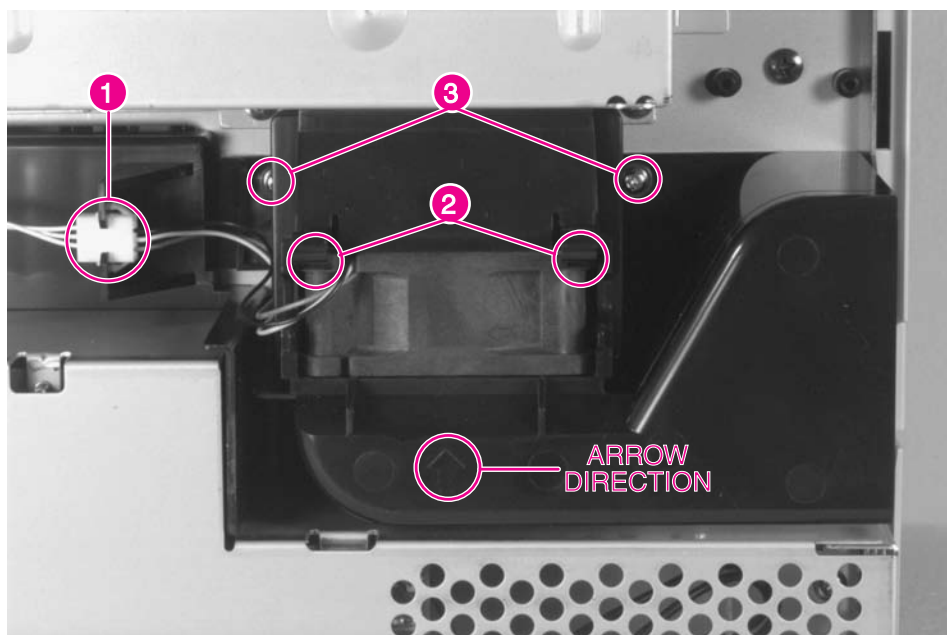

Figure 6-22 Fan 3, Formatter Fan

Note

The fan motor (FM3) can be removed without removing the housing assembly.

- 1 Remove the back cover (see figure 6-6 on page 219).
- 2 Unplug the fan connector (figure 6-22, callout 1).

CAUTION

Do not bend the fan retainer clips upward. Release them by pinching.

- 3 Release the 2 retainer clips (figure 6-22, callout 2), and slide the fan out of the housing assembly.

Fan Housing

- 4 Remove 2 screws and remove housing.

To Reinstall:

Make sure that the fan cable exits from the upper left corner.

Fan 4, Delivery Unit (Exhaust)

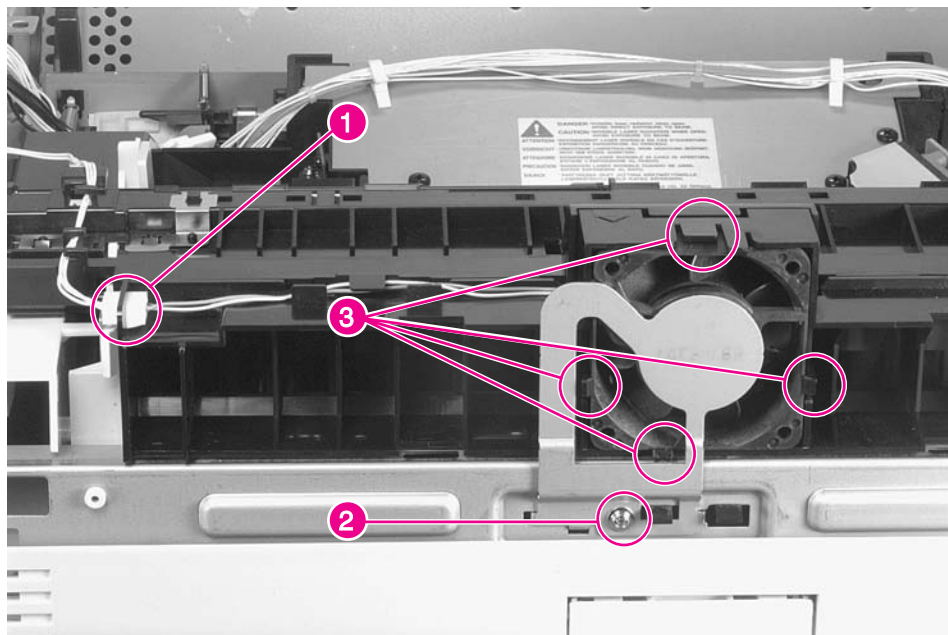

Figure 6-23 Fan 4, Delivery Unit

- 1 Remove the top cover (see figure 6-10).
- 2 Unplug the fan cable (figure 6-23, callout 1).
- 3 Remove 1 screw (figure 6-23, callout 2), and remove the metal fan shield.
- 4 Release 4 retainer clips (figure 6-23, callout 3), and slide the fan forward out of the Delivery Unit Assembly.

Fan 5, Tray 1 (Intake)

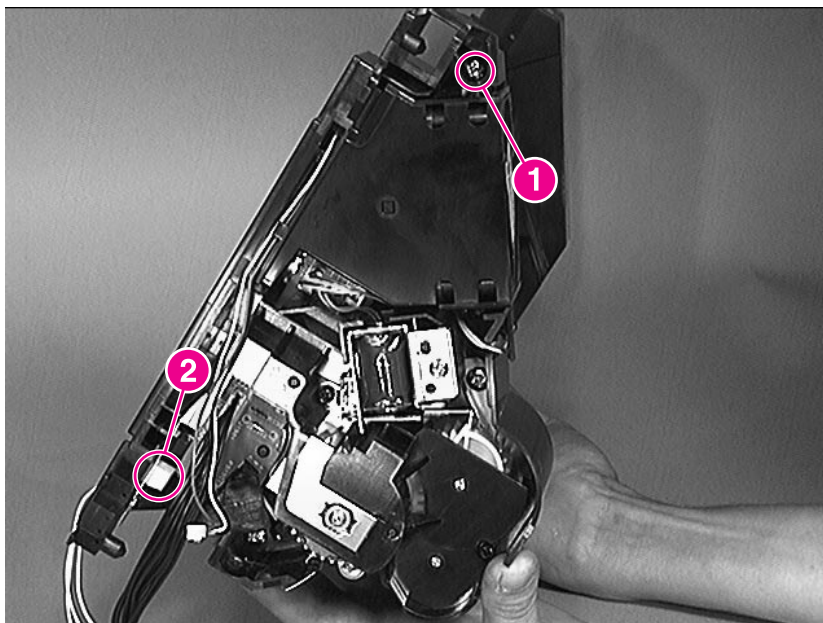

Figure 6-24 Fan 5 Removal (1 of 2)

- 1 Remove Tray 1.
- 2 Remove the Tray 1 Pickup Unit.
- 3 Remove 1 screw (callout 1).
- 4 Disconnect the cable (callout 2). Cable is shown disconnected.

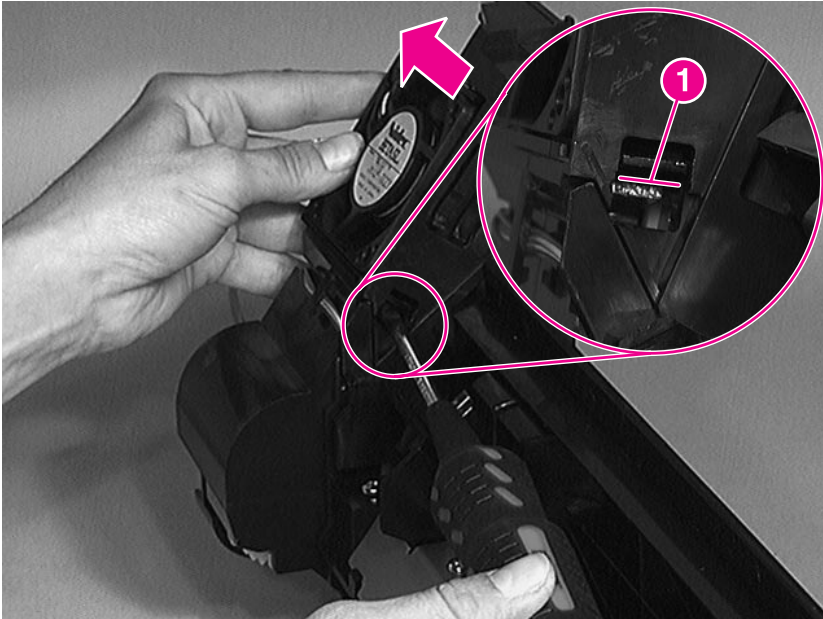

Figure 6-25 Fan 5 Removal (2 of 2)

- 5 Insert the flat blade of a screwdriver along the line indicated by callout 1.
- 6 Turn the screwdriver counter-clockwise slightly to free the fan housing from the fan duct. Then, slide the fan housing out of the duct.
- 7 Slide the fan out of the housing to replace it.

Tray 1

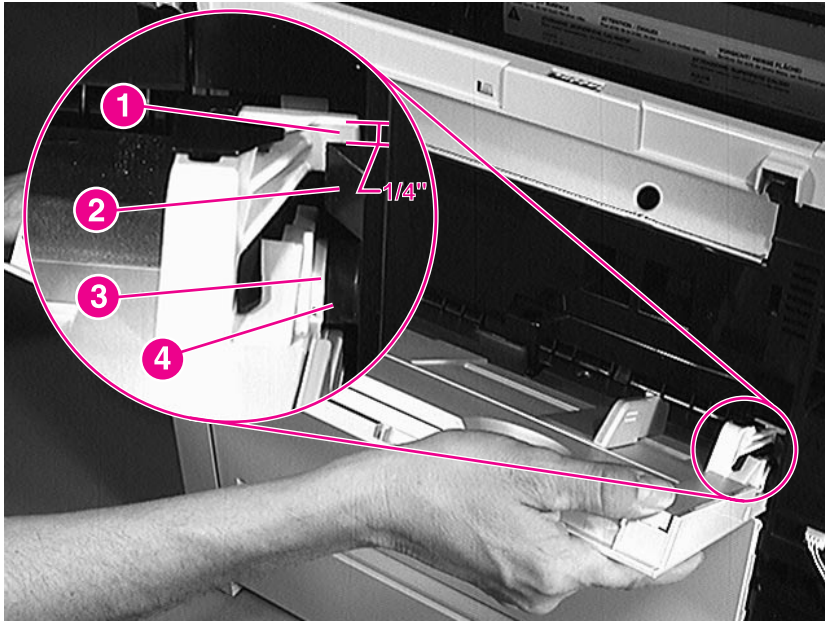

Figure 6-26 Tray 1 Removal (1 of 3)

- 1 To remove Tray 1, open the tray fully, then partially close it until the distance between the retaining tab (callout 1) and the stop on the chassis (callout 2) is 1/4".
- 2 Pull the right side of the tray outward to free the clip (callout 3) from the pin (callout 4).

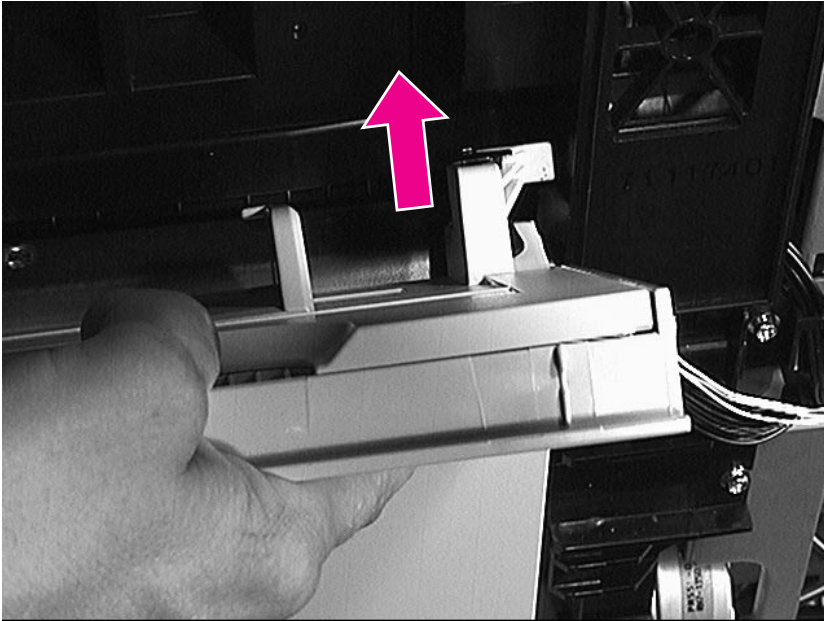

Figure 6-27 Tray 1 Removal (2 of 3)

- 3** Raise the right side of the tray and guide the white tab around the stop.

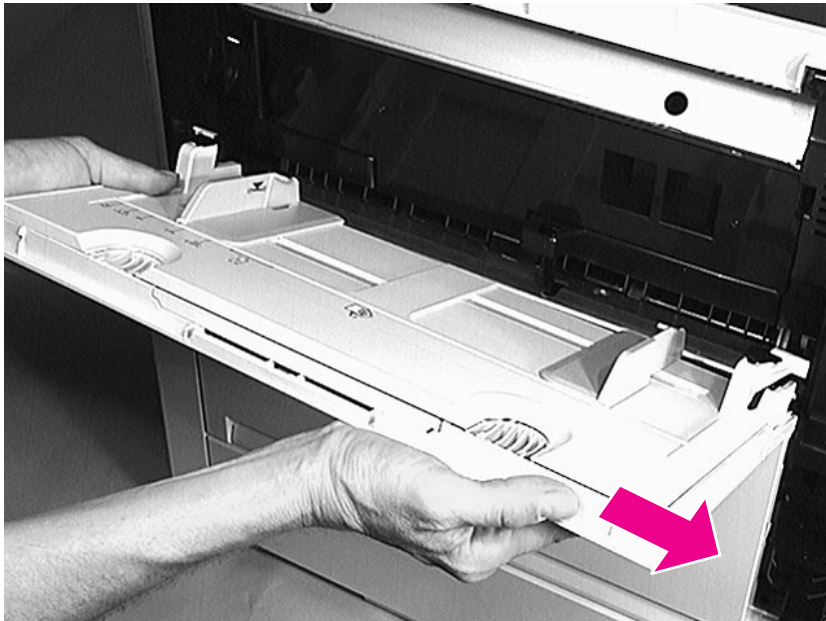

Figure 6-28 Tray 1 Removal (3 of 3)

- 4 Slide the tray to the right, to free the tray on the left side of the chassis.
- 5 Remove the tray.

Tray 1 Pickup Assembly

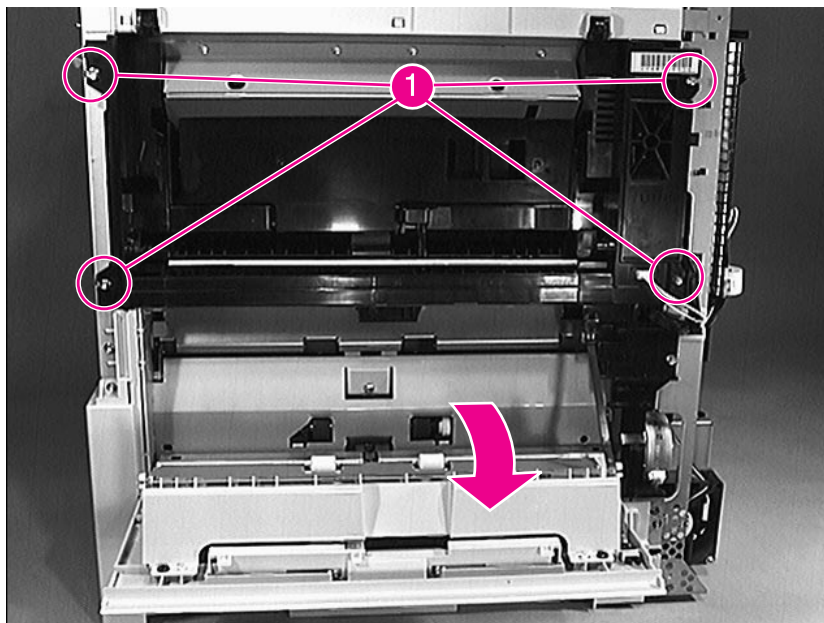

Figure 6-29 Tray 1 Pickup Unit Removal (1 of 4)

- 1 Remove the Front Cover.
- 2 Remove the Rear Cover.
- 3 Remove Tray 1(see page 241).
- 4 Open the Pickup Unit door.
- 5 Remove 4 screws (callout 1).

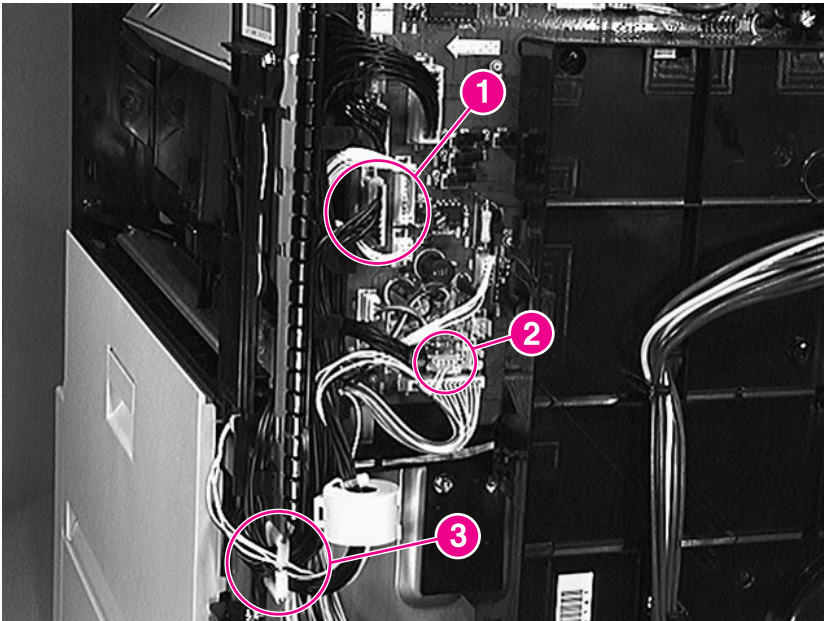

Figure 6-30 Tray 1 Pickup Unit Removal (2 of 4)

- 6 Disconnect the cables (callouts 1 and 2) on the right side of the printer.
- 7 Remove the cable from the cable guide (callout 3).

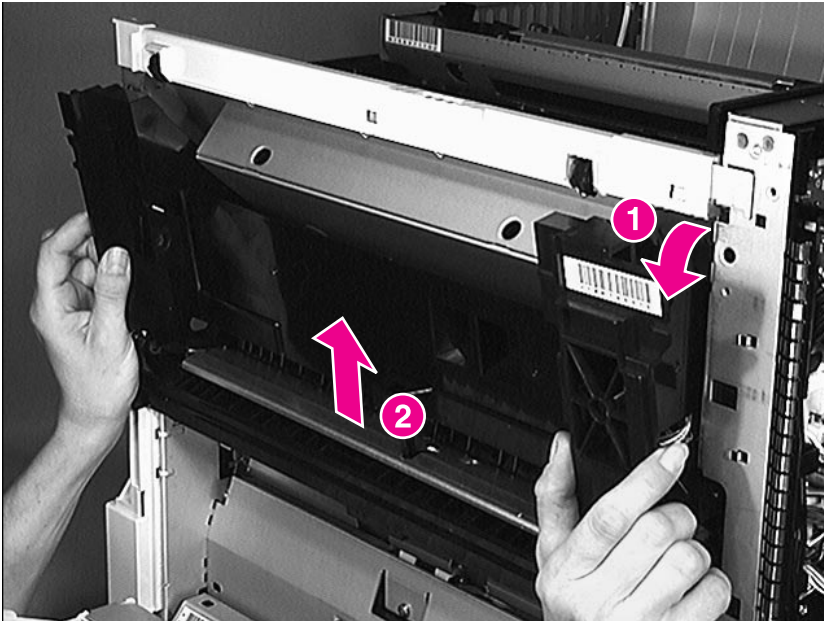

Figure 6-31 Tray 1 Pickup Unit Removal (3 of 4)

- 8 Tilt the Pickup Assembly out of the chassis from the top (callout 1), then lift up to free it from the chassis (callout 2).
- 9 Remove the Pickup Assembly from the chassis.

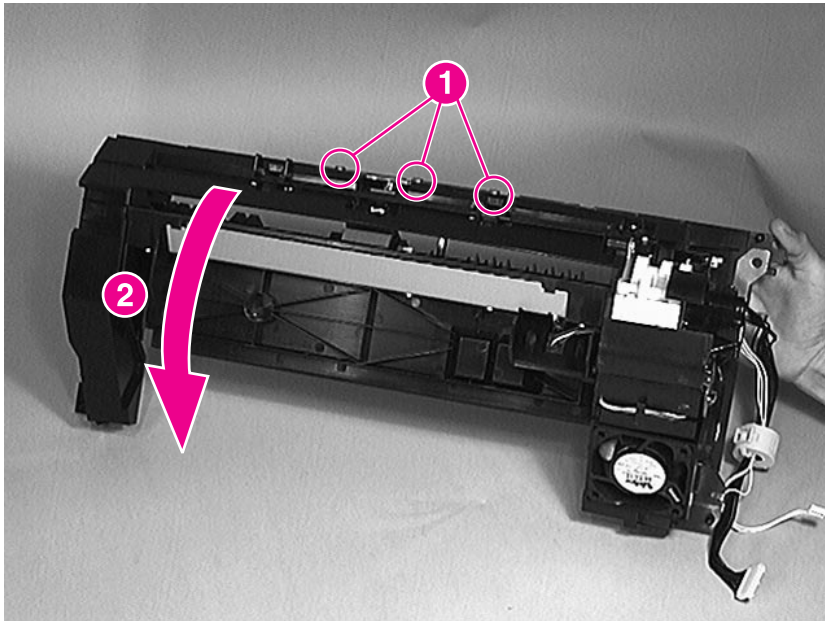

Figure 6-32 Tray 1 Pickup Unit Removal (4 of 4)

To Reinstall:

First, seat the 3 tabs (callout 1) behind the metal rail on the chassis. Then, pivot the Pickup Unit into place. The Pickup Unit has 4 locating pins that will engage guide holes in the chassis when the unit is properly aligned.

Feeder Assembly

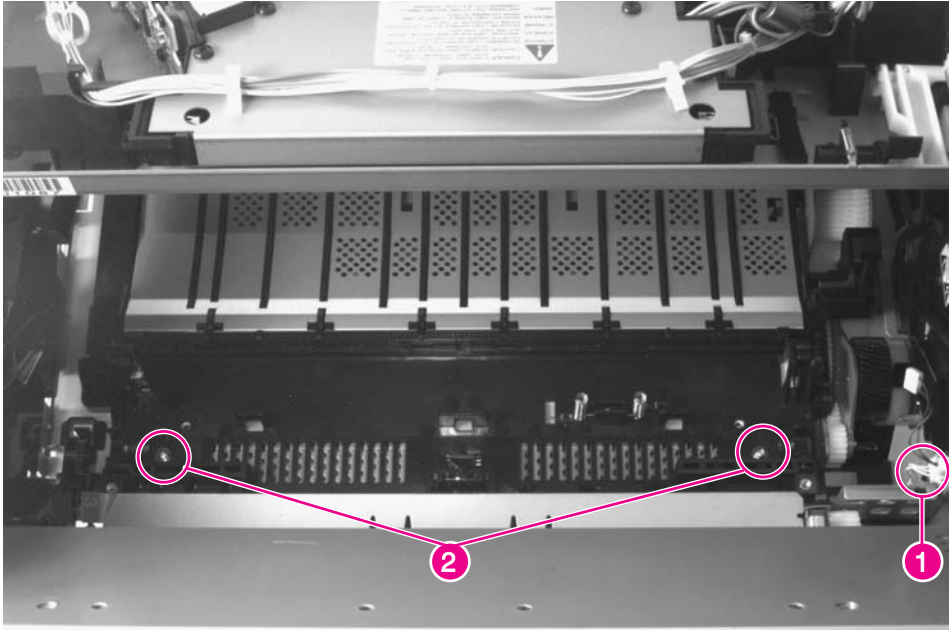

Figure 6-33 Feeder Assembly (1 of 2)

- 1 Open the left access door and remove the Duplexer (if installed).
- 2 Remove the Fusing Assembly (see figure 6-36 on page 252).
- 3 Open the Top Cover and remove the Toner Cartridge.
- 4 Remove the Transfer Roller Assembly (see figure 6-62 on page 282).
- 5 Remove the Registration Assembly (see figure 6-53 on page 271).
- 6 Unplug the sensor cable at the right side of the Feeder Assembly (figure 6-33, callout 1).
- 7 Remove 2 screws at the front of the Feeder Assembly (figure 6-33, callout 2).



Figure 6-34 Feeder Assembly (2 of 2)

- 8 Remove 1 screw at the back of the Feeder Assembly (figure 6-34).

Note

Removing the High Voltage Power Supply is recommended to ease the removal of the Feeder Assembly, primarily because of the contact points.

- 9 Release 4 plastic retaining tabs by moving them in the directions indicated in figure 6-34 while carefully lifting upwards on the Feeder Assembly.
- 10 Remove the Feeder Assembly by lifting it upwards out of the Toner Cartridge cavity.

To Reinstall:

Make sure that the plastic retaining tabs are all properly seated before replacing the screws.

Formatter Assembly

Setting Page Count, Maintenance Count, and Serial Number

The page count, maintenance count, and printer serial number are stored in Non-Volatile Memory. `PAGECOUNT` is the total number of images printed by the printer, `MAINTCOUNT` is the page count when the next preventive maintenance should be performed (every 350,000 images), and `S.N.` is the printer serial number (also located on the printer back cover).

CAUTION

DIMMs and the Formatter PCA can be damaged by small amounts of electrostatic discharge (ESD). Wear an anti-static wrist wrap.

If necessary to replace the Formatter PCA, these numbers should be set to the current values to accurately reflect the usage of the print engine. The procedures for setting these values are listed in table 3-14 on page 85.

Before removing the old Formatter PCA, print a Configuration Page to verify the current values.

Note

If it is not possible to print a Configuration Page, try to verify the values before replacing the Formatter PCA by following steps 1 through 3, below.

After verifying the page count, maintenance count, and printer serial number from the old Formatter PCA, replace it with the new PCA.

- 1 Enter Service Mode as described in “Mopier Service Mode” on page 85.
- 2 When `SERVICE MODE` is displayed, press **MENU** to access the Service Menu.
- 3 Press **ITEMS** to display `PAGECOUNT=`, `MAINTCOUNT=`, and `S.N.=`.
- 4 Enter the appropriate values for each item.
- 5 Press **GO** to exit Service Mode.

Note

The page count interval can be changed to a value less than 350, 000 for special media situations.

Removing and Replacing the Formatter Assembly

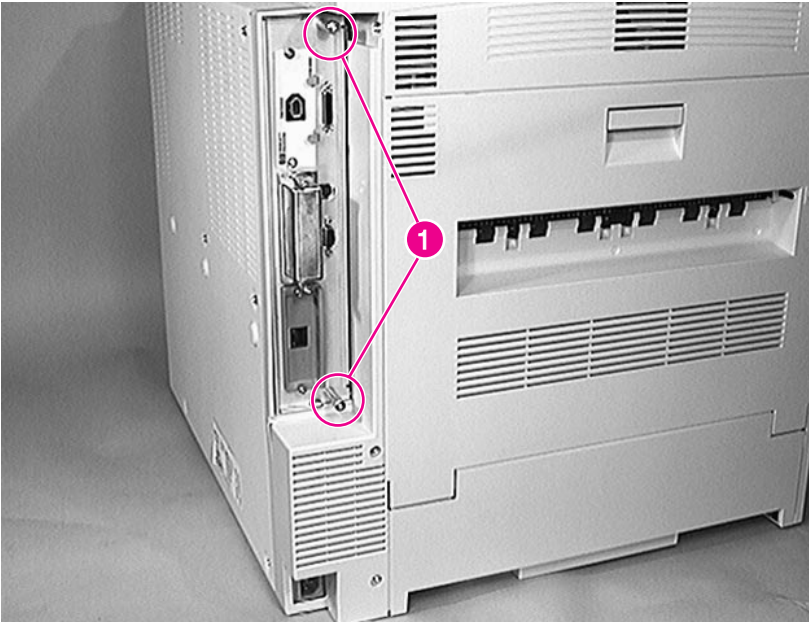

Figure 6-35 Formatter Assembly

- 1 If the Formatter is to be replaced, make sure to note the page count.
- 2 Loosen the two captive screws (figure 6-35, callout 1), and slide the Formatter PCA out of the chassis.
- 3 After installation of a replacement Formatter, be sure to re-enter the serial number, page count, and maintenance count. (See table 3-14 on page 85 for more information.)

Fusing Assembly

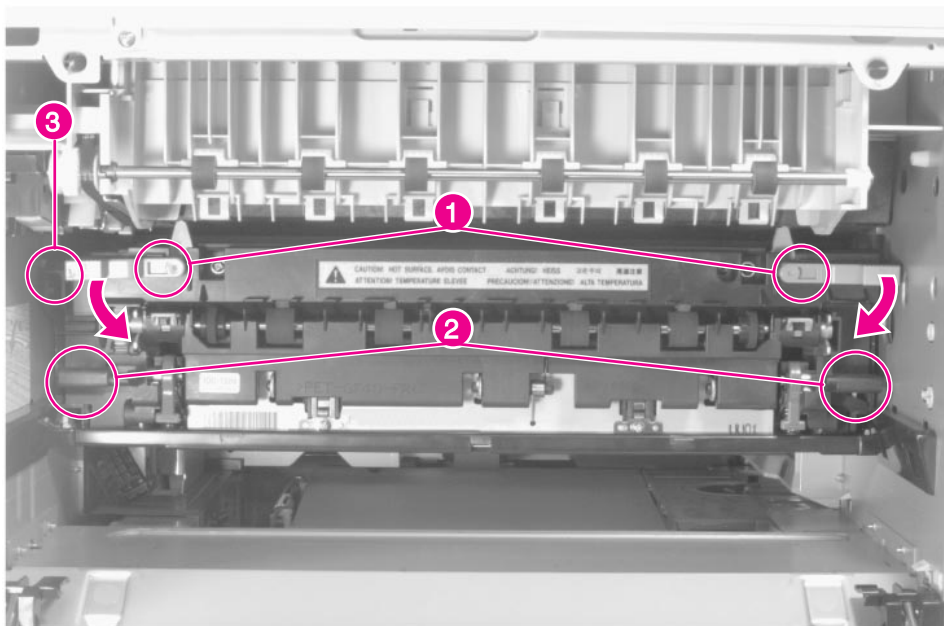

Figure 6-36 Fusing Assembly

- 1 Open the Diverter Assembly access door, and remove the Duplexer if installed.

CAUTION

Use the upper levers to release the Fusing Assembly, NOT the lower levers. The lower levers set the pressure rollers inside the Fusing Assembly for envelope printing (down for single sheets, up for envelopes).

- 2 To release the Fusing Assembly rotate the upper levers down (figure 6-36, callout 1).
- 3 To remove the Fusing Assembly lift up on the finger handles (figure 6-36, callout 2) while pulling outward.

To Reinstall:

- 1** Make sure that the Fuser Output sensor flag (figure 6-36, callout 3) on the upper left corner of the Fusing Assembly rotates freely.
- 2** Make sure that the lower levers are set down for single sheets. If having trouble printing envelopes, move the levers up. Move the levers back down when done.

Laser/Scanner Assembly

CAUTION



The Laser/Scanner diode is extremely sensitive to ESD.

- 1 Remove the toner cartridge.
- 2 Remove the top cover (see figure 6-10).

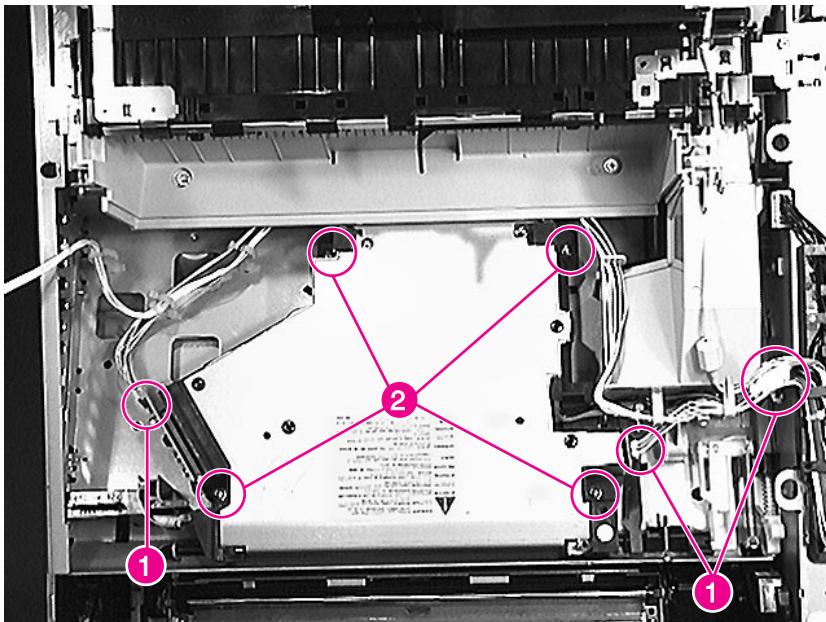

Figure 6-37 Laser/Scanner Assembly

- 3 Unplug three cable connectors (figure 6-37, callout 1).

- 4 Re-route the cable running across the top of the assembly so that it is out of the way.

CAUTION

Do not touch the laser/scanner mirror located under the forward edge of the assembly. Use approved ESD handling procedures when touching the Beam Detect PCA.

- 5 Remove 4 screws (figure 6-37, callout 2).

To Reinstall:

Make sure that the locator pins are properly seated.

Main Gear Assembly

- 1 Remove the following components in the order listed:
 - Toner Cartridge
 - Tray 1
 - Tray 2
 - Transfer Roller Assembly (see figure 6-62 on page 282)
 - Back Cover Assembly (see figure 6-6 on page 219)
 - Tray 1 Pickup Assembly (see figure 6-26 on page 241)
 - Right Lower Door Assembly (see figure 6-16 on page 231)
 - Paper Input Unit (PIU) (see figure 6-42 on page 260)
 - High Voltage Power Supply (HVPS) (see figure 6-51 on page 269)
 - Main Motor (see figure 6-41 on page 259)

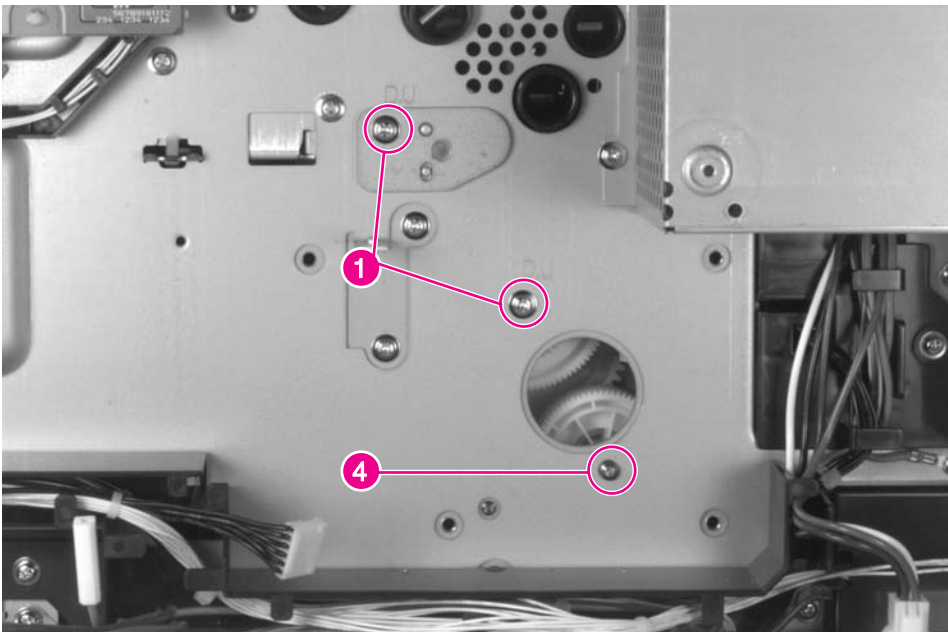

Figure 6-38 Main Gear Assembly (1 of 3)

- 2 Remove 2 screws (figure 6-38 on page 256, callout 1).

CAUTION

Be careful not to damage the plastic gears when removing the Main Gear Assembly.

Note

A slight gentle rocking motion will help free the Main Gear Assembly from the printer.

- 3 From inside of the PIU cavity, carefully tilt the bottom of the Main Gear Assembly away from the chassis and down to free the gear mechanisms.

To Reinstall:

Figure 6-39 Main Gear Assembly (2 of 3)

Note

A slight gentle rocking motion will help install the Main Gear Assembly as it is rotated into place.

- 1 Observe the gear assembly position from inside the toner cartridge cavity (figure 6-39, callout 2).

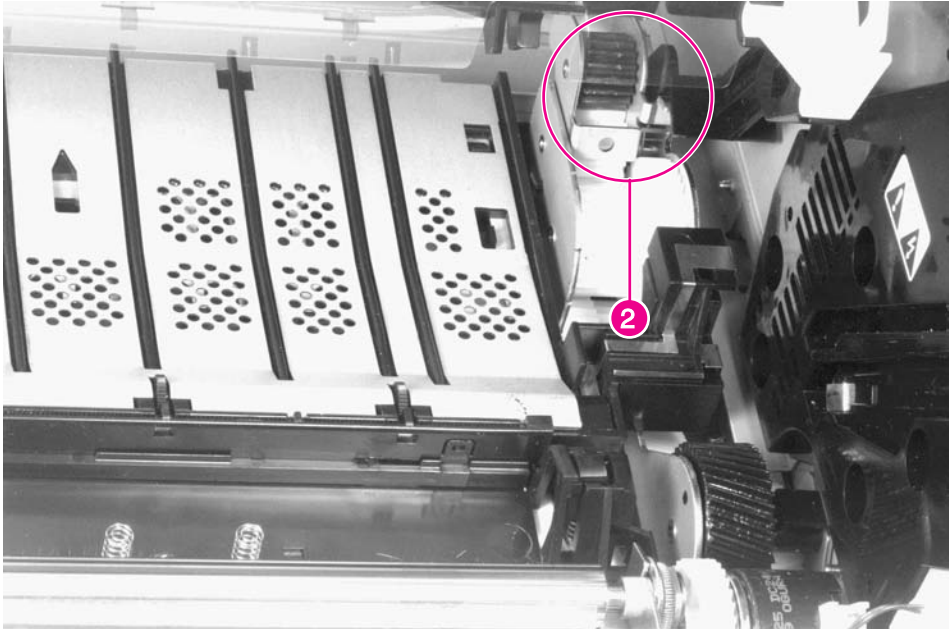
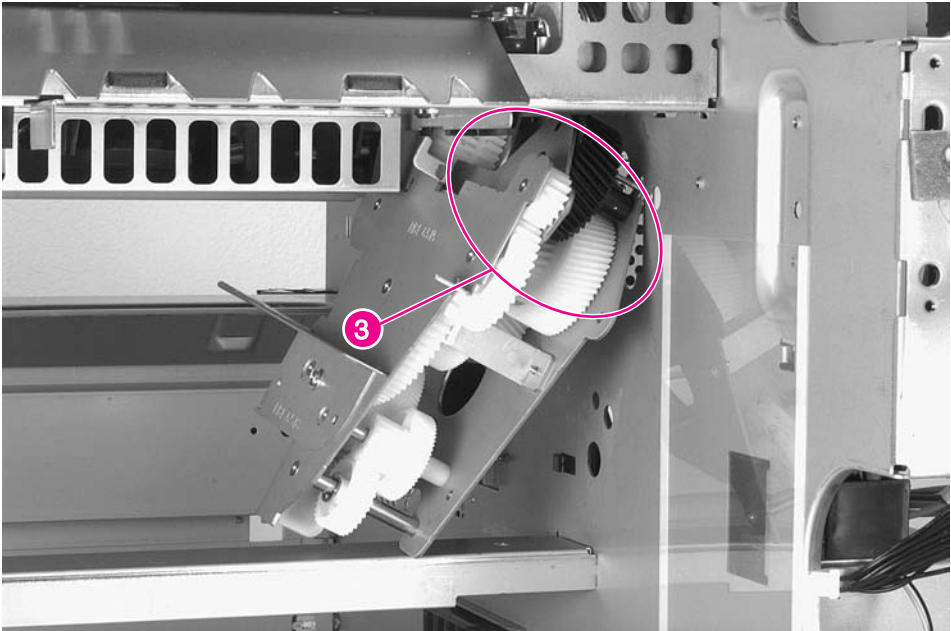

Figure 6-40 Main Gear Assembly (3 of 3)

- 2 Tilt the top of the assembly inward and insert the upper back part of the assembly in place (figure 6-40, callout 3).
- 3 Continue rotating the assembly upwards into place.
- 4 Make sure that the locating pins are properly aligned and that the gear assembly fits tightly against the chassis before replacing the screws (figure 6-38, callout 4).

Main Motor Assembly

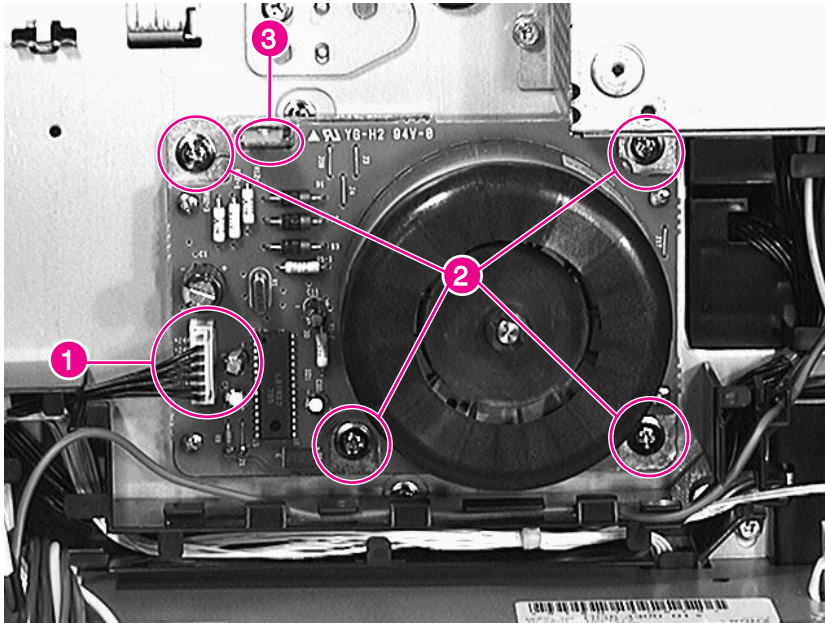

Figure 6-41 Main Motor

- 1 Remove the back cover (see figure 6-6 on page 219).
- 2 Remove the HVPS (see figure 6-51 on page 269).
- 3 Unplug the connector (figure 6-41, callout 1).

CAUTION

Be careful when removing the Main Motor. The steel drive shaft can damage the plastic gears.

- 4 Remove 4 screws (figure 6-41, callout 2).

To Reinstall:

Align the Main Motor to the chassis with the locator tab (figure 6-41, callout 3) and the machined ring around the output shaft.

Paper Input Unit (PIU)

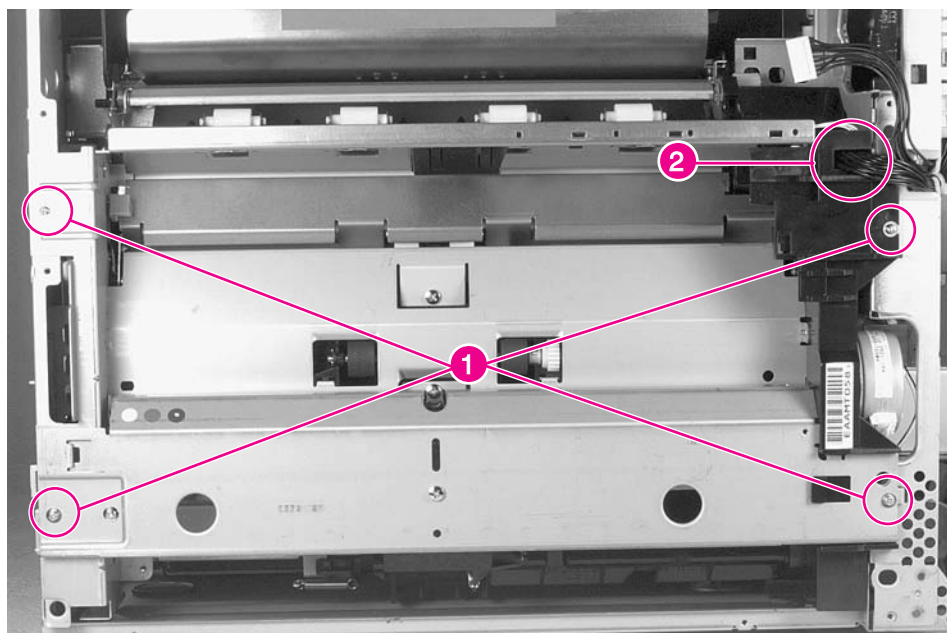

Figure 6-42 Paper Input Unit

- 1 Remove Tray 2 and Tray 3. Remove both trays to prevent damage to the PIU plastic sensor flags.
- 2 Remove the back cover (see figure 6-6 on page 219).
- 3 Remove the Tray 1 Pickup Assembly (see figure 6-29 on page 244).
- 4 Remove the Right Lower Door Assembly (see figure 6-16 on page 231).
- 5 Remove 4 screws (figure 6-42, callout 1).
- 6 Slide the assembly out from the chassis approximately 3 inches, and unplug the connector inside the right end (figure 6-42, callout 2).
- 7 Continue sliding the assembly out of the chassis.

To Reinstall:

Make sure that Trays 2 and 3 are removed when reinstalling the Paper Input Unit.

PCA, DC Controller

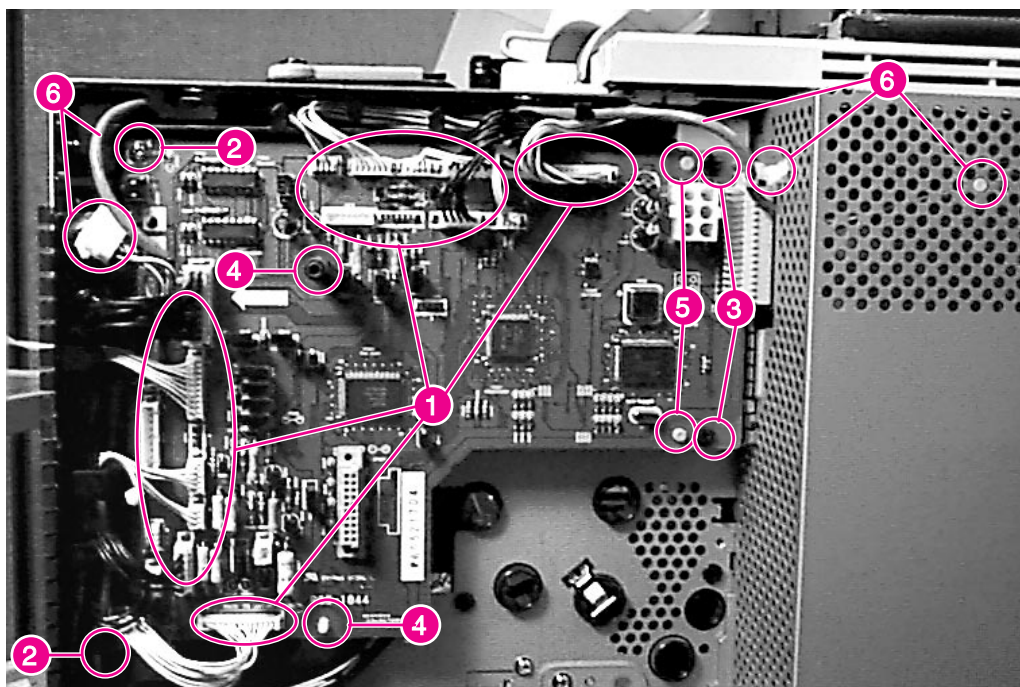

Figure 6-43 DC Controller PCA

- 1 Remove the Formatter Assembly (see figure 6-35 on page 251).
- 2 Remove the back cover (see figure 6-6 on page 219).
- 3 Remove the High Voltage Power Supply (see figure 6-51 on page 269).
- 4 Unplug 19 connectors from the PCA (figure 6-43, callout 1).
- 5 Remove 2 screws (figure 6-43, callout 2) from the left side of the PCA and 2 self-tapping screws (figure 6-43, callout 3) from the right side of the PCA.
- 6 Release two retaining clips (figure 6-43, callout 4) and carefully tip the left side of the PCA outward to clear the Formatter PCA connector from the card cage.

To Reinstall:

Make sure the retaining clip posts (figure 6-43, callout 4) and the two locator pins (figure 6-43, callout 5) are properly aligned.

Output Paper Sensor PCA

- 1 Remove the following components in the order listed:
 - Toner Cartridge
 - Formatter Assembly (see figure 6-35 on page 251)
 - AC Access Cover (see figure 6-5 on page 218)
 - Top Cover (see figure 6-10 on page 223)
 - Back Cover (see figure 6-6 on page 219)
 - Fan 3 and Housing Assembly (see figure 6-22 on page 237)
 - High Voltage Power Supply (HVPS) (see figure 6-51 on page 269)
 - DC Controller PCA (see figure 6-43)

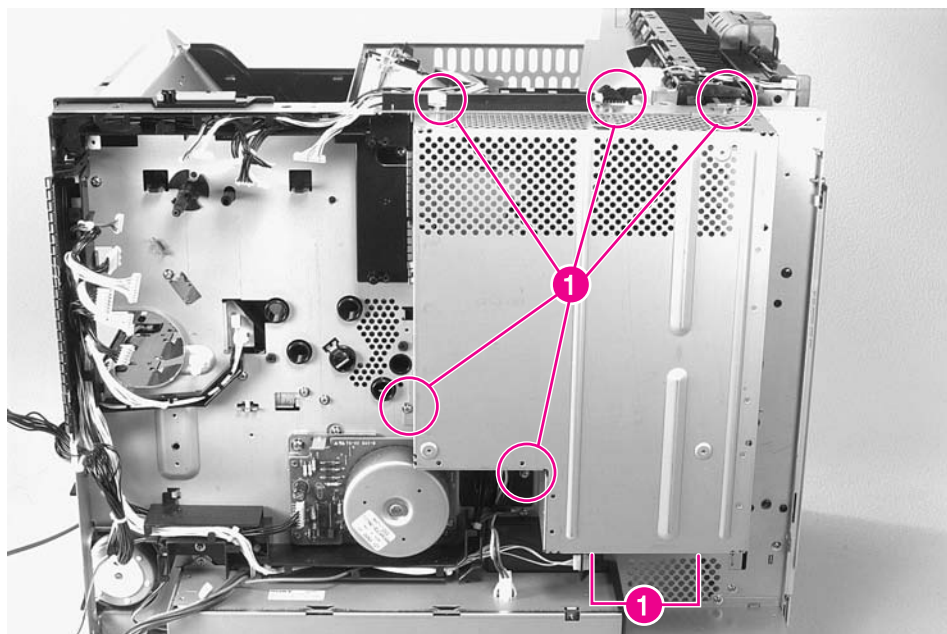

Figure 6-44 Output Paper Sensor PCA (1 of 4)

- 2 Remove 7 screws (figure 6-44, callout 1), and remove the Formatter PCA cage.

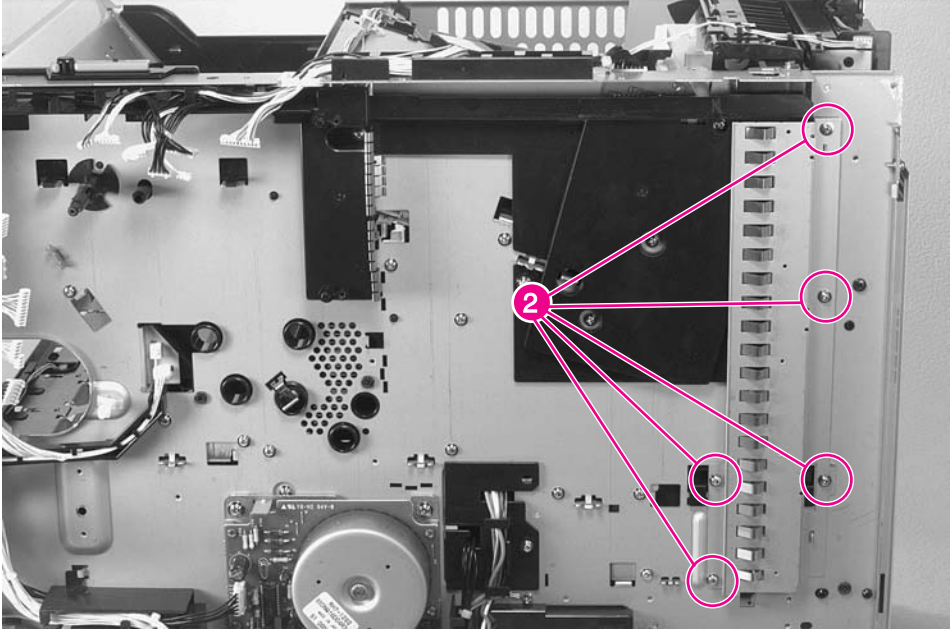

Figure 6-45 Output Paper Sensor PCA (2 of 4)

- 3** Remove 5 screws (figure 6-45, callout 2), and remove the Formatter PCA grounding strip.

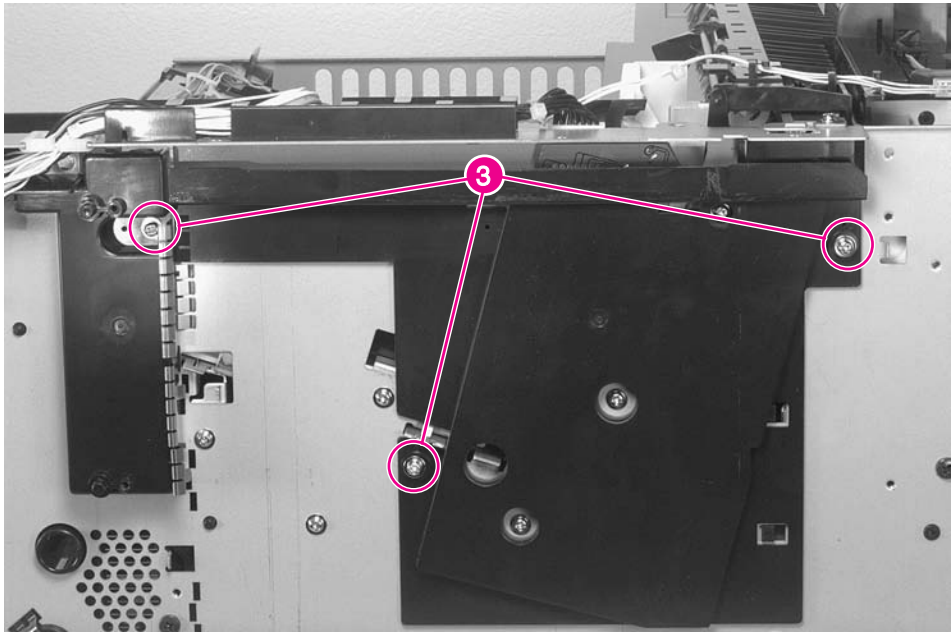

Figure 6-46 Output Paper Sensor PCA (3 of 4)

- 4 Remove 3 screws (figure 6-46, callout 3), and remove the plastic PCA shield. (Note the positioning of the metal grounding fingers at the left of the shield.)

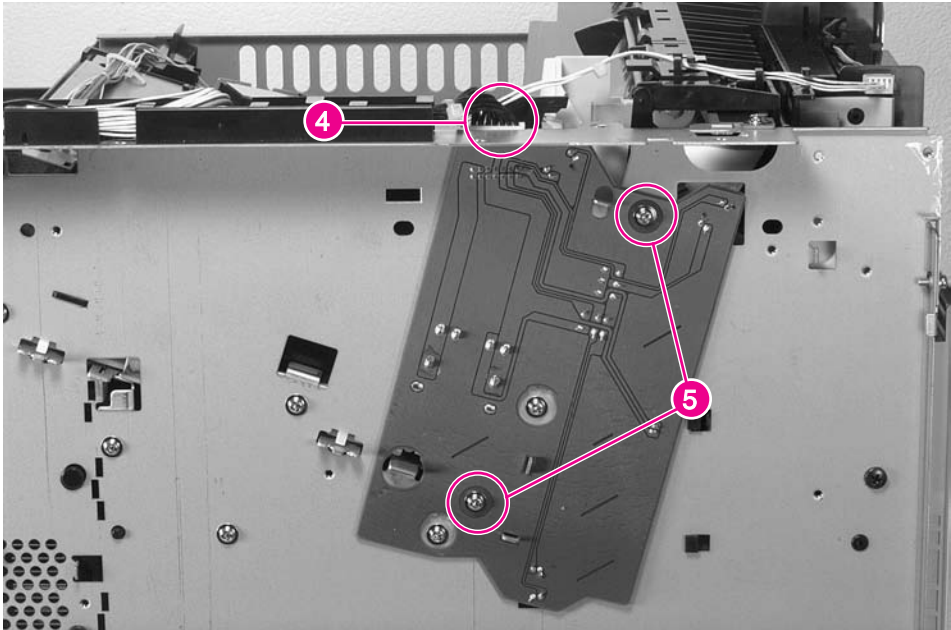

Figure 6-47

Output Paper Sensor PCA (4 of 4)

- 5 Unplug the connector (figure 6-47, callout 4).
- 6 Remove 2 screws (figure 6-47, callout 5), and unplug the connector on the back side of the PCA.

To Reinstall:

Make sure that the sensor flags rotate freely and that the top cover and Diverter doors operate the microswitch (SW1401).

Paper Size PCA

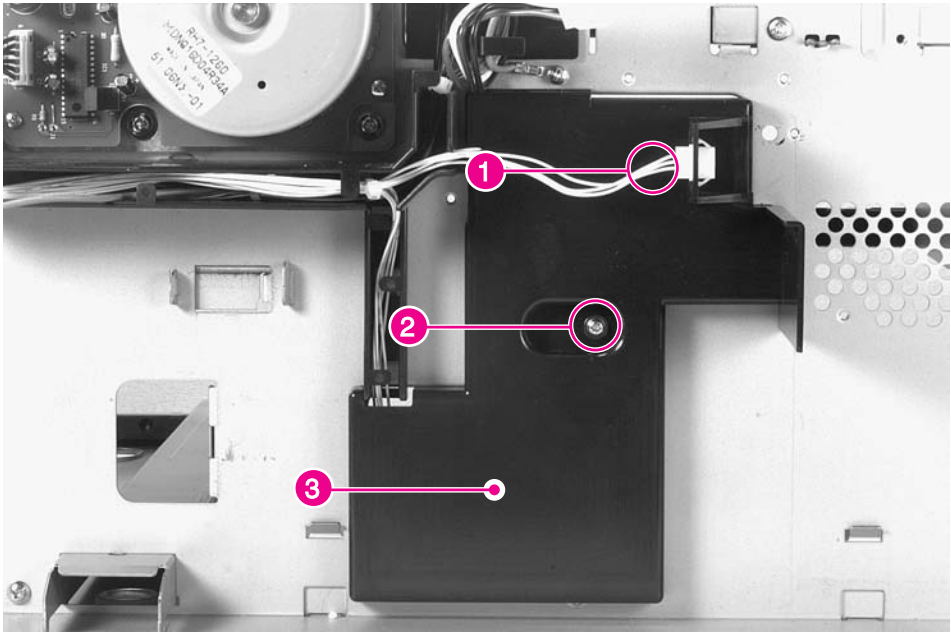

Figure 6-48 Paper Size PCA (1 of 3)

- 1 Remove the following components in the order listed:
 - Toner Cartridge
 - Trays 2 and 3
 - Back Cover (see figure 6-6)
 - Low Voltage Power Supply (LVPS) (see figure 6-52)
- 2 Unplug the fan cable from the left side of the connector (figure 6-48, callout 1), remove 1 screw (figure 6-48, callout 2), and remove the plastic shield (figure 6-48, callout 3).

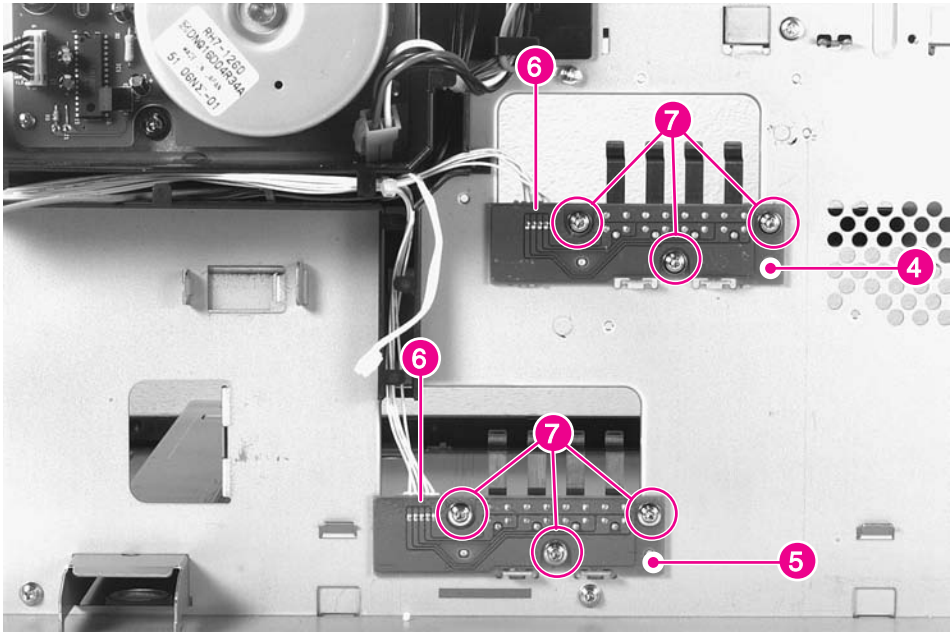

Figure 6-49 Paper Size PCA (2 of 3)

Note

The Paper Size PCA for Tray 2 (figure 6-49, callout 4) is identical to the PCA for Tray 3 (figure 6-49, callout 5). The removal procedure for both PCAs is the same.

- 3 Unplug the connector (figure 6-49, callout 6), remove 3 screws (figure 6-49, callout 7), and remove the PCA and actuating fingers.

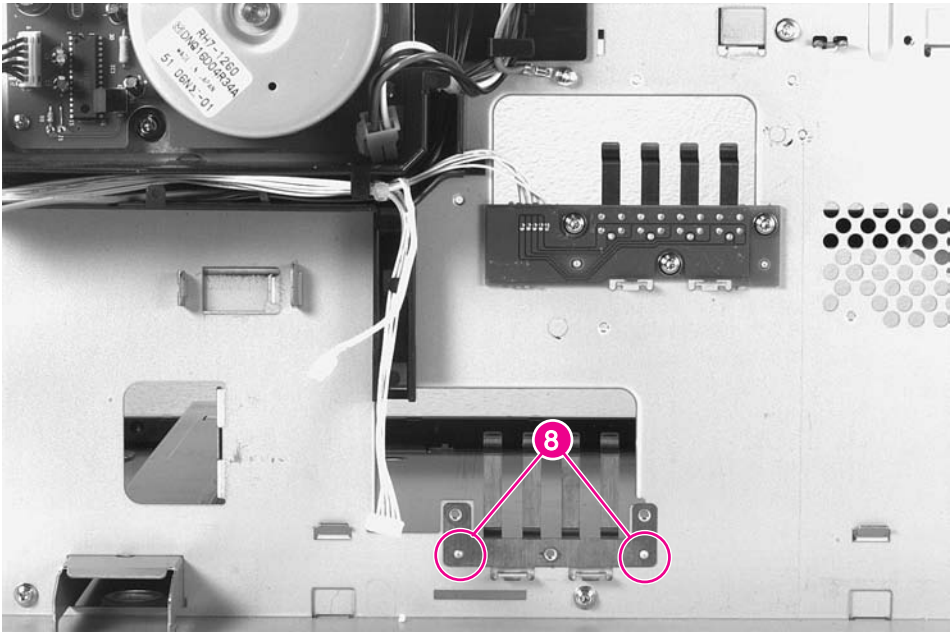

Figure 6-50 Paper Size PCA (3 of 3)

To Reinstall:

Make sure that the actuating fingers are aligned with the locating pins (figure 6-50, callout 8).

High Voltage Power Supply (HVPS)

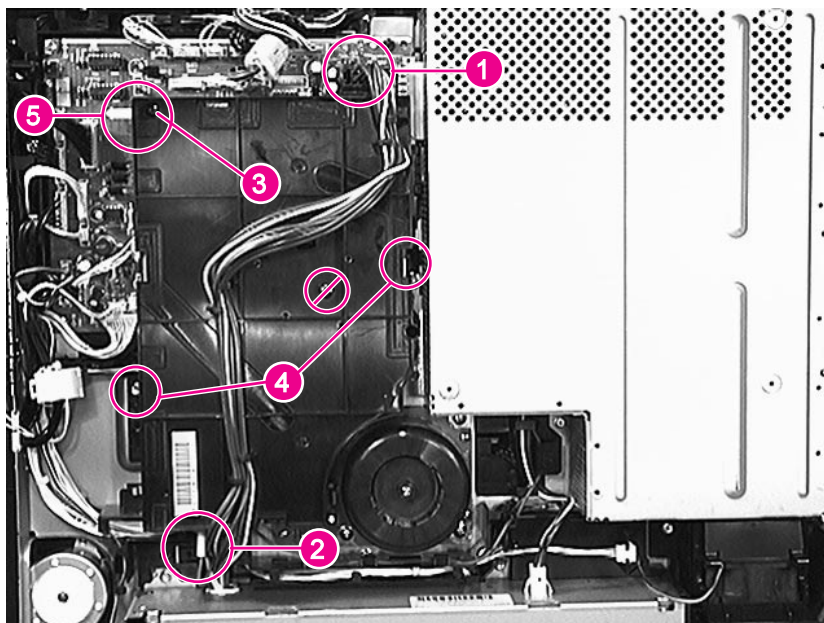

Figure 6-51 High Voltage Power Supply

- 1 Remove the back cover (see figure 6-6 on page 219).
- 2 Unplug the cable from the LVPS to the DC Controller PCA (figure 6-51, callout 1), and move it out of the way.
- 3 Unplug the connector from the bottom of the HVPS (figure 6-51, callout 2).

Note

Do NOT remove the screw indicated in Figure 6-51, beneath the null symbol.

- 4 Remove 1 self-tapping screw (figure 6-51, callout 3) and 2 screws (figure 6-51, callout 4).

To Reinstall:

Make sure that the plastic alignment pin (figure 6-51, callout 5), the connector pins, and the high voltage contacts are properly aligned before replacing the screws.

Low Voltage Power Supply (LVPS)

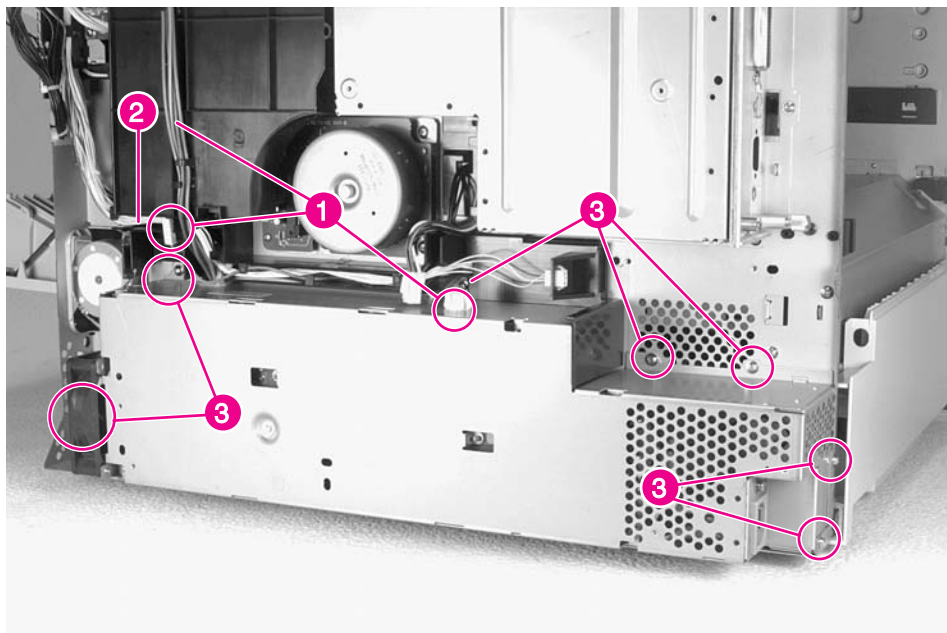

Figure 6-52 Low Voltage Power Supply

- 1 Remove the Formatter Assembly (see figure 6-35 on page 251).
- 2 Remove the back cover (see figure 6-6 on page 219).
- 3 Remove Fan 3 and its Housing Assembly (see figure 6-22).
- 4 Unplug 3 LVPS connectors (figure 6-52, callout 1).
- 5 Unplug the LVPS fan (FM1) cable from the DC Controller (figure 6-52, callout 2).
- 6 Remove 7 screws (figure 6-52, callout 3).

Registration Assembly

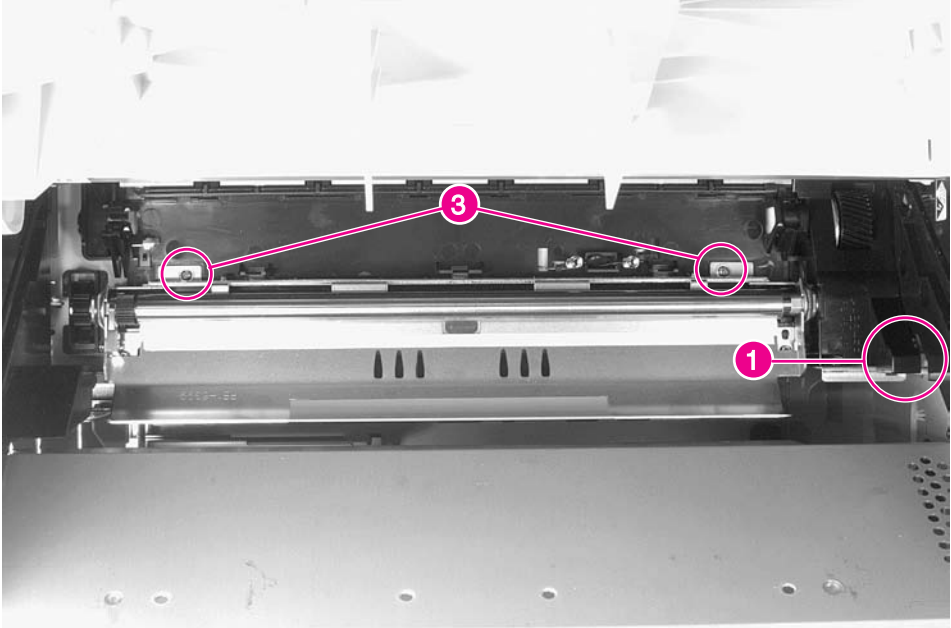

Figure 6-53 Registration Assembly (1 of 3)

- 1 Open the top cover door and remove the toner cartridge.
- 2 Remove the Transfer Roller Assembly (see figure 6-62 on page 282).
- 3 Remove the Main Gear Train Shield. Release the retainer clip (figure 6-53, callout 1), and lift the forward end up.
- 4 Remove 2 screws at rear of assembly (figure 6-53, callout 3).

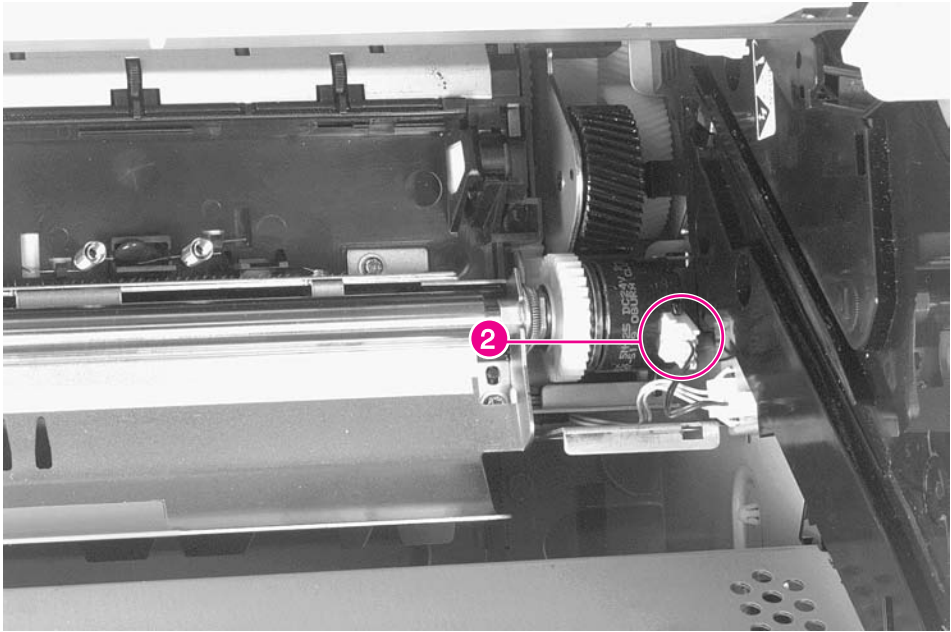

Figure 6-54 Registration Assembly (2 of 3)

- 5 Unplug the clutch cable from the clutch on the right end of the Registration Assembly (figure 6-54, callout 2).

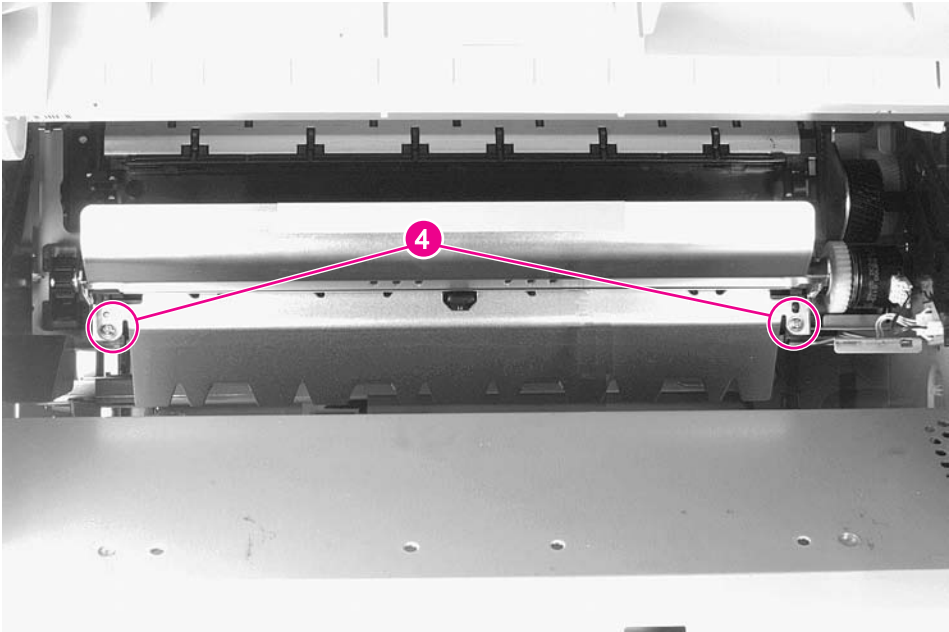

Figure 6-55 Registration Assembly (3 of 3)

- 6 Lift the registration guide and remove 2 screws at the front of the assembly (figure 6-55, callout 4).

To Reinstall:

- 1 Lift the registration guide, and place the Registration Assembly into position.
- 2 Lift the registration guide and make sure that the locator pin near the right screw is properly positioned.
- 3 Make sure that the grounding strap is under the left screw.
- 4 Be sure to connect the clutch cable connector.
- 5 After replacing the 4 screws, replace the Main Gear Train Shield. Tilt the top outward, reinstall the lower tabs in place, and snap the cover down into position.

Tray 1 Feed Roller and Separation Pad

Feed Roller

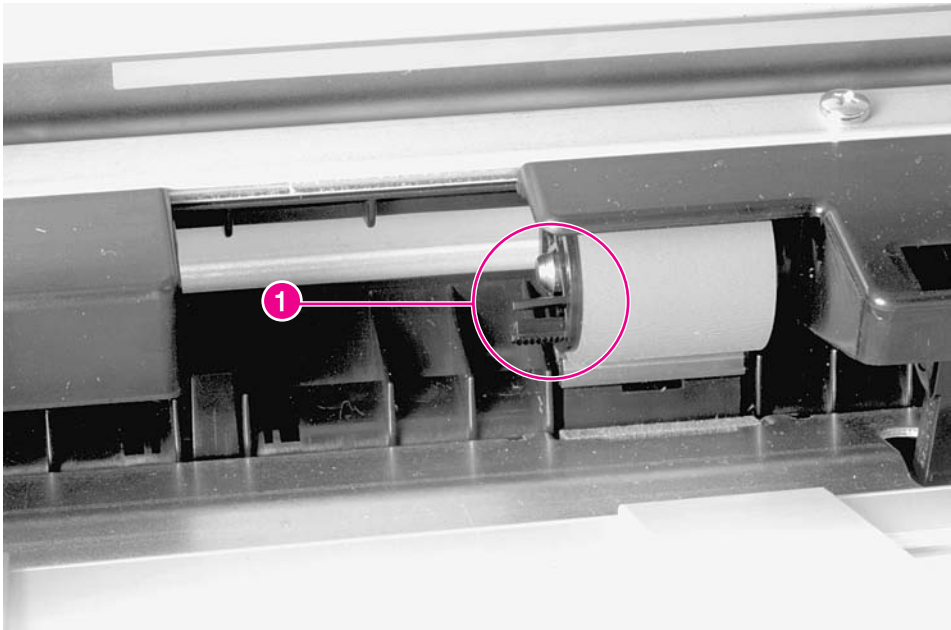

Figure 6-56 Tray 1 Feed Roller

- 1 Open the Tray 1 door, and remove the plastic shield.
- 2 Pinch the retainer tabs together (figure 6-56, callout 1), and slide the roller to the left off of the shaft.

Tray 1 Separation Pad

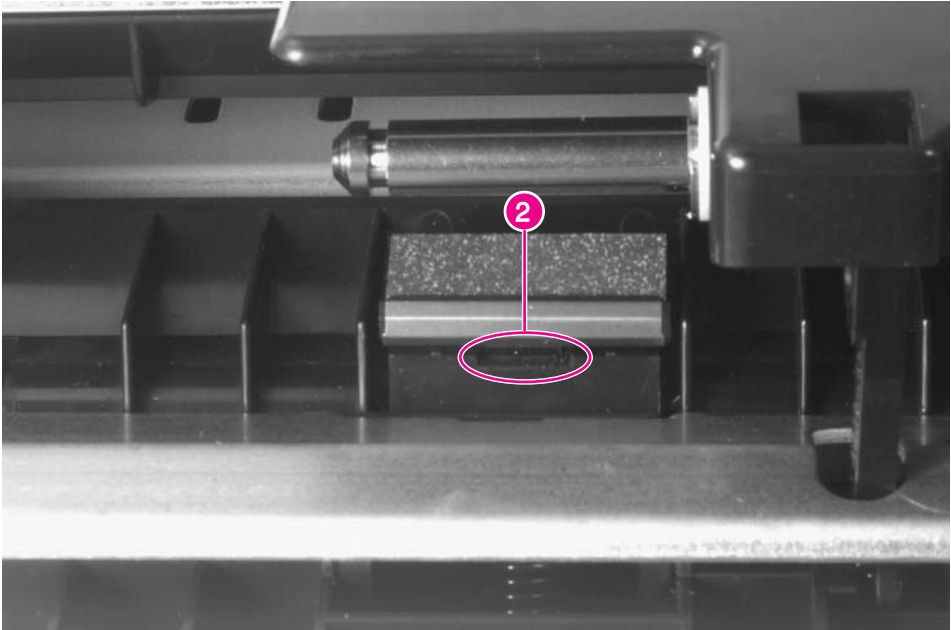

Figure 6-57 Tray 1 Separation Pad

- 1 Open the Tray 1 door, and remove the Feed Roller.
- 2 Insert a flat-bladed screwdriver into the slot (figure 6-57, callout 2), and carefully pry the separation pad upwards out of its retaining notches.

To Reinstall:

Make sure the metal edge of the Separation Pad faces forward.

Tray 2 and 3 Pickup, Feed, and Separation Rollers

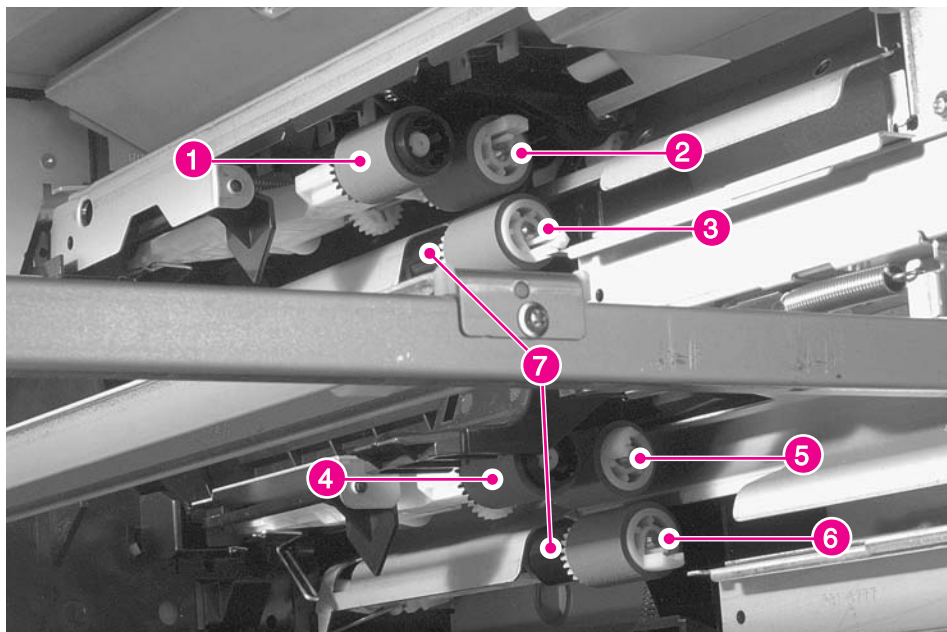

Figure 6-58 Tray 2 and 3, Pickup, Feed, and Separation Rollers

There are three rollers for each tray: the Pickup Roller, the Feed Roller, and the Separation Roller. The Feed and Separation Rollers are interchangeable with each other and between trays. The Pickup Rollers are interchangeable between trays.

- Tray 2 Pickup Roller: figure 6-58, callout 1
- Tray 2 Feed Roller: figure 6-58, callout 2
- Tray 2 Separation Roller: figure 6-58, callout 3
- Tray 3 Pickup Roller: figure 6-58, callout 4
- Tray 3 Feed Roller: figure 6-58, callout 5
- Tray 3 Separation Roller: figure 6-58, callout 6

Note

The Feed and Separation rollers have protruding tabs, and the pickup rollers have recessed retaining tabs. Be careful not to lose the plastic torque limiters located behind the Separation Rollers (figure 6-58, callout 7).

- 1 Remove trays. From inside the tray cavity, remove the rollers by pinching the retainer tabs together and sliding the roller off the shaft.

Paper Input Unit Sensor (PS2)

- 1 Remove the following components in the order listed:
 - Toner Cartridge
 - Trays 2 and 3
 - Transfer Roller (see figure 6-62 on page 282)
 - Registration Assembly (see figure 6-54 on page 272)
 - Front Cover (see figure 6-7 on page 220)
 - Tray 1 Assembly (see figure 6-26 on page 241)
 - Right Lower Door Assembly (see figure 6-16 on page 231)

Note

The sensor retaining tabs are released from above, and the sensor is removed and replaced from below.

- 2 Refer to the following page for the removal and reinstallation procedure for the PS2 sensor.

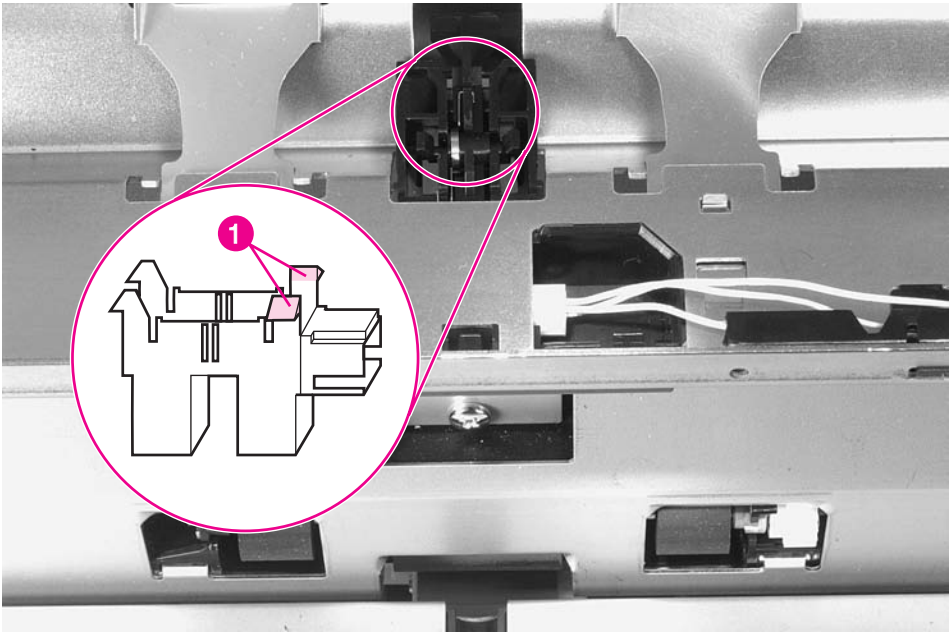

Figure 6-59 Paper Input Unit Sensor (PS2)

- 3 Release the retaining tabs (figure 6-59, callout 1) on the right end of the sensor, and rotate the sensor down to free the tabs on the left end.
- 4 Unplug the connector from the sensor.

To Reinstall:

- 1 Plug in the connector before reinstalling.
- 2 Holding the sensor flag out of the way, first hook the tabs on the left end in first. Snap the right end of the sensor upward into place.

Registration Sensor (PS1)

- 1 Remove the following components in the order listed:
 - Toner Cartridge
 - Trays 2 and 3
 - Transfer Roller (see figure 6-62 on page 282)
 - Registration Assembly (see figure 6-54 on page 272)
 - Front Cover (see figure 6-7 on page 220)
 - Tray 1 Assembly (see figure 6-26 on page 241)
 - Right Lower Door Assembly (see figure 6-16 on page 231)
 - Paper Input Unit (see figure 6-42 on page 260)

Note

The sensor retaining tabs are released from above, and the sensor is removed and replaced from inside the Paper Input Unit cavity.

- 2 Follow the procedure on the following page to remove and reinstall the PS1 sensor.

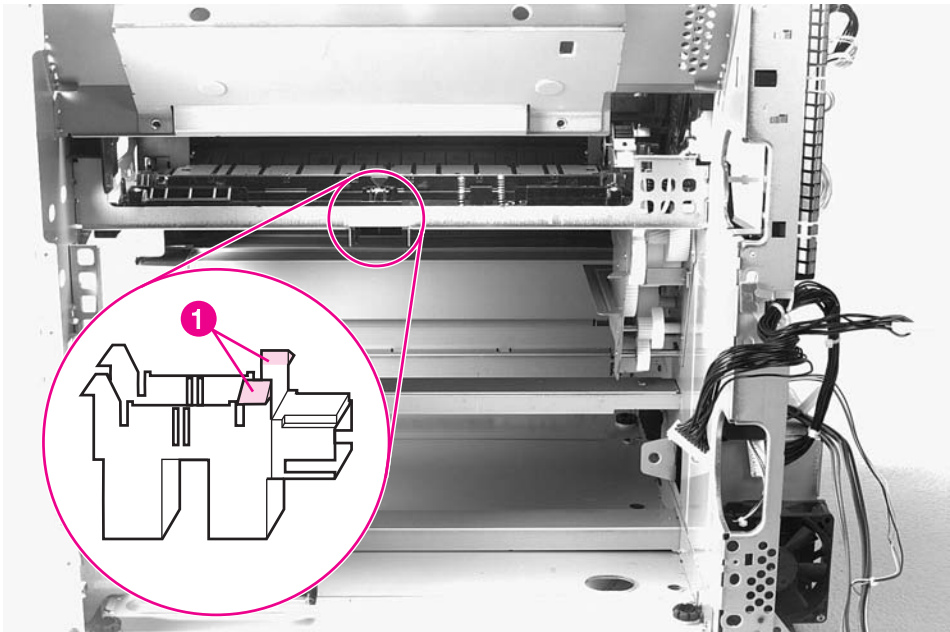

Figure 6-60 Registration Sensor (PS1)

- 3 Release the retaining tabs (figure 6-60, callout 1) on the right end of the sensor and rotate the sensor down to free the tabs on the left end of the sensor.
- 4 Unplug the connector from the sensor.

To Reinstall:

- 1 Plug in the connector.
- 2 Holding the sensor flag out of the way, first hook the tabs on the left end in first. Snap the right end of the sensor upward into place.

Face-up Solenoid Assembly (SL3)

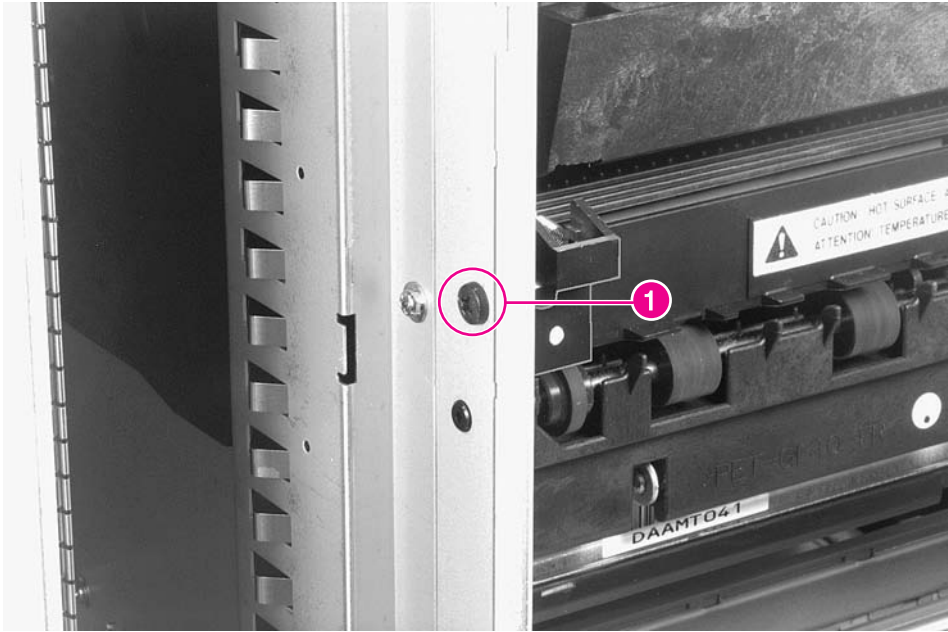

Figure 6-61 Face-up Solenoid Assembly, SL3

- 1 Remove the top cover (see figure 6-10 on page 223).
- 2 Remove the Delivery Unit (see figure 6-12 on page 226).
- 3 Remove 1 self-tapping screw (figure 6-61, callout 1).

CAUTION

Be careful not to damage the plastic arm when removing the assembly.

- 4 Pull the forward end of the assembly away from the chassis to clear the locating pin, and slide it forward to clear two retaining tabs.

Transfer Roller Assembly

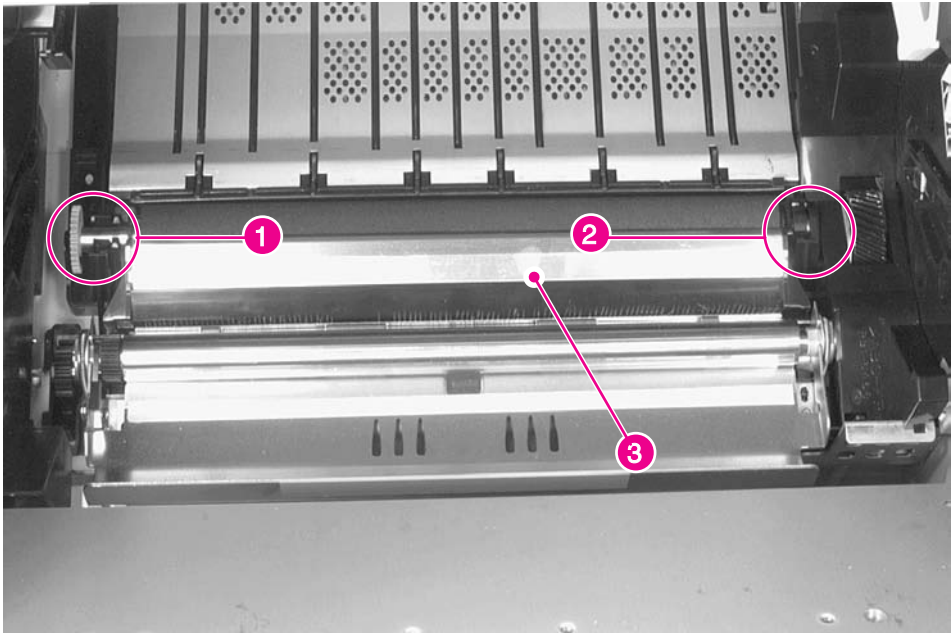

Figure 6-62 Transfer Roller Assembly

CAUTION

Handle the Transfer Roller from the ends only. Do not touch the surface of the Transfer Roller. Skin oils will affect its electrical characteristics, resulting in poor image transfer.

- 1 Open the top cover door, and remove the toner cartridge.
- 2 Grasp the gear (figure 6-62, callout 1) on the left end, and carefully lift upward just enough to clear the retainer clip.
- 3 Slide the Transfer Roller Assembly to the left to release the shaft on the right end (figure 6-62, callout 2).

To Reinstall:

- 1** Place the right end of the shaft into its retaining cavity.
- 2** Hold the Transfer Roller wiper up (figure 6-62, callout 3) and slide the assembly to the right until the gear on the left end is in position.
- 3** Carefully press the left end of the shaft into the retainer clip.
- 4** Press the Transfer Roller wiper down (figure 6-62, callout 3) until the retaining clips snap into place.

Tray 2 and 3 Assemblies

Note

The paper trays are mechanically aligned to the printer chassis at the factory. If you are replacing Tray 2 or Tray 3 with a tray other than the original factory installed unit, you may have to adjust the new tray. For details, see “Tray Adjustment Procedure” on page 116.

- 1 Open the tray, and pull it out to the stop.
- 2 Press the colored tab at the right side of the tray, and continue to pull the tray slightly upwards and out of the chassis.

To Reinstall:

- 1 Align the left rear corner of the tray and the locating track at the lower rear center of the tray with their respective guides, and insert the tray no more than two inches into the chassis.
- 2 Carefully lift up on the outer end of the tray while pulling the tray stop mechanism, located at the right rear of the tray opening, out and over the tray roller and guide assembly.
- 3 Carefully slide the tray into the printer until it latches into place.

2000-sheet Input Tray Removal and Replacement

WARNING!

For the procedures in this section, the printer and all paper-handling devices must be unplugged. Before attempting to service the 2000-sheet Input Tray, unplug the power cord from the power source; otherwise, severe injury may result.

The printer and paper-handling devices may have sharp edges that could cause injury.

Note

Reinstallation is generally the reverse of the removal process. Carefully follow any additional instructions provided under "To Reinstall."

Orientation - - - - -	286
Front Cover - - - - -	287
Back Cover- - - - -	288
Left Cover - - - - -	289
Right Cover - - - - -	290
Main Drive Assembly - - - - -	291
Paper Tray - - - - -	293
Main Cable Harness - - - - -	294
Controller PCA - - - - -	296
Front LED PCA Assembly - - - - -	298
Pickup Assembly - - - - -	300
Power Supply - - - - -	302
Pickup, Feed, and Separation Rollers - - - - -	304
Paper Quantity Switch Assembly - - - - -	306
Paper Size Switch Assembly - - - - -	306
Vertical Transfer Unit (VTU)- - - - -	308
Tension Springs - - - - -	310
Locating Pins- - - - -	311
Casters and Stabilizing Feet - - - - -	312
Adjustable Foot- - - - -	313

Orientation

Figure 6-63 shows the orientation of the 2000-sheet Input Tray as it is referred to in this section.

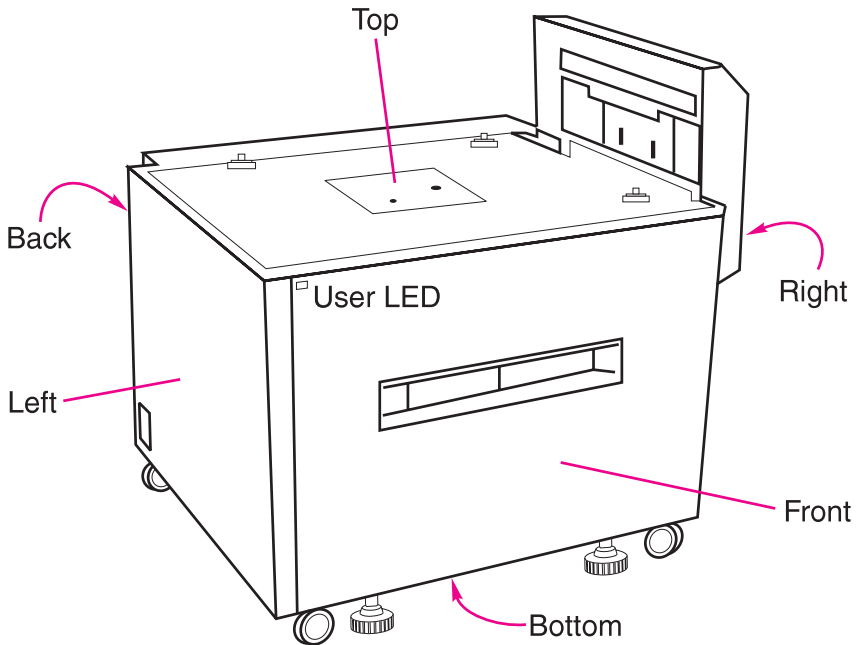

Figure 6-63 2000-sheet Input Tray Orientation

To remove the 2000-sheet Input Tray from the printer, see page 207.

Front Cover

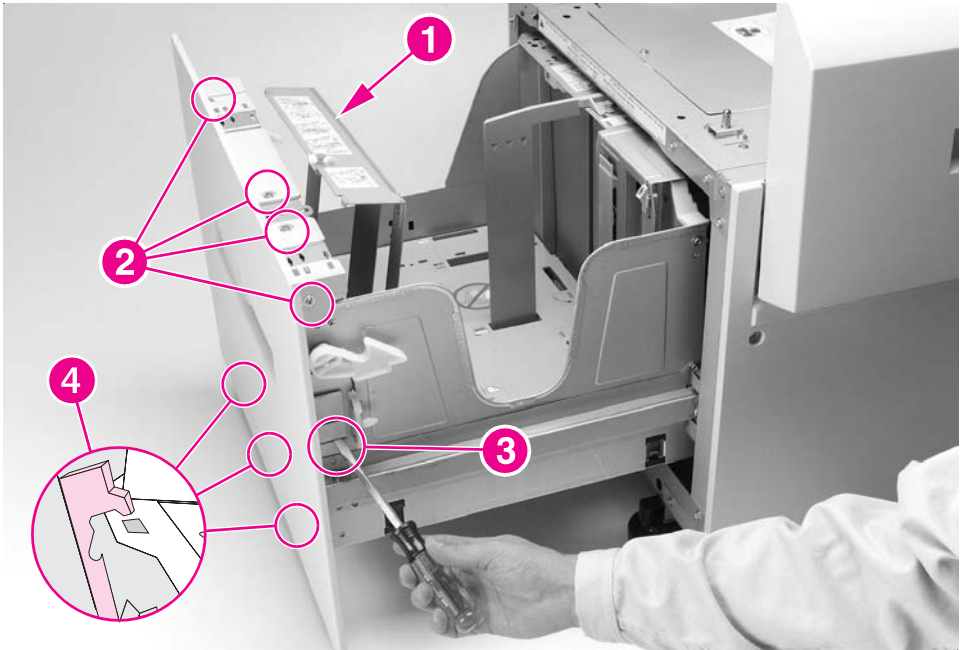

Figure 6-64 2000-sheet Input Tray Front Cover

- 1 Open the paper tray on the 2000-sheet Input Tray to the stops (figure 6-64).
- 2 Remove the Paper Limit Back Plate from the paper tray (callout 1).
- 3 Remove the 4 screws in the front of the tray: 3 screws at the top of the tray and 1 screw on the front-right side of the tray (callout 2).
- 4 Using a flat-blade screwdriver, release the plastic retaining tabs at the left- and right-front sides of the tray (callout 3).
- 5 Carefully lift up on the Front Cover, and then pull it out to release the plastic retaining tabs that secure the bottom of the Front Cover to the tray chassis (callout 4).

To Reinstall:

- 1 Replace all the plastic retaining tabs properly (callout 4).
- 2 Reinstall the front adjustable plate, and configure it properly (callout 1). Reinstall the tray size labels.

Back Cover

- 1 Make sure that the power cord for the 2000-sheet Input Tray is unplugged from the power source.
- 2 Remove the 4 screws that secure the Back Cover of the 2000-sheet Input Tray to the chassis: 1 screw on each corner (figure 6-65, callout 1).
- 3 Pull the Back Cover out from the chassis.

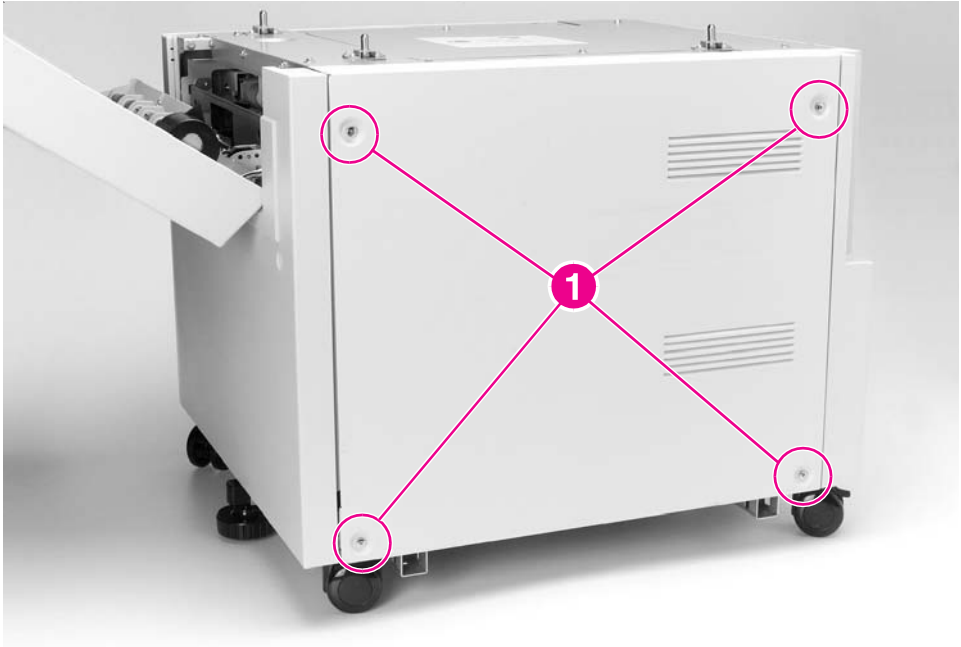

Figure 6-65 2000-sheet Input Tray Back Cover

To Reinstall:

- 1 Insert the tab on the lower-left corner into its alignment slot.

Left Cover

- 1 Unplug the power cord and the C-link interface cables from the 2000-sheet Input Tray.
- 2 Remove the 2 screws that are located at the top of the 2000-sheet Input Tray's Left Cover: 1 screw near each corner (figure 6-66, callout 1).
- 3 Remove the Left Cover from the unit:
 - a Pull out on the top of the Left Cover, and then lift up on the Left Cover's right side to clear the retaining tabs that are along the Left Cover's bottom edge (callout 2).
 - b Pull out on the Left Cover's lower-left corner to release the plastic retainer tab that secures that corner of the cover to the chassis (callout 3).

To Reinstall:

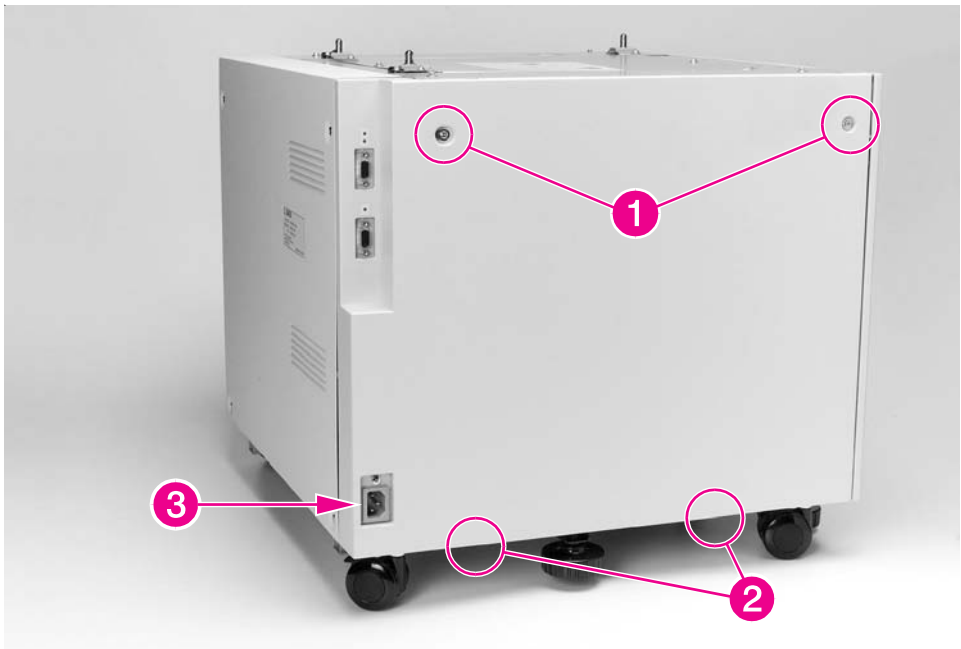

Figure 6-66 2000-sheet Input Tray Left Cover

- 1 Replace the left side of the Left Cover first (callout 3).
- 2 Tilt the right side of the Left Cover down and toward the chassis to place the lower retaining tabs over the chassis rail (callout 2).

Right Cover

- 1 Remove the Vertical Transfer Unit (VTU) from the 2000-sheet Input Tray (see figure 6-78).
- 2 Remove the 2 screws that are located near the middle of the 2000-sheet Input Tray's Right Cover: 1 screw on each side (figure 6-67, callout 1).
- 3 Using a flat-blade screwdriver, release the plastic retaining tab that secures the Right Cover's upper-left corner to the chassis (figure 6-67, callout 2).
- 4 To remove the Right Cover, carefully pull out on the top of the cover while lifting it upward to clear the retaining tabs that are along the cover's bottom edge.

To Reinstall:

- 1 Place the retaining tabs that are along the Right Cover's bottom edge over the chassis rail.
- 2 Reinstall the VTU (see figure 6-78).

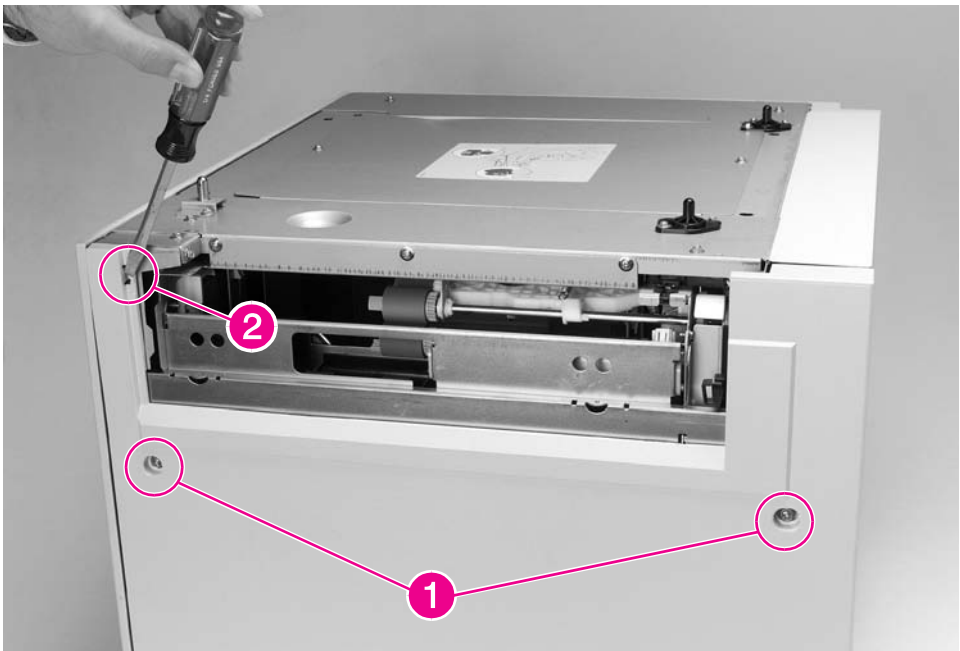

Figure 6-67 2000-sheet Input Tray Right Cover

Main Drive Assembly

- 1 Remove the Back Cover from the 2000-sheet Input Tray (see figure 6-65).

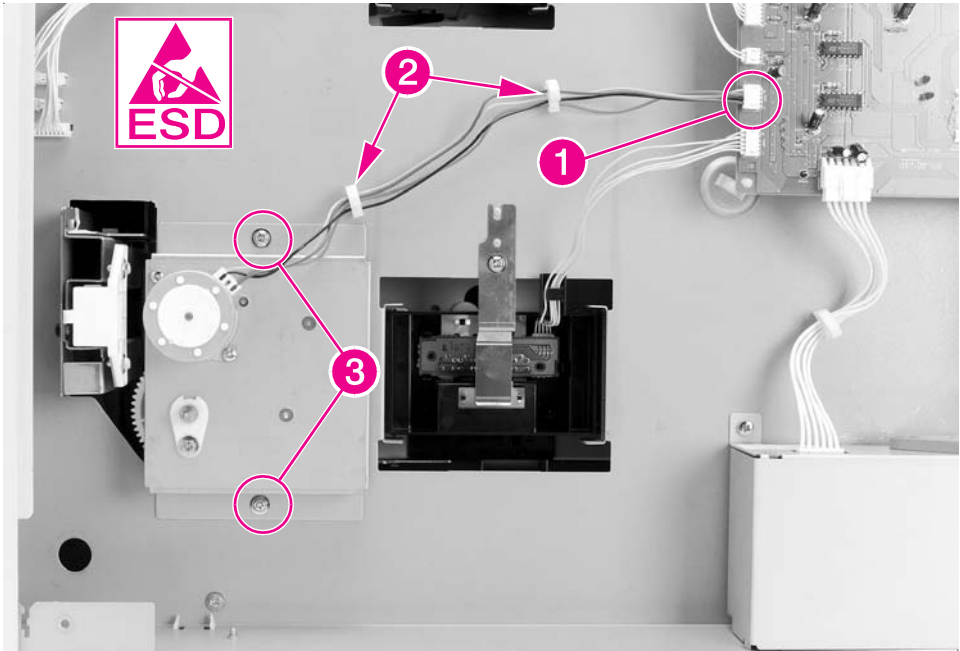

Figure 6-68 2000-sheet Input Tray Main Drive Assembly

- 2 Locate the cable that runs from the Main Drive Assembly on the 2000-sheet Input Tray to the unit's Controller PCA. Disconnect the cable from the J206 connector on the Controller PCA (figure 6-68, callout 1).
- 3 Release the cable from the 2 cable clips that hold the cable to the chassis (figure 6-68, callout 2).
- 4 Remove the 2 screws that connect the Main Drive Assembly to the chassis: 1 screw on top of the Main Drive Assembly and 1 screw on the bottom (figure 6-68, callout 3).
- 5 Pull the Main Drive Assembly away from the chassis.
- 6 Inspect the Paper Deck Drive Bushing on the Main Drive Assembly. If the bushing is damaged, it can be replaced without replacing the whole drive assembly.

Note

Reassembly notes are on the next page.

To Reinstall:

- 1 Reroute the cable through the cable clips (figure 6-68, callout 2) and reconnect the cable to the J206 connector on the Controller PCA (figure 6-68, callout 1).

Paper Tray

- 1 Open the paper tray on the 2000-sheet Input Tray and remove any unused paper.
- 2 Remove the Vertical Transfer Unit (VTU) from the 2000-sheet Input Tray (see figure 6-78).
- 3 Remove the Left and Right Covers from the 2000-sheet Input Tray (see figure 6-66 and figure 6-67).

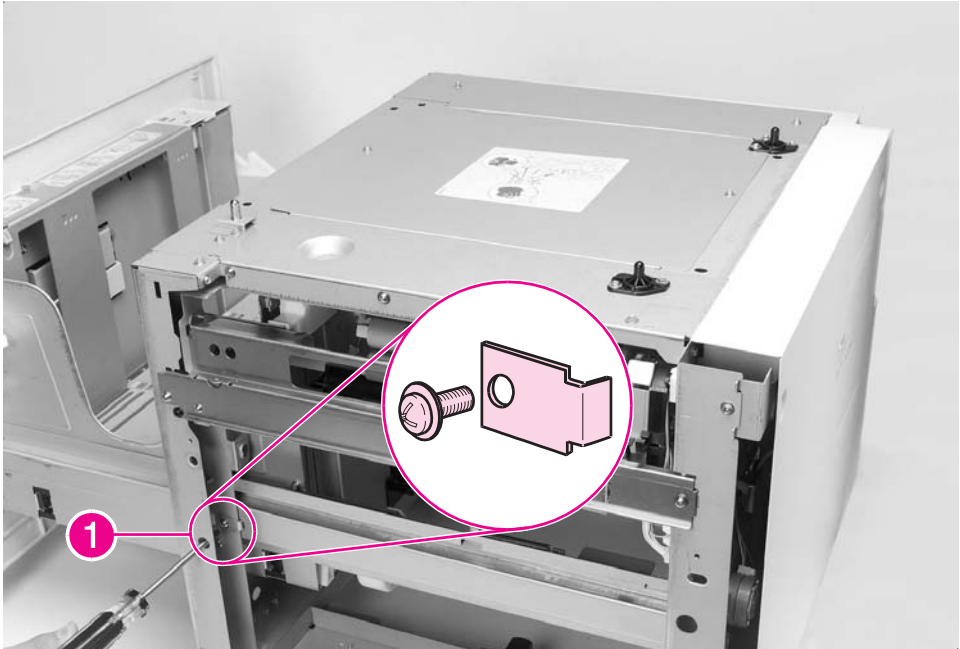

Figure 6-69 2000-sheet Input Tray Paper Tray

- 4 Remove the 2 screws and metal retaining tabs from the sides of the unit's chassis: 1 screw and retaining tab on each side of the chassis (figure 6-69, callout 1).
- 5 Slide the paper tray straight out of the chassis while carefully supporting the rear of the paper tray.

To Reinstall:

- 1 Make sure that the retaining tabs are tightly secured to the unit's chassis (figure 6-69, callout 1).
- 2 After replacing the tray, print a test page. If the print is too close to the paper's edge, adjust the tray.

Main Cable Harness

- 1** Remove the Back Cover from the 2000-sheet Input Tray (see figure 6-65).
- 2** Locate and disconnect the 6 cable connectors that connect the Main Cable Harness to the Controller PCA on the 2000-sheet Input Tray (figure 6-70, callout 1).
- 3** Locate and disconnect the 5 cable connectors that connect the Main Cable Harness to the unit's chassis (callout 2).
- 4** Release the cable harness from the 4 cable clips that hold the harness to the unit's chassis (callout 3).

To Reinstall:

- 1** Properly replace all 11 cable harness connectors (callouts 1 and 2).
- 2** Reattach the harness to the 4 cable clips that hold the harness to the unit's chassis (callout 3).

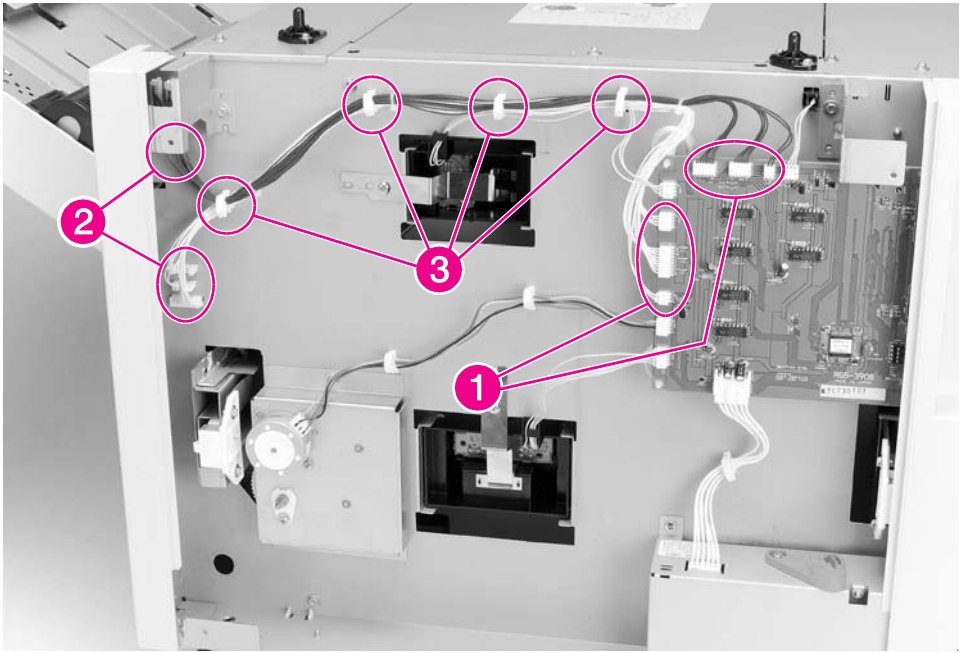

Figure 6-70 2000-sheet Input Tray Main Cable Harness

Controller PCA

- 1 Remove the Back and Left Covers from the 2000-sheet Input Tray (see figure 6-65 and figure 6-66).

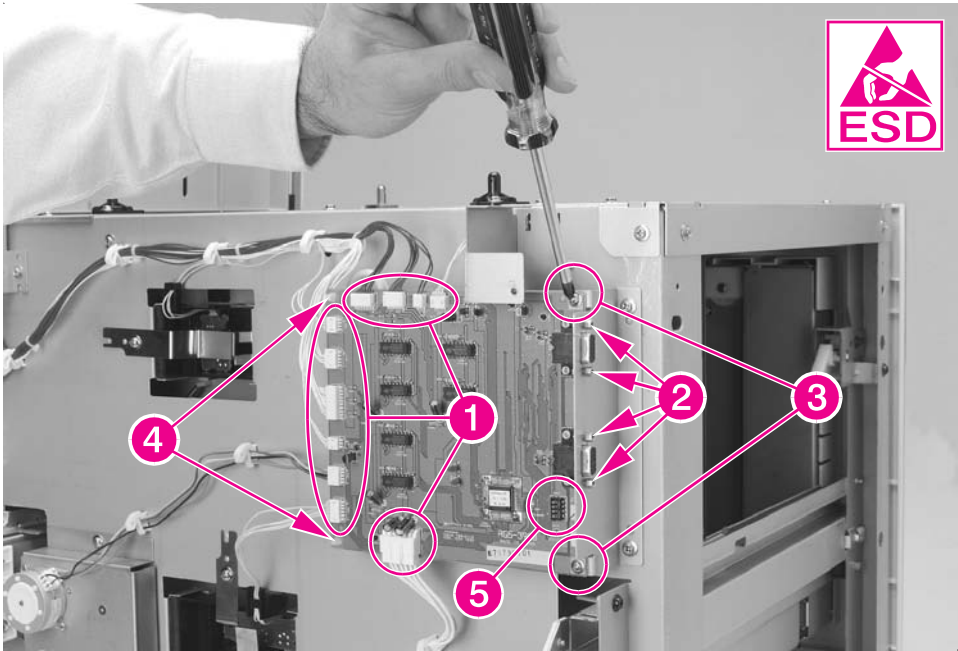

Figure 6-71 2000-sheet Input Tray Controller PCA

- 2 Disconnect the 11 cables from the Controller PCA on the 2000-sheet Input Tray (figure 6-71, callout 1).
- 3 Remove the 4 hex screws that secure the 2 C-link cable connectors to the metal base (callout 2).
- 4 Remove the 2 screws that secure the right side of the Controller PCA to the metal base (callout 3).
- 5 Release the 2 plastic retaining posts that secure the left side of the Controller PCA to the metal base (callout 4), and then pull the Controller PCA out from the unit's chassis.

To Reinstall:

- 1** Seat the Controller PCA firmly onto the plastic retaining posts that secure the left side of the Controller PCA to the metal plate on the chassis (callout 4).
- 2** Properly reconnect all 11 cables to the Controller PCA (callout 1).
- 3** Make sure that the DIP switches on the Controller PCA are in the normal setting (off) (callout 5). (See table 7-34 on page 619.)

Front LED PCA Assembly

- 1 Open the paper tray on the 2000-sheet Input Tray halfway to the stops.
- 2 On the upper-left corner of the front of the unit's chassis, locate and remove the 1 screw that secures the LED PCA Assembly to the chassis (figure 6-72, callout 1).
- 3 Reach behind the LED PCA Assembly and pull it away from the chassis.
- 4 To remove the LED PCA from the cable connector, release the 3 plastic retaining tabs that secure the LED PCA to the connector (figure 6-72, callout 2).
- 5 Pull the LED PCA from the connector.

To Reinstall:

- 1 Reconnect the LED PCA to the connector (callout 2).

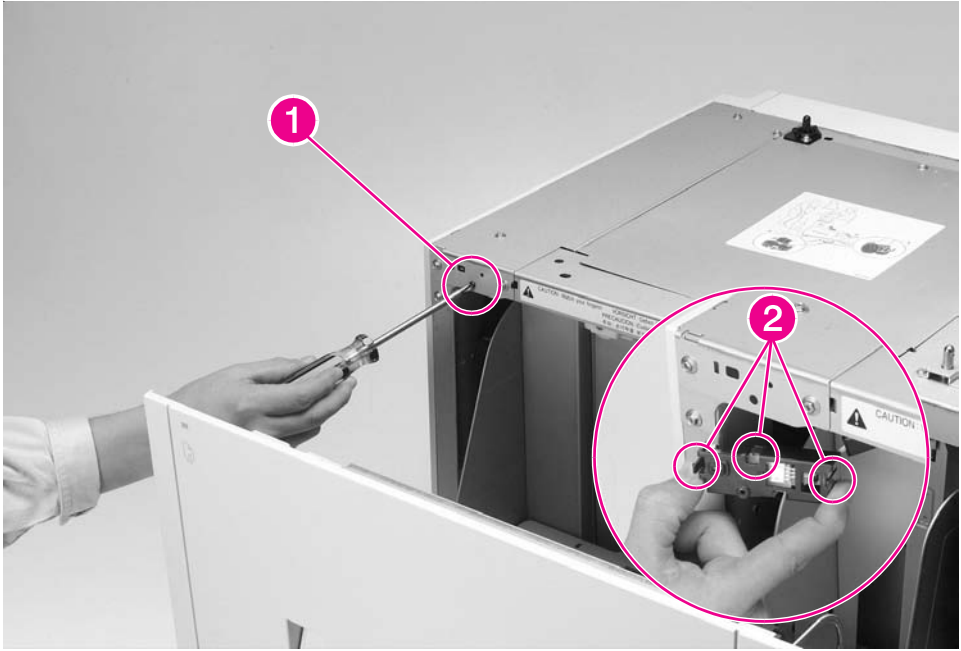

Figure 6-72 2000-sheet Input Tray Front LED PCA

Pickup Assembly

- 1 Remove the Vertical Transfer Unit (VTU) from the 2000-sheet Input Tray (see figure 6-78).
- 2 Remove the Right Cover from the 2000-sheet Input Tray (see figure 6-67).
- 3 Open the paper tray on the 2000-sheet Input Tray to the stops.

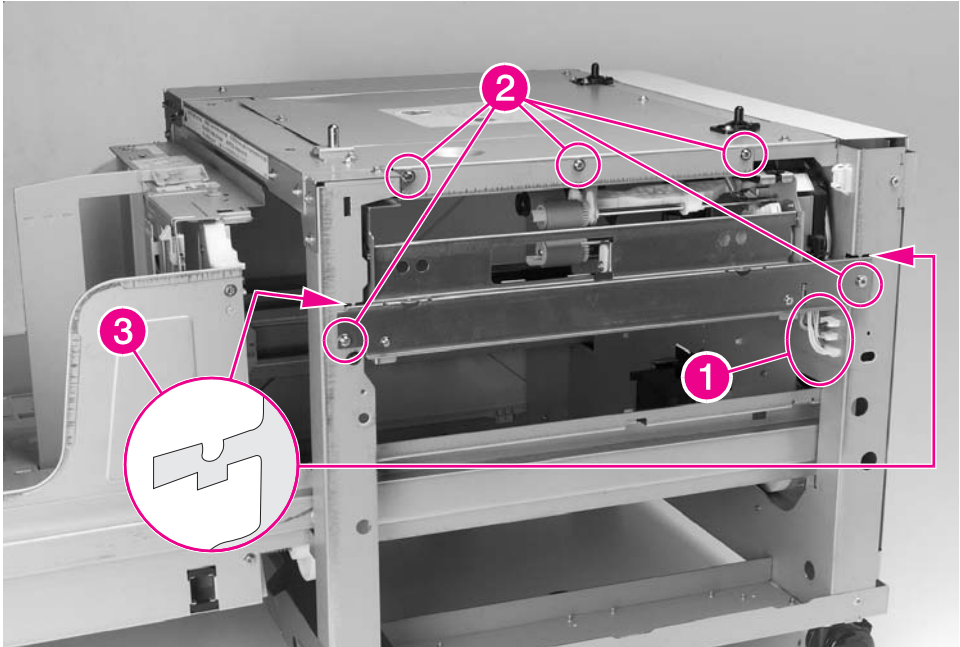

Figure 6-73 2000-sheet Input Tray Pickup Assembly

- 4 Disconnect the 3 cables that are located at the bottom-right side of the Pickup Assembly (figure 6-73, callout 1).
- 5 Remove the 5 screws that secure the Pickup Assembly to the unit's chassis: 3 screws along the top, and 1 screw on each side (callout 2).
- 6 Slide the Pickup Assembly straight out of the chassis.

To Reinstall:

- 1** Make sure that the paper tray is open to easily slide the Pickup Assembly into the chassis.
- 2** Make sure that the Pickup Assembly is seated properly in the locating slots (callout 3).
- 3** Reconnect the 3 cables that are located at the bottom-right side of the Pickup Assembly (callout 1).

Power Supply

- 1 Remove the Back and Left Covers from the 2000-sheet Input Tray (see figure 6-65 and figure 6-66).

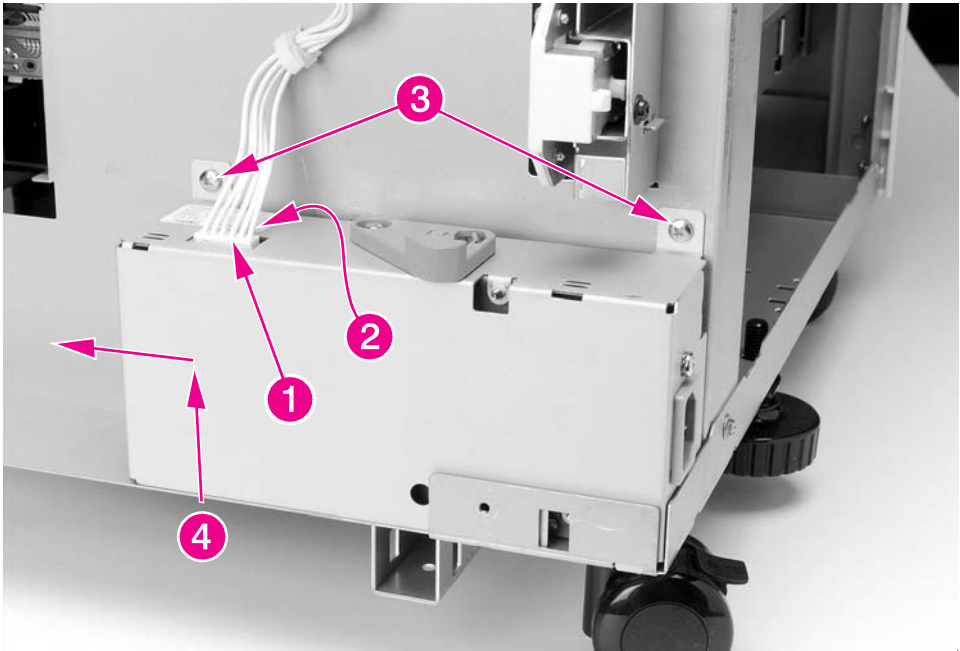

Figure 6-74 2000-sheet Input Tray Power Supply

- 2 Locate the cable that runs from the Controller PCA on the 2000-sheet Input Tray to the unit's Power Supply (Figure 6-74, callout 1). Disconnect the cable from the Power Supply by pushing on the retaining tab that is located behind the cable connector (callout 2).
- 3 Remove the 2 screws that secure the Power Supply to the chassis (callout 3).
- 4 Lift the Power Supply upward to clear the locating tabs underneath, and then slide the Power Supply to the left to free it from the chassis (callout 4).

To Reinstall:

- 1** Carefully align the locating tabs so that they are positioned correctly.
- 2** Reconnect the cable that runs from the Power Supply to the Controller PCA on the 2000-sheet Input Tray (callout 1). The cable connector is seated properly when it clicks.

Pickup, Feed, and Separation Rollers

Three rollers in the 2000-sheet Input Tray pick up paper and feed it to the printer:

- The Pickup Roller is the upper-forward roller (Figure 6-75, callout 1).
- The Feed Roller is the upper-rear roller (callout 2).
- The Separation Roller is the lower roller (callout 3).

Note

The Feed and Separation Rollers in the 2000-sheet Input Tray are interchangeable with each other and with the Feed and Separation Rollers in trays 2 and 3 on the printer. Additionally, the Pickup Roller in the 2000-sheet Input Tray is interchangeable with the Pickup Rollers in trays 2 and 3 on the printer.

The Feed and Separation Rollers have protruding retaining tabs that secure the rollers to their respective shafts. The retaining tab on the Pickup Roller is recessed.

The Feed and Separation Rollers must be replaced every 350,000 images. The two rollers are included in the printer maintenance kit C3914A (110V), C3915A (220V). The kit contains all the necessary parts for the required user maintenance procedure.

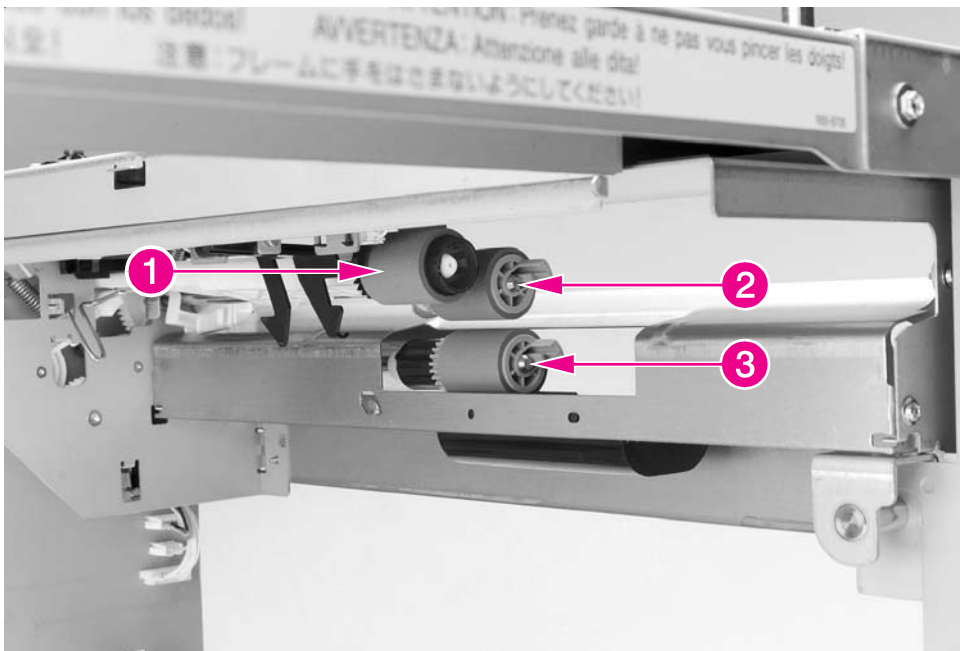

Figure 6-75 2000-sheet Input Tray Rollers: Pickup, Feed, and Separation

To Remove the Feed and Separation Rollers

- 1 Open the Vertical Transfer Unit (VTU) on the 2000-sheet Input Tray.
- 2 Locate the rollers inside the tray cavity. To remove a roller, pinch the retainer tabs together and slide the roller off the shaft. Remove the Feed Roller (upper-rear roller) first. Then remove the Separation Roller (lower roller).

To Remove the Pickup Roller

- 1 Open the paper tray on the 2000-sheet Input Tray to the stops.
- 2 Remove the Left Cover from the 2000-sheet Input Tray (see figure 6-66 on page 289).
- 3 Locate the Pickup Roller inside the tray cavity.
- 4 Pinch the recessed retainer tab on the roller, and slide the roller off the shaft.

Note

Reassembly notes are on the next page.

To Reinstall:

- 1 If all three rollers were removed, reinstall the Pickup Roller first (callout 1).
- 2 When reinstalling the Feed and Separation Rollers, install the Separation Roller (lower roller) first (callout 3). Then install the Feed Roller (upper-rear roller) (callout 2).
- 3 When installing a roller, listen for a click. It signals that the roller is secured onto the shaft.

Paper Quantity Switch Assembly

- 1 Remove the Back Cover from the 2000-sheet Input Tray (see figure 6-65 on page 288).
- 2 Locate the cable that runs from the Paper Quantity Switch Assembly on the 2000-sheet Input Tray to the unit's Controller PCA. Disconnect the cable from the Controller PCA (J205 connector), and then free the cable from the cable clips that secure it to the chassis (Figure 6-76, callout 1).
- 3 Remove the 1 screw (callout 2) and the metal retaining spring (callout 3) that hold the switch assembly in place.
- 4 Pull the switch assembly out of its cavity (Figure 6-77, callout 1).

To Reinstall:

- 1 When reinstalling the metal retaining spring that holds the switch assembly in place (Figure 6-76, callout 2), seat the retaining spring onto the locating pins that are on the chassis.
- 2 Reconnect the switch assembly's cable to the J205 connector on the Controller PCA (Figure 6-76, callout 1).

Paper Size Switch Assembly

- 1 Remove the Back Cover from the 2000-sheet Input Tray (see Figure 6-65).
- 2 Locate the cable that runs from the Paper Size Switch Assembly on the 2000-sheet Input Tray to the unit's Controller PCA. Disconnect the cable from the Controller PCA (J204 connector) (Figure 6-76, callout 4).
- 3 Remove the 1 screw (callout 5) and the metal retaining spring (callout 6) that hold the switch assembly in place.
- 4 Pull the switch assembly out of its cavity (Figure 6-77, callout 2).

To Reinstall:

- 1 When reinstalling the metal retaining spring that holds the switch assembly in place (Figure 6-76, callout 5), seat the retaining spring onto the locating pins on the chassis.
- 2 Reconnect the switch assembly's cable to the J204 connector on the Controller PCA (Figure 6-76, callout 4).

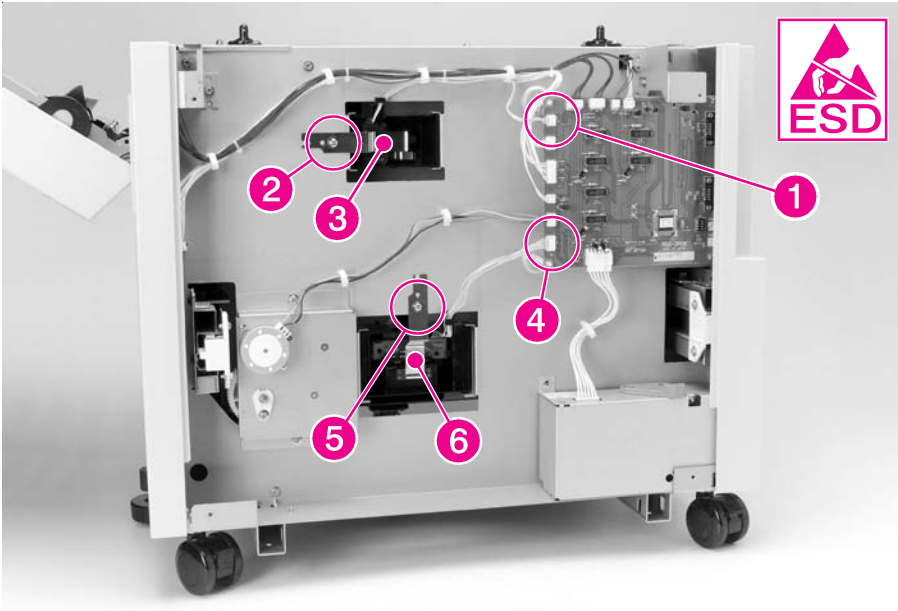

Figure 6-76 2000-sheet Input Tray Paper Size and Paper Quantity Switch

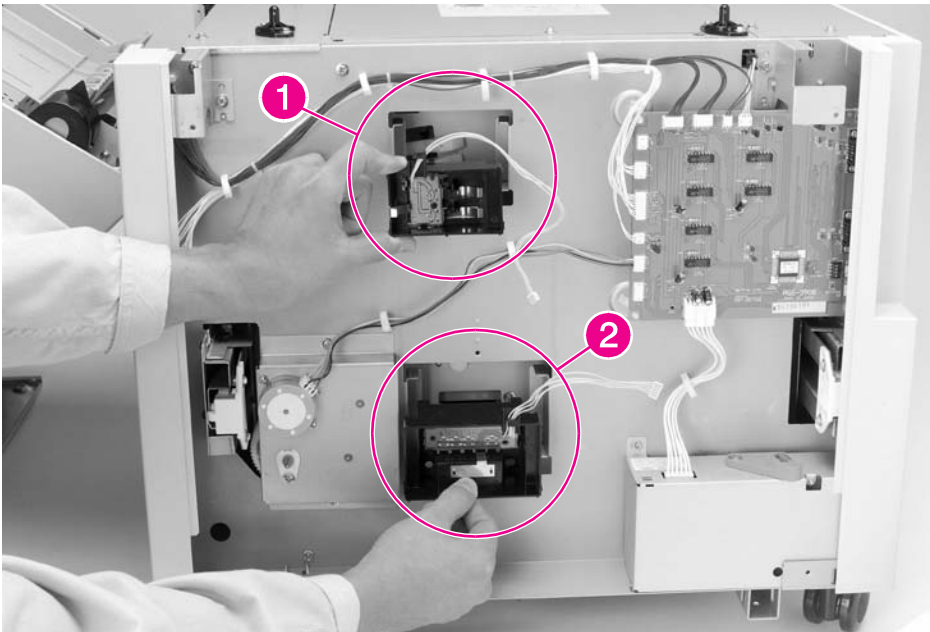

Figure 6-77 2000-sheet Input Tray Paper Size and Paper Quantity Switch Assemblies (2 of 2)

Vertical Transfer Unit (VTU)

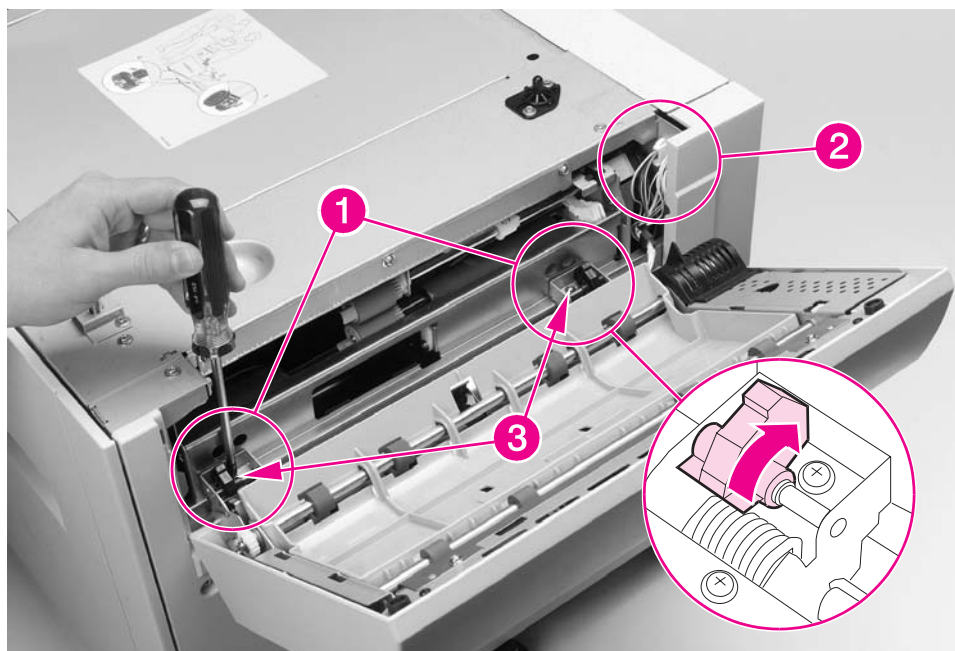

Figure 6-78 2000-sheet Input Tray Vertical Transfer Unit (VTU)

- 1 Open the Vertical Transfer Unit (VTU) on the 2000-sheet Input Tray.
- 2 Rotate the 2 plastic cams on the VTU hinges toward the 2000-sheet Input Tray to the secure position (Figure 6-78, callout 1).

WARNING!

Do **not** release the plastic cams from the secure position while the VTU is off. The springs on the cams are very strong and may cause injury.

- 3 Locate the 2 cables that run from the VTU to the chassis at the right side's upper-back corner (Figure 6-78, callout 2) and disconnect the 2 cables from the chassis.
- 4 Remove the 2 screws that secure the VTU to the chassis: 1 screw near each end of the VTU (Figure 6-78, callout 3).
- 5 Lift the VTU straight up to clear the metal locating tabs on the chassis.

Note

Reassembly notes are on the next page.

To Reinstall:

WARNING!

Release the plastic cams only **after** tightening the screws that secure the VTU to the chassis.

- 1 Before tightening the screws, make sure that the metal locating tabs are in place.
- 2 Reconnect the cables that run from the VTU to the chassis at the right side's upper-back corner (callout 2).

Tension Springs

- 1 Remove the Left Cover of the 2000-sheet Input Tray (see figure 6-66 on page 289).

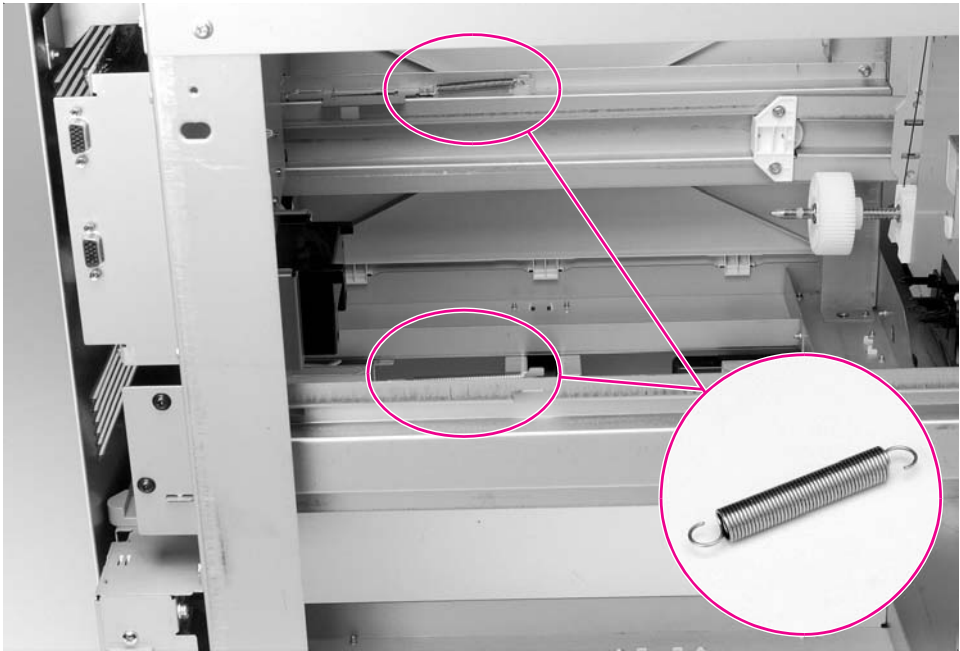

Figure 6-79 2000-sheet Input Tray Tension Springs

- 2 Open the paper tray on the 2000-sheet Input Tray all the way to the stops.
- 3 Inside the tray cavity, locate and remove the 2 springs on the tray runners: 1 spring on left runner (left side of the chassis) and 1 spring on the right runner (right side of the chassis) as shown in Figure 6-79.

Locating Pins

- 1 Remove the printer from the 2000-sheet Input Tray.

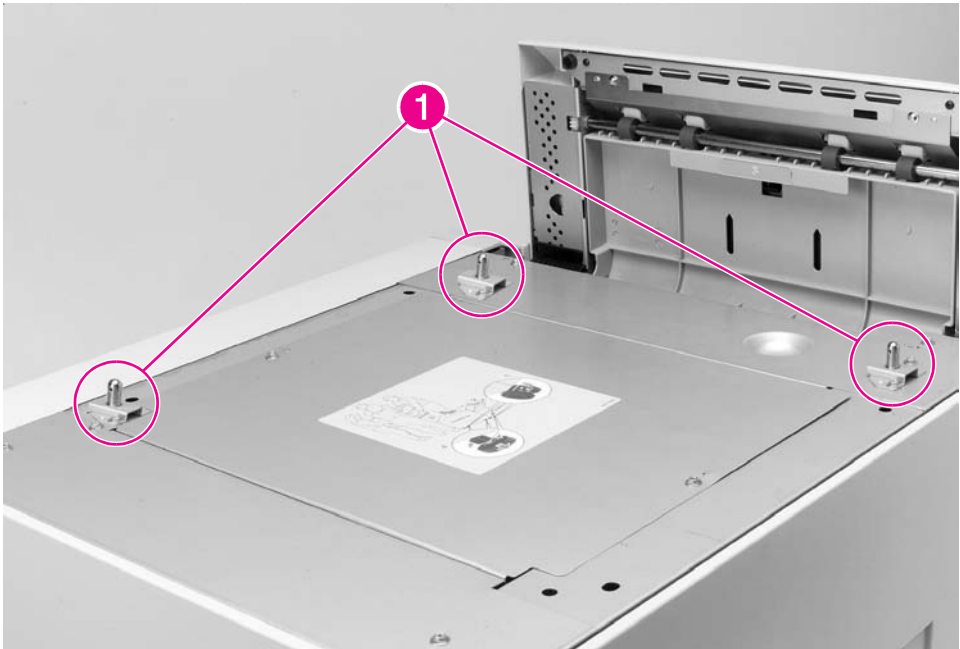

Figure 6-80 2000-sheet Input Tray Locating Pins

- 2 Locate the 3 Locating Pins on the top of the 2000-sheet Input Tray (Figure 6-80, callout 1), and remove the 2 screws on each Locating Pin.
- 3 To remove the Locating Pins lift them straight up.

Casters and Stabilizing Feet

- 1 Remove the printer from the 2000-sheet Input Tray.

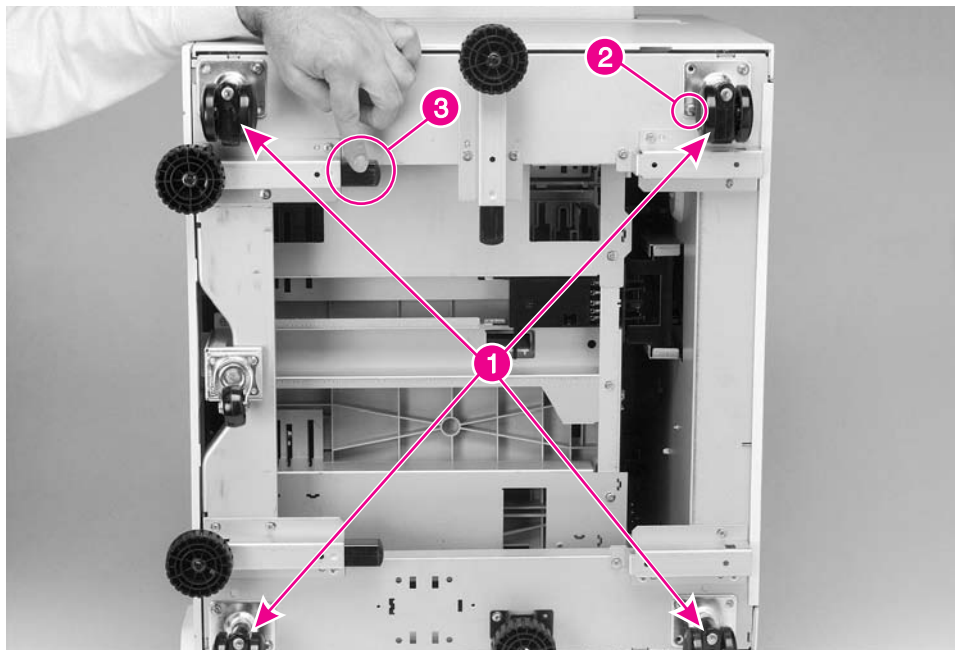

Figure 6-81 2000-sheet Input Tray Casters

- 2 Tip the 2000-sheet Input Tray onto its left side.
- 3 Locate the 4 Casters, 1 on each corner of the chassis (Figure 6-81, callout 1).
- 4 Remove a Caster by removing the 2 screws that hold the Caster to the chassis (callout 2).

Note

To remove the stabilizing feet press as shown in callout 3, and release the stabilizing feet.

To Reinstall:

- 1 Tighten the screws securely when reinstalling each caster (callout 2).

Adjustable Foot

- 1 Remove the printer from the 2000-sheet Input Tray.

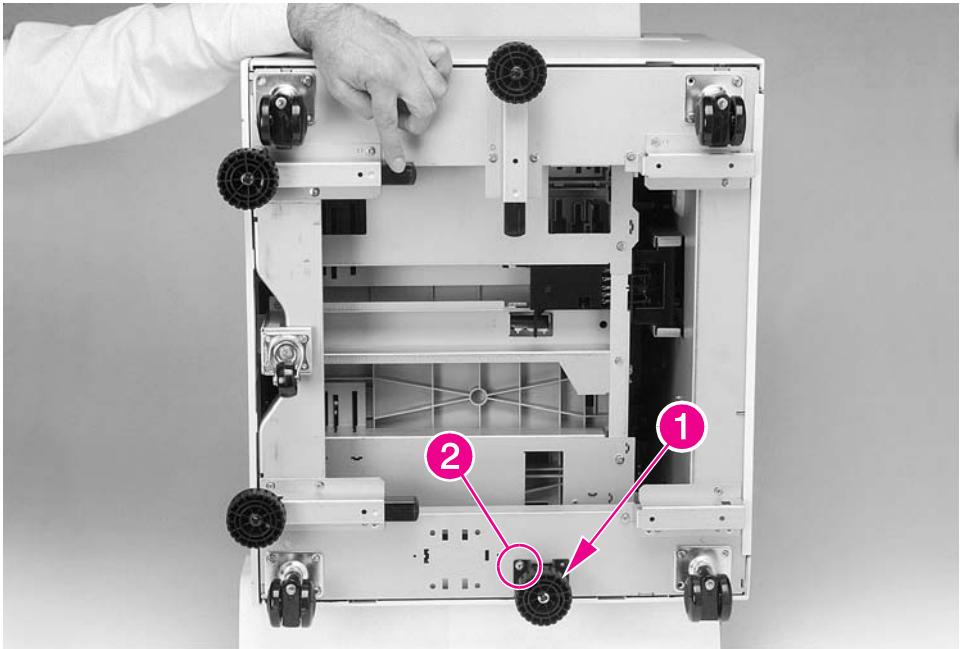

Figure 6-82 2000-sheet Input Tray Adjustable Foot

- 2 Tip the 2000-sheet Input Tray onto its left side.
- 3 Locate the Adjustable Foot (Figure 6-82, callout 1), and remove the 2 screws that secure the Adjustable Foot to the chassis (callout 2).

2 x 500-sheet Input Tray Removal and Replacement

Note

Reinstallation is generally the reverse of the removal process. Carefully follow any additional instructions provided under “To Reinstall.”

Orientation of the 2 x 500-sheet Input Tray	315
Back Cover	316
Left Cover	317
Vertical Transfer Unit (VTU)	318
Right Cover	321
Front Top Cover	324
Trays 4 and 5	327
Pickup Assembly	329
Paper Deck Drive Assembly	331
Pickup, Feed, and Separation Rollers	333
Controller PCA	334
Tray-Size Sensing PCA	335
Power Supply	337
Main Cable	338
Storage Paper Tray	340
Front Door (Storage Area)	341
Casters	342
Foot Tip and Adjustable Foot Tip (Stabilizing Feet)	343
Locating Pins	344
Front LED PCA	345

Orientation of the 2 x 500-sheet Input Tray

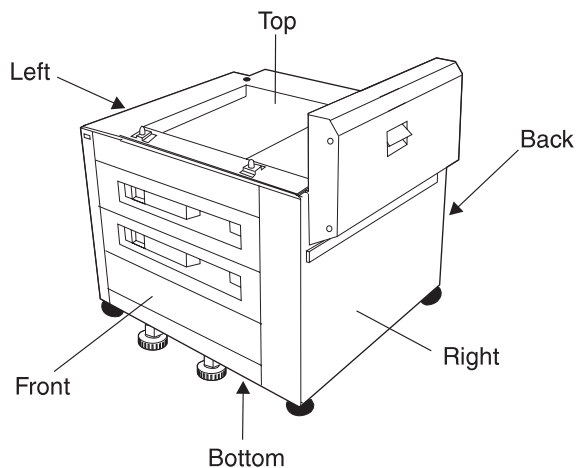

Figure 6-83 Orientation of the 2 x 500-sheet Input Tray

To remove the 2 x 500-sheet Input Tray from the printer, see page 207.

Back Cover

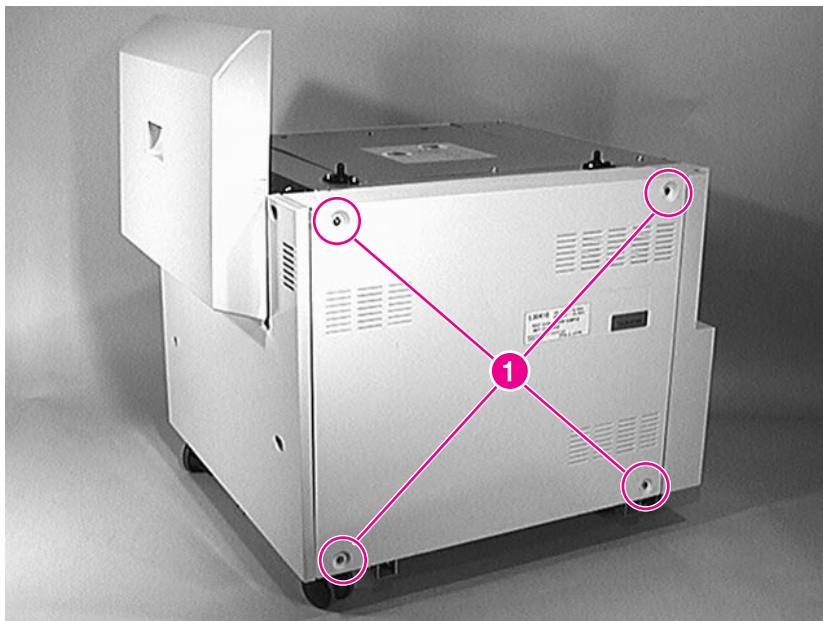

Figure 6-84 Back Cover

- 1 Remove 4 screws (callout 1).
- 2 Release and pull out the Back Cover.

Note

The reassembly procedure is the reverse of the disassembly procedure.

Left Cover

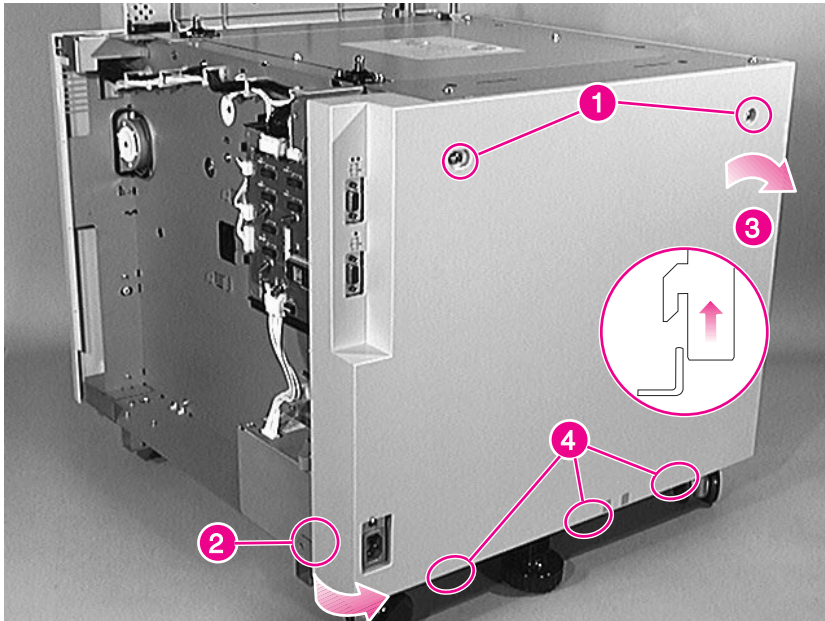

Figure 6-85 Left Cover

- 1 Unplug the power cord and C-link interface cables, and remove the Back Cover (page 316).
- 2 Remove 2 screws (callout 1).
- 3 Release the tab next to the power supply (callout 2).
- 4 Tip the cover outward to release the screw holders (callout 3).
- 5 Lift the cover up to clear the bottom tabs (callout 4).

Note

Align the screw holes with their holders when you replace the cover.

Vertical Transfer Unit (VTU)

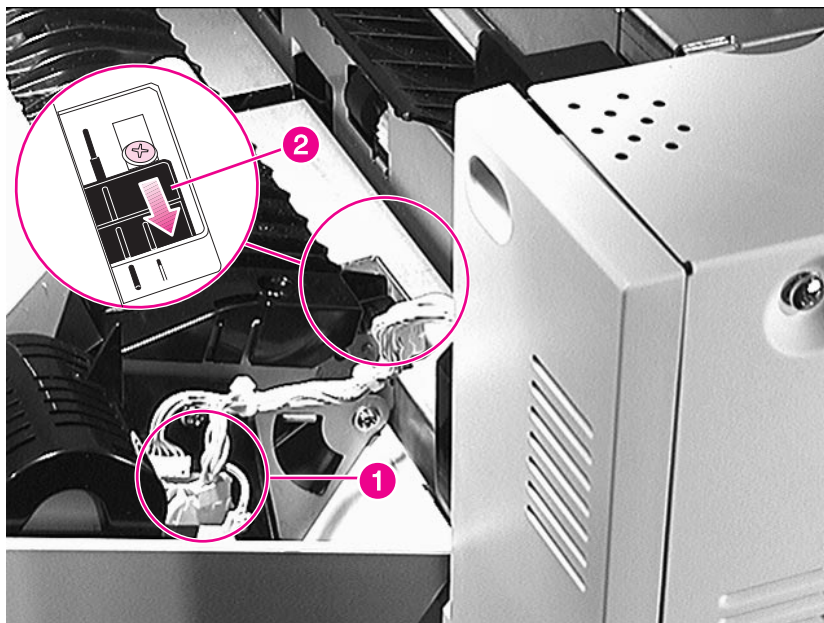

Figure 6-86 Vertical Transfer Unit (VTU) (1 of 3)

- 1 Open the Vertical Transfer Unit (VTU) on the 2 x 500-sheet Input Tray.
- 2 Unplug the 3 cables that connect the VTU to the chassis (callout 1).

WARNING!

Do **not** release the plastic cams from the secure position while the VTU is off. The springs on the cams are very strong and may cause injury.

- 3 Slide the 2 plastic cams on the VTU hinges to the secure position (callout 2).

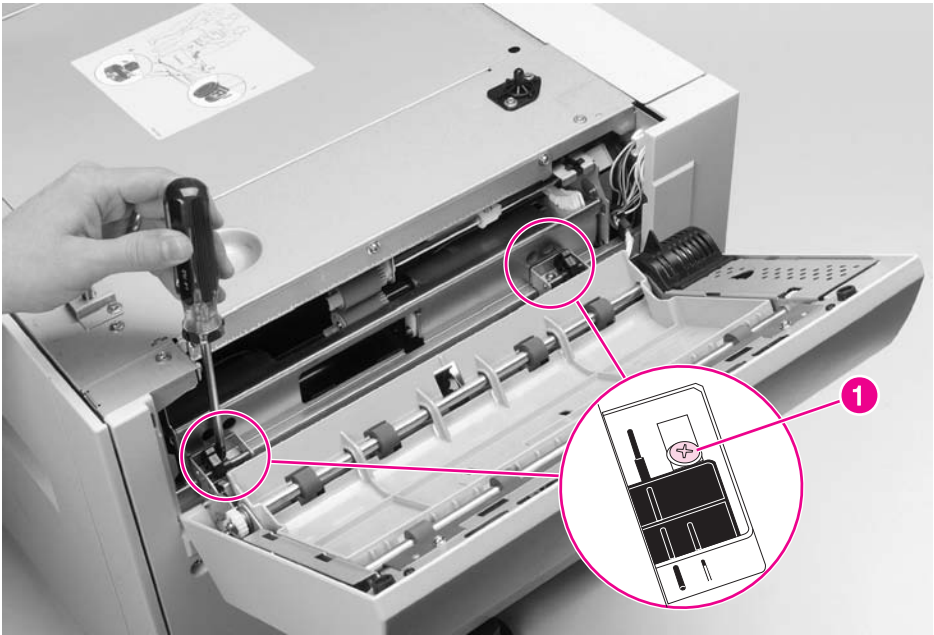

Figure 6-87 Vertical Transfer Unit (VTU) (2 of 3)

- 4 Remove the 2 screws that secure the VTU to the chassis: 1 screw near each end of the VTU (callout 1).
- 5 Lift the VTU straight up to clear the metal tabs on the chassis.

To reinstall:

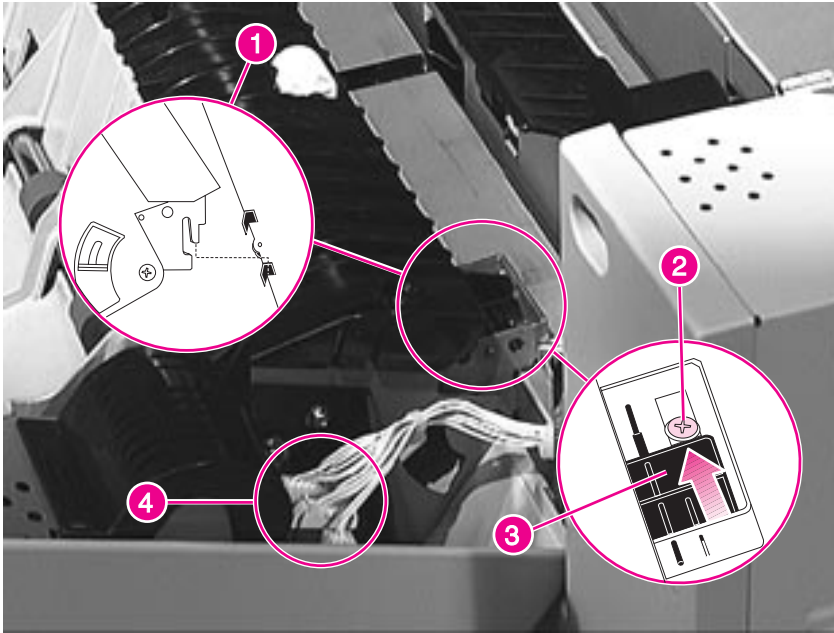

Figure 6-88 Vertical Transfer Unit (VTU) (3 of 3)

WARNING!

To avoid injury, tighten the screws that secure the VTU to the chassis **before** you release the plastic cams.

- 1 Insert the metal tabs into the slots of the chassis (callout 1).
- 2 Tighten the screws (callout 2).
- 3 Release the cams (callout 3).
- 4 Plug in the 3 cables that connect the VTU to the chassis (callout 4).

Right Cover

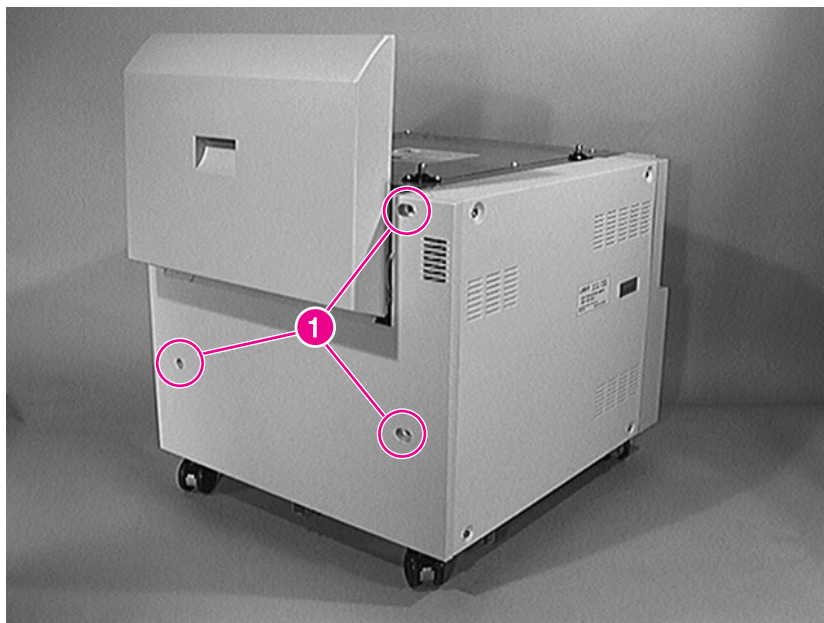

Figure 6-89 Right Cover (1 of 3)

- 1 Remove the Back Cover (page 316) and the Vertical Transfer Unit (VTU) (page 318).
- 2 Remove 3 screws (callout 1).

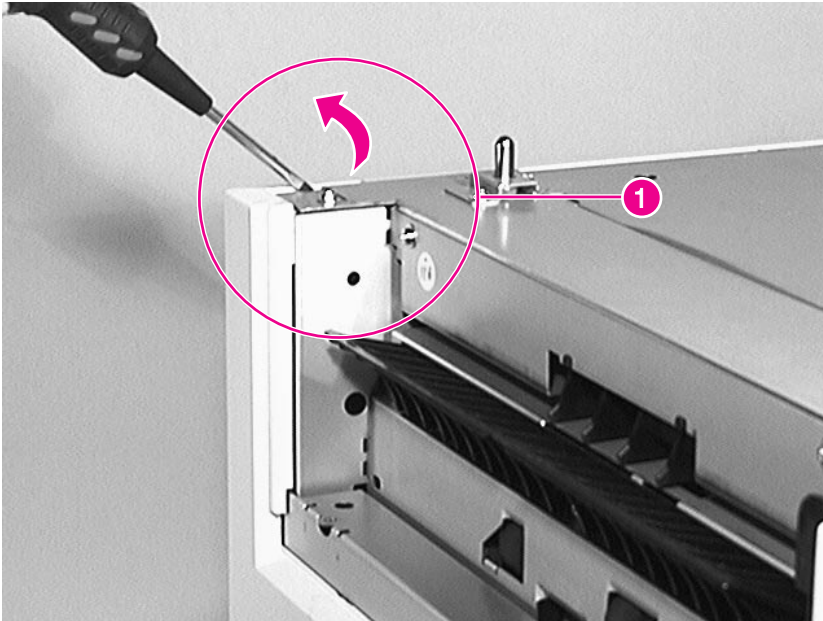

Figure 6-90 Right Cover (2 of 3)

- 3 Release the left side of the Right Cover from the tabs, and remove it (callout 1).

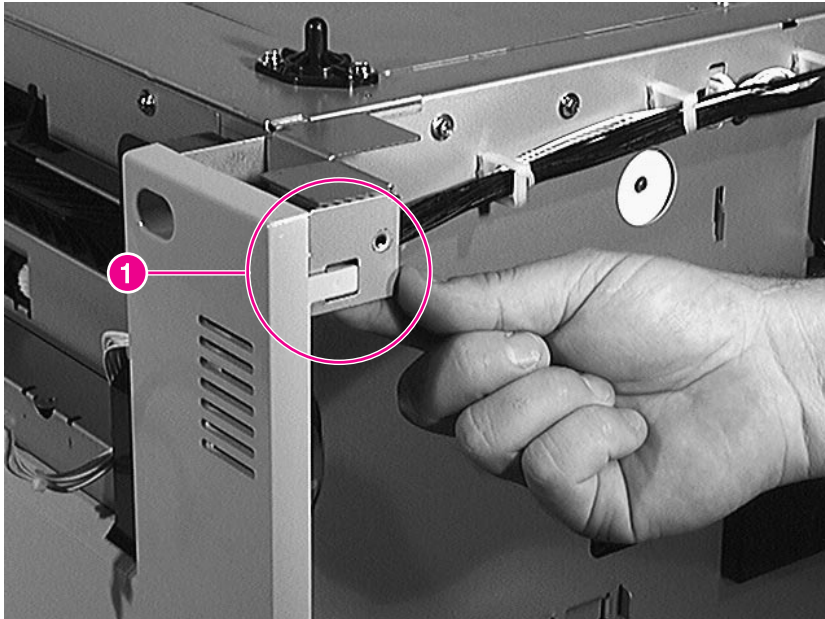

Figure 6-91 Right Cover (3 of 3)

- 4 Release the tab from the right side of the Right Cover as shown in figure 6-91 (callout 1).
- 5 Lift the Right Cover up to clear the tabs at the bottom.

Front Top Cover

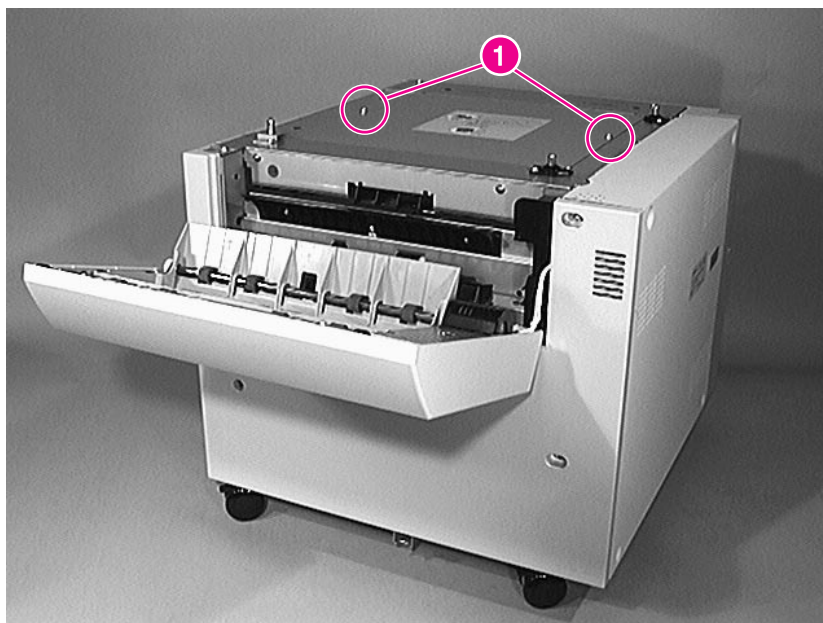

Figure 6-92 Front Top Cover (1 of 3)

- 1 Remove the printer from the 2 x 500-sheet Input Tray.
- 2 Remove 2 screws (callout 1).
- 3 Remove Top Cover. The Top Cover has a label.

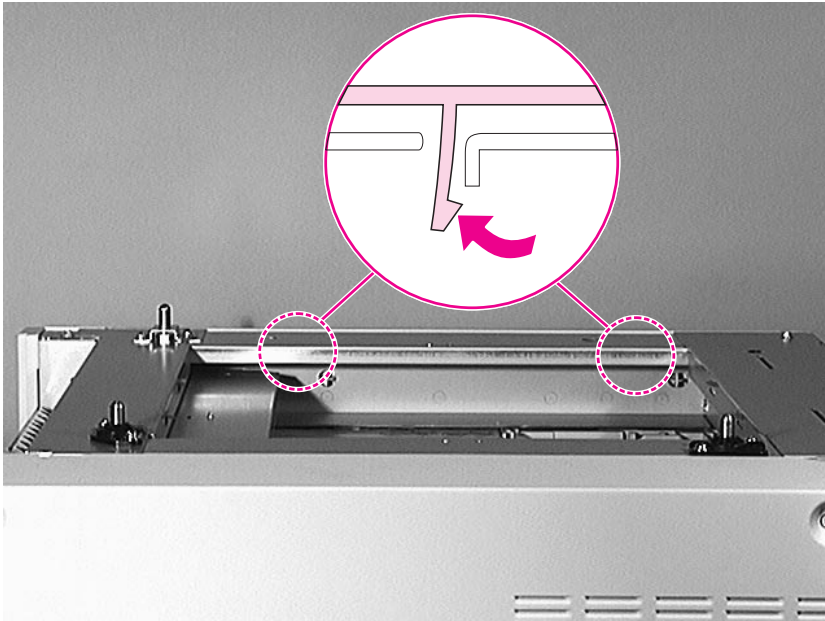

Figure 6-93 Front Top Cover (2 of 3)

- 4 From inside of the unit release the central tabs, as shown in figure 6-93.



Figure 6-94 Front Top Cover (3 of 3)

- 5 Push the front top cover to the left to release the remaining tabs.

Note

Align the pins when you replace the Top Front Cover.

Trays 4 and 5

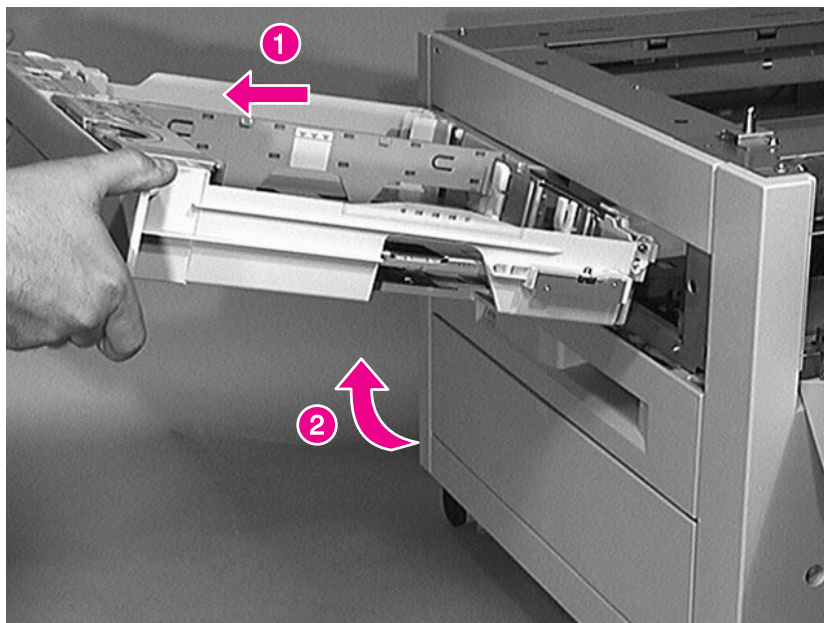

Figure 6-95 Trays 4 and 5 (1 of 2)

- 1 Open the tray and pull it out to the stop (callout 1).
- 2 As you pull out the tray, tip up the end as shown in callout 2 to release the stop mechanism at the right rear of the tray.

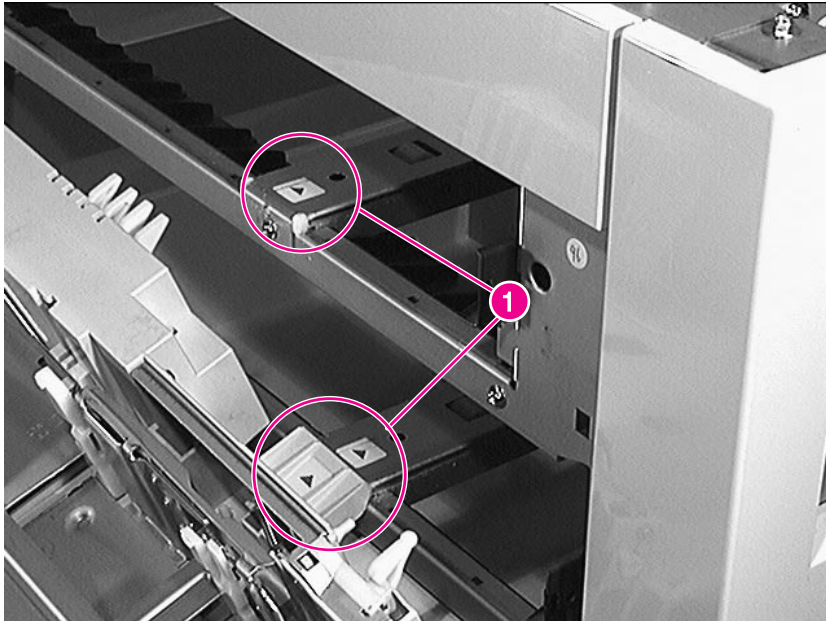

Figure 6-96 Trays 4 and 5 (2 of 2)

To Reinstall:

- 1 Tip the end of the tray downward. Align the guides with the left rear corner of the tray and the arrow at the lower rear center of the tray (callout 1).
- 2 Insert the tray no more than 2 inches (5 centimeters) into the chassis.
- 3 Tip the end of the tray up to engage the tray stop mechanism (located at the right rear of the tray opening).
- 4 Slide the tray until it latches into place.

Pickup Assembly

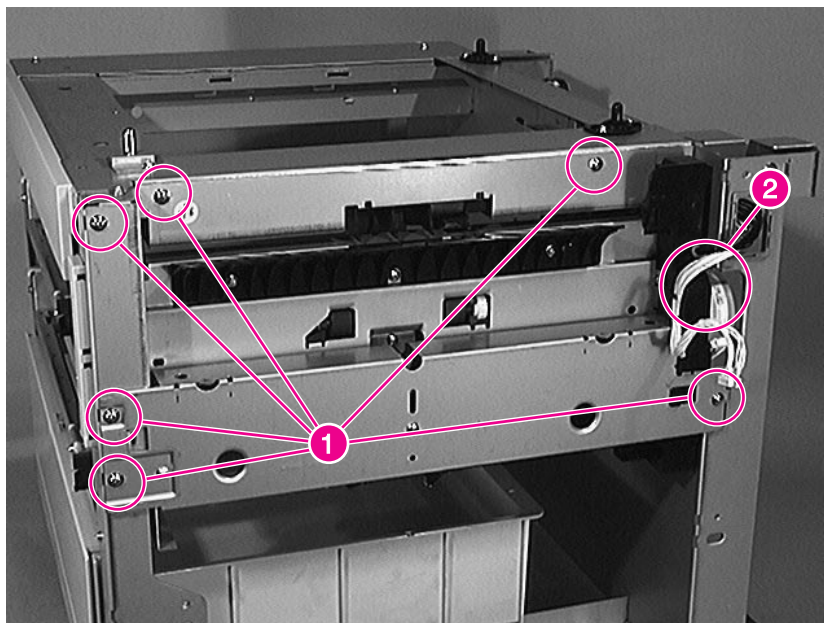

Figure 6-97 Pickup Assembly (1 of 2)

- 1 Remove trays 4 and 5 (page 327), the Right Cover (page 321), and the Vertical Transfer Unit (VTU) page 318.
- 2 Remove 6 screws (callout 1).
- 3 Remove the cable from the bracket (callout 2).

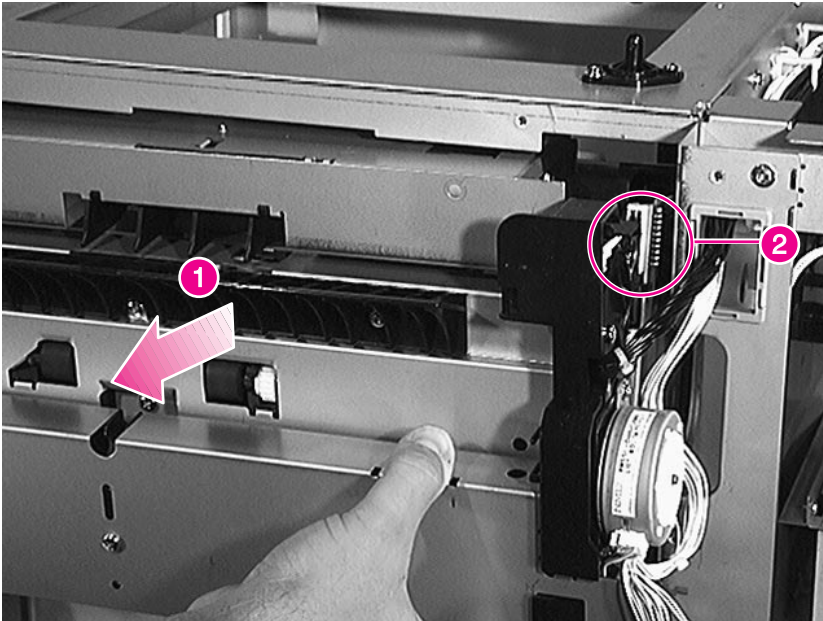

Figure 6-98 Pickup Assembly (2 of 2)

- 4 Carefully slide the Pickup Assembly straight out, supporting it until you can reach the connector (callout 1).
- 5 Unplug the connector (callout 2).

Paper Deck Drive Assembly

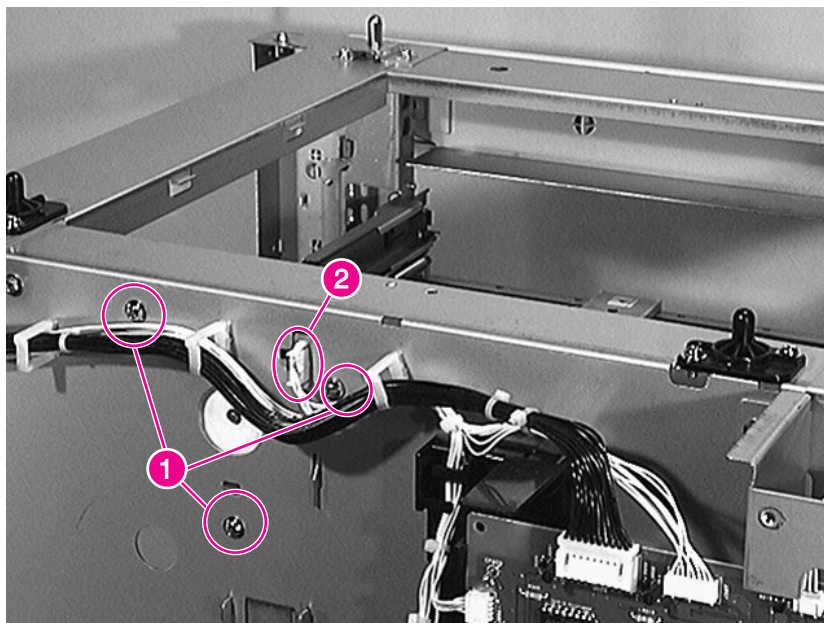

Figure 6-99 Paper Deck Drive Assembly (1 of 2)

- 1 Remove the Back Cover (page 316), Trays 4 and 5 (page 327), and the Pickup Assembly (page 329).
- 2 Remove 3 screws (callout 1).
- 3 Unplug the connector (callout 2).

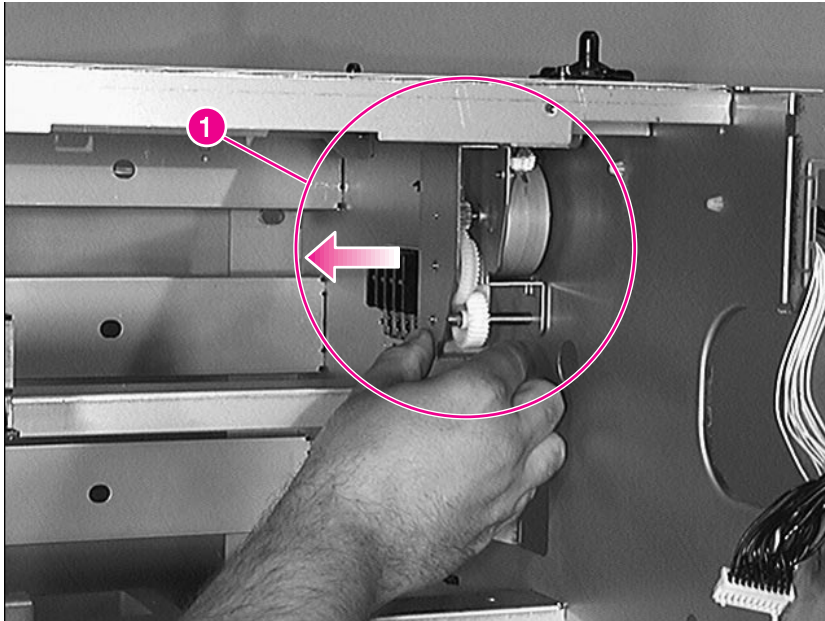

Figure 6-100 Paper Deck Drive Assembly (2 of 2)

- 4 Reach into the right side of the input device. Pull the paper deck drive assembly to the left, and then pull it straight out (callout 1).

Pickup, Feed, and Separation Rollers

There are three rollers in this assembly. The upper forward roller is the Pickup Roller, the upper rear roller is the Feed Roller, and the lower roller is the Separation Roller. The Feed and Separation Rollers are interchangeable with each other and between the trays. The Pickup Roller is interchangeable with the Pickup Rollers in Trays 2 and 3.

- Pickup Roller: figure 6-101, callout 1
- Feed Roller: figure 6-101, callout 2
- Separation Roller: figure 6-101, callout 3

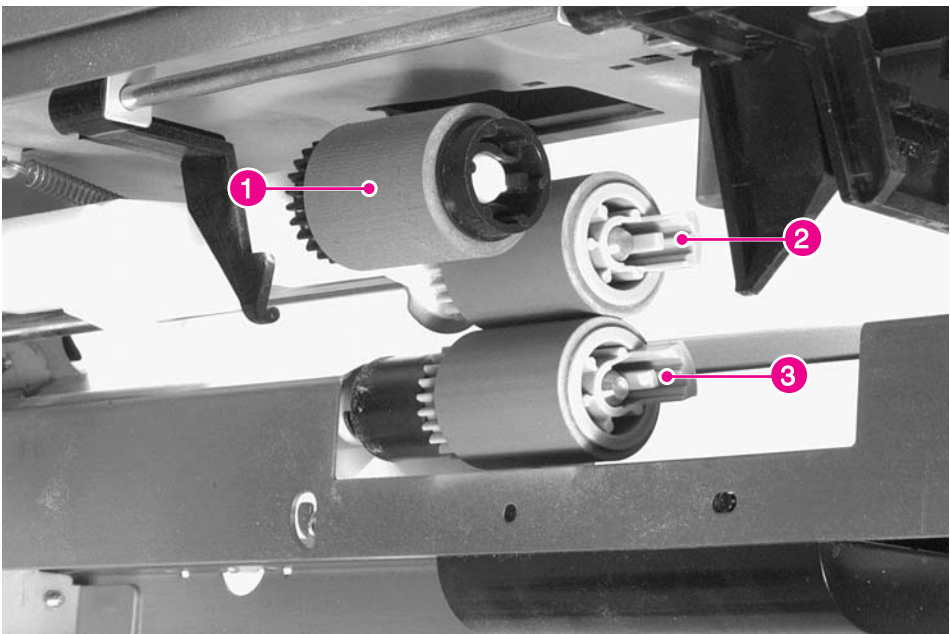

Figure 6-101 Pickup, Feed, and Separation Rollers

- 1 Remove the paper tray.

Note

The Feed and Separation Rollers have protruding retaining tabs, and the Pickup Roller has recessed retaining tabs.

- 2 From inside the tray cavity, remove the rollers by pinching the retainer tabs together and sliding the roller off the shaft.

Controller PCA

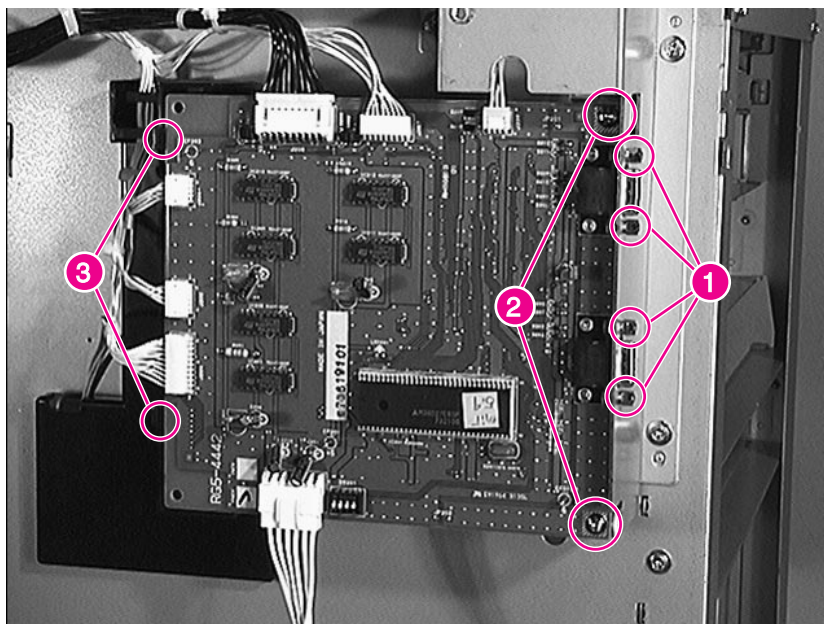

Figure 6-102 2 x 500-sheet Input Tray Controller PCA

- 1 Remove the Back Cover (page 316) and the Left Cover (page 317).
- 2 Unplug all 7 connectors.
- 3 Remove 4 hex screws from the C-link connectors (callout 1).
- 4 Remove the 2 screws that hold the PCA to the metal base (callout 2).
- 5 Release the tabs at the left side (callout 3), and remove the PCA.

Tray-Size Sensing PCA

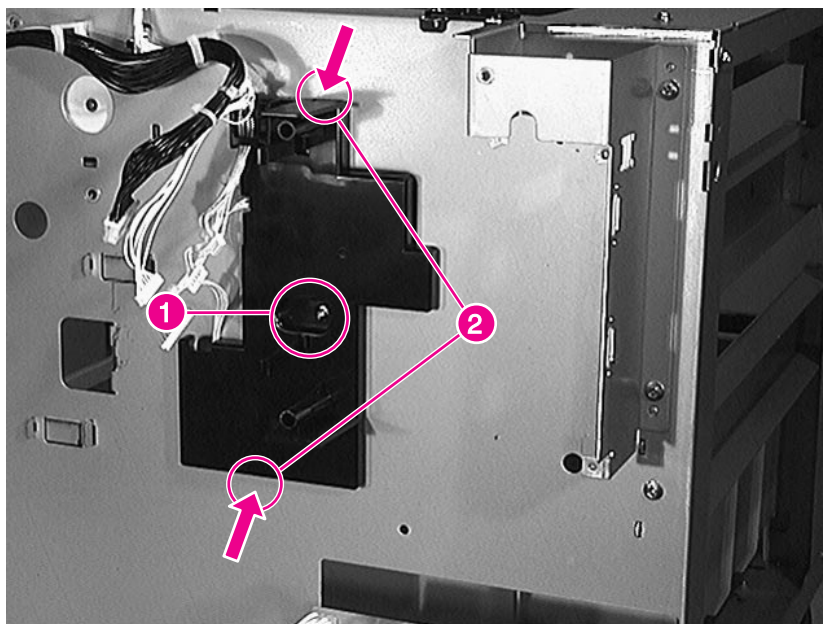

Figure 6-103 Tray-Size Sensing PCA (1 of 2)

- 1 Remove the Back Cover (page 316) and the Controller PCA (page 334).
- 2 Remove 1 screw (callout 1) from the size-sensing PCA's holder.
- 3 To remove the size-sensing PCA's holder, use a flat blade screwdriver to release the top and bottom tabs (callout 2) from the slots in the metal.

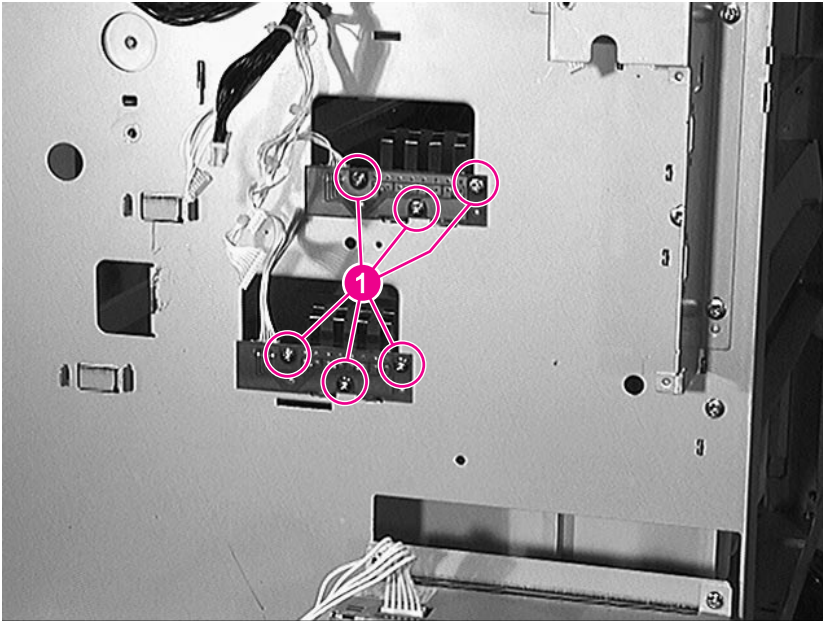

Figure 6-104 Tray-Size Sensing PCA (2 of 2)

- 4 To remove the size-sensing PCA, unplug the cable from the PCA, remove 3 screws from each PCB, and remove the PCA (callout 1).

Power Supply

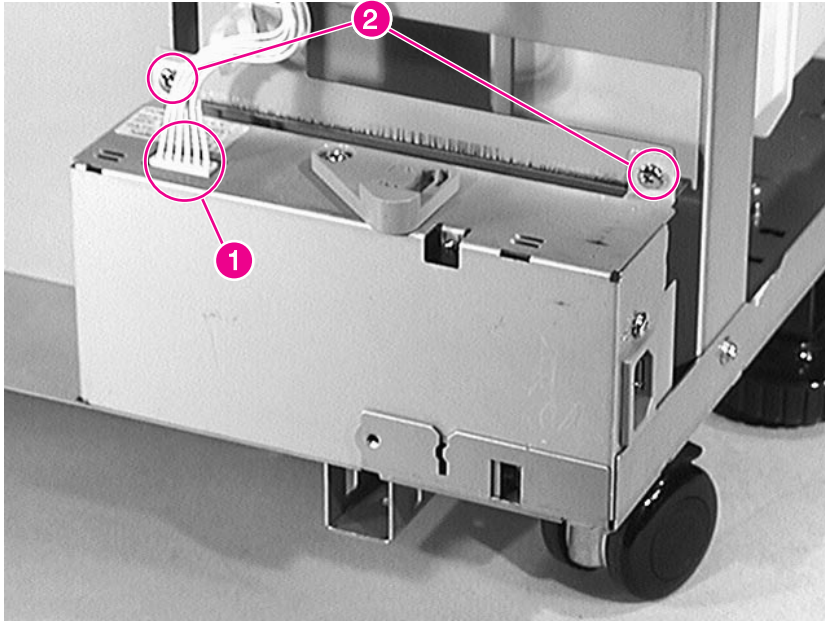

Figure 6-105 Power Supply

- 1 Remove the Back Cover (page 316) and the Left Cover (page 317).
- 2 Unplug the connector (callout 1) from the power supply. (Notice that the release tab is at the rear of the connector.)
- 3 Remove 2 screws (callout 2).
- 4 Lift the power supply off the locating pins, and slide it to the left to free it from the chassis.

To Reinstall:

- 1 Align the power supply with the locating tabs.
- 2 Plug in the power supply connector.

Main Cable

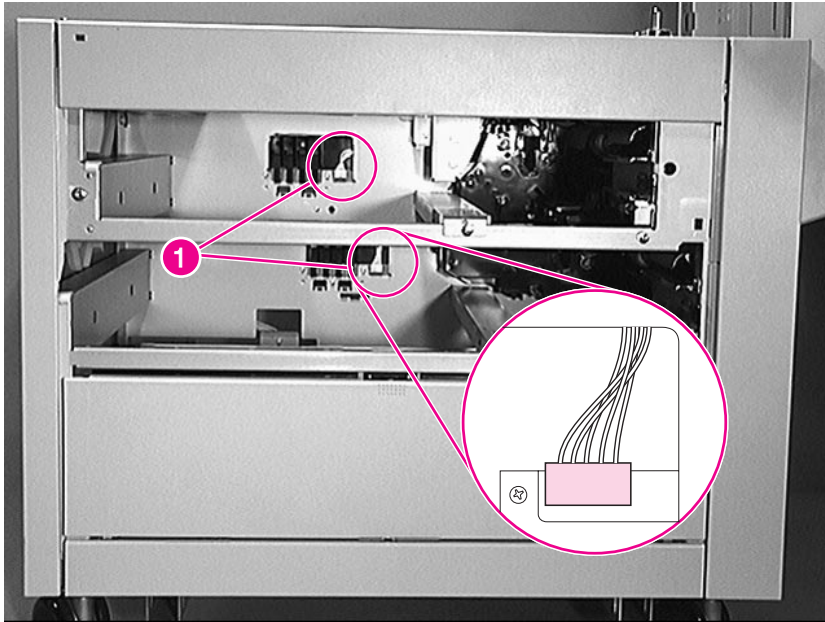

Figure 6-106 Main Cable (1 of 2)

- 1 Remove the Back Cover (page 316), the Left Cover (page 317), and Trays 4 and 5 (page 327).
- 2 Unplug both size-sensing connectors inside the 2 x 500-sheet Input Tray cavity (callout 1).

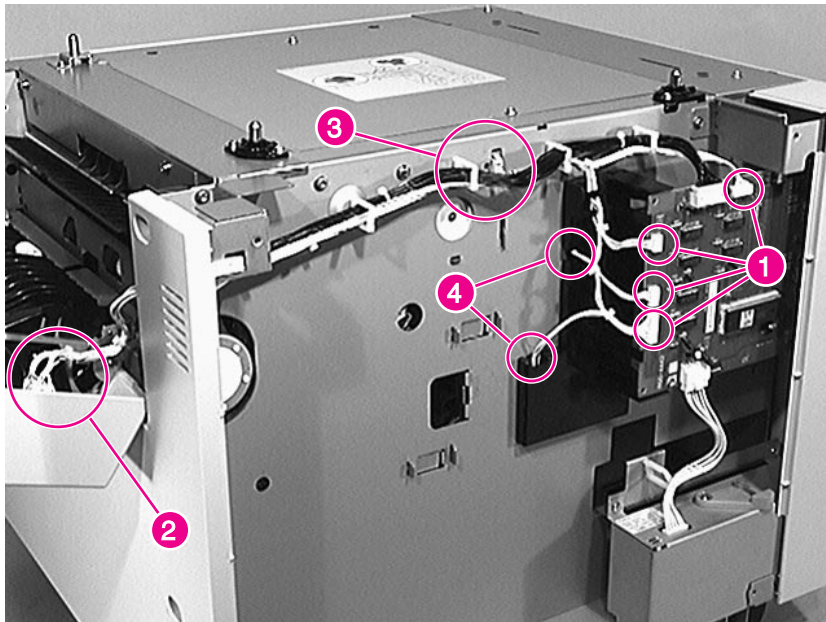

Figure 6-107 Main Cable (2 of 2)

- 3** Unplug 4 connectors from the controller PCA (callout 1), 3 from the Vertical Transfer Unit (callout 2), 1 from the Paper Deck Assembly (callout 3), and 2 from the size-sensing PCAs (callout 4).
- 4** Remove the main cable from the plastic clips.

Storage Paper Tray

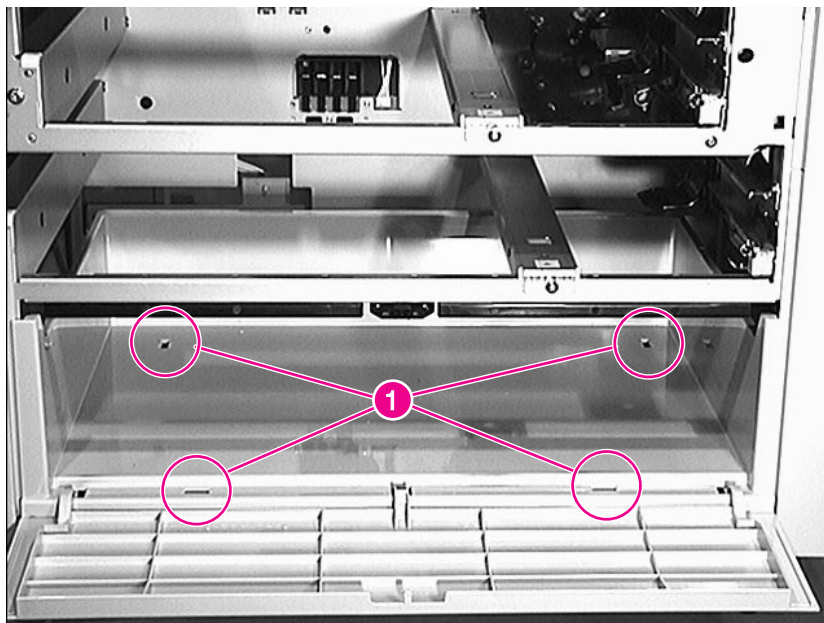

Figure 6-108 Storage Paper Tray

- 1 Remove Trays 4 and 5 (page 327).
- 2 Open the storage tray door.
- 3 Use a flat-blade screwdriver to release the tabs inside the holes indicated in figure 6-108 (callout 1).

Note

Be sure to align the door's latch when you replace the Storage Paper Tray.

Front Door (Storage Area)

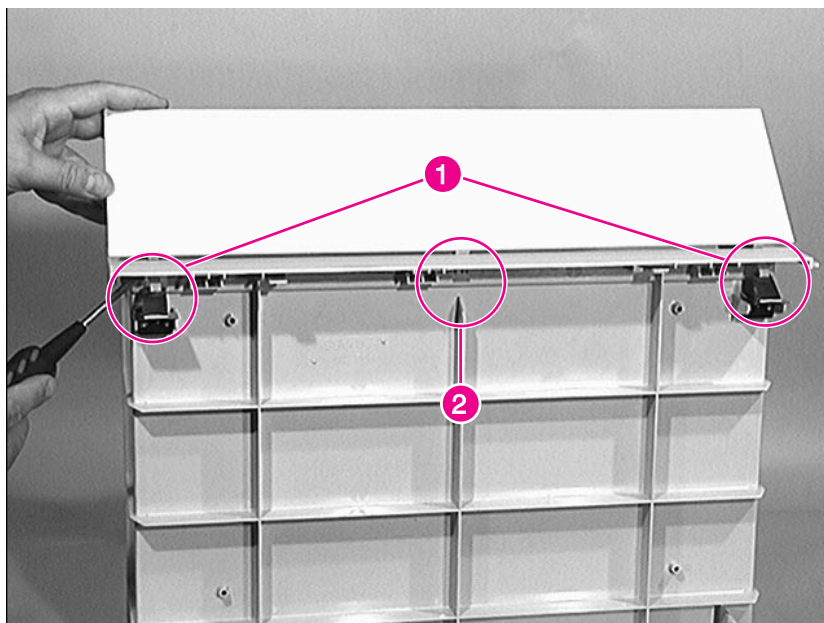

Figure 6-109 Front Door (Storage Area)

- 1 Remove the storage tray (page 340).
- 2 Release the tabs on both ends (callout 1).
- 3 Release the storage tray's door from the center tab (callout 2).

Casters

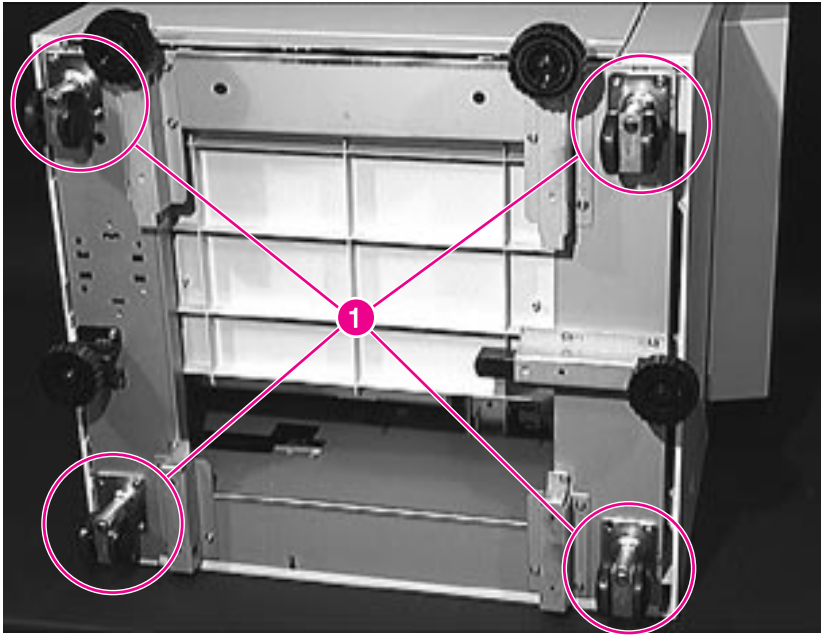

Figure 6-110 Casters

- 1 Remove the printer from the input device (page 207).
- 2 Place the 2 x 500-sheet Input Tray on its left side and locate the casters (callout 1).
- 3 Remove 2 screws from each caster and release the casters from the frame.

Note

Be sure to tighten the screws securely when you re-install the new caster.

Foot Tip and Adjustable Foot Tip (Stabilizing Feet)

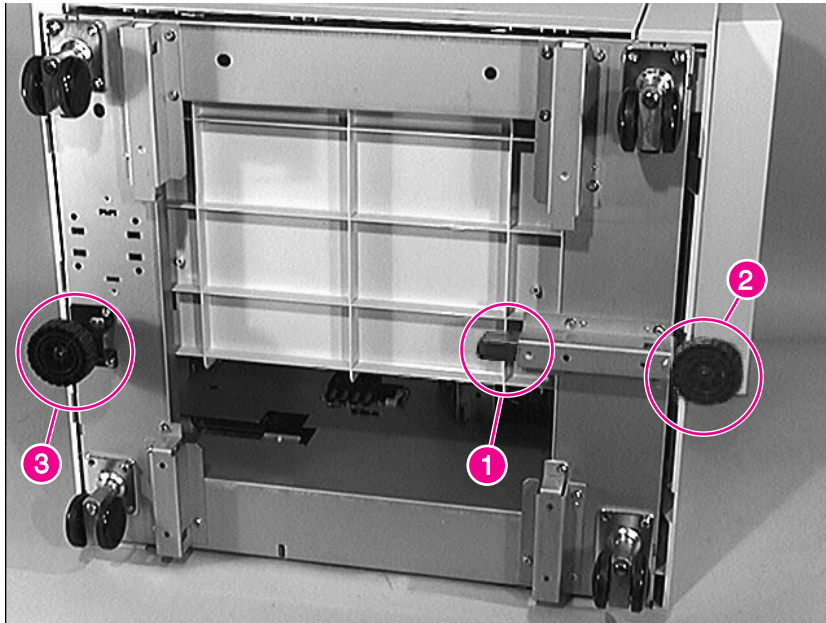

Figure 6-111 Foot Tip and Adjustable Foot Tip

- 1 Remove the printer from the input device (page 207).
- 2 Place the 2 x 500-sheet Input Tray on its left side and locate the Adjustable Foot Tip (callout 2).
- 3 Press at the location of callout 1 and slide the foot out to remove it.
- 4 Remove 2 screws that hold the stationary Foot Tip to the frame (callout 3). Remove the stationary Foot Tip.

Locating Pins

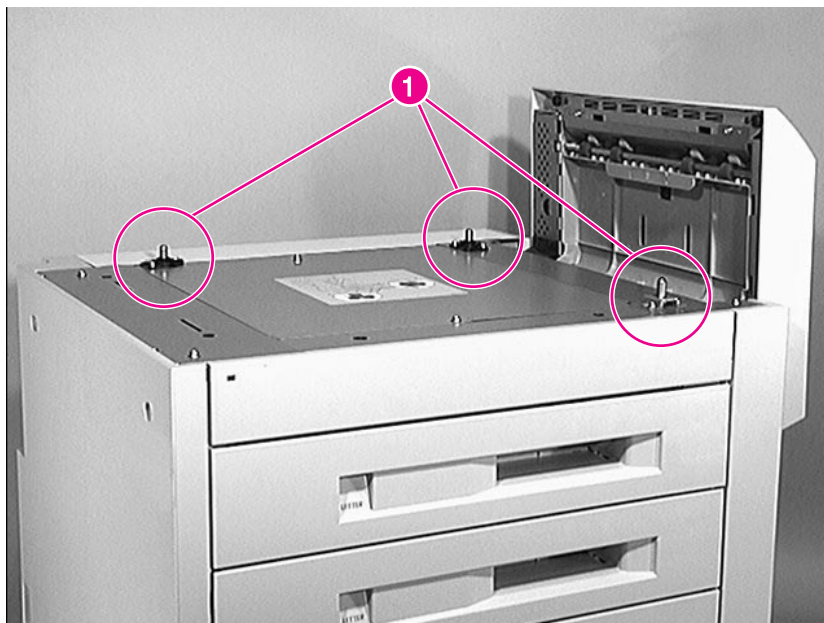

Figure 6-112 Locating Pins

- 1 Remove the printer from the input device (page 207).
- 2 Remove 2 screws each from the 3 locating pins (callout 1).

Front LED PCA

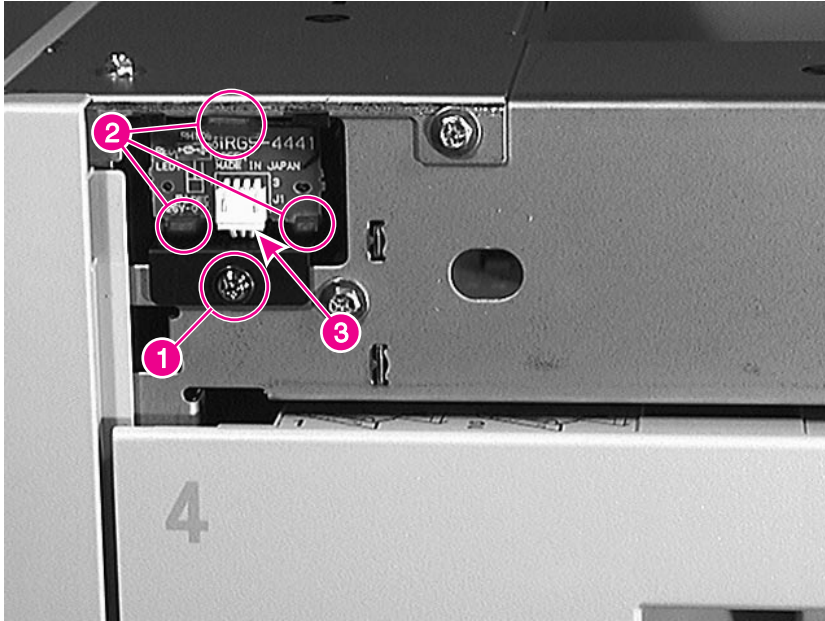

Figure 6-113 Front LED PCA

- 1 Remove the printer from the input device.
- 2 Remove the Front Top Cover. See table 6-92 on page 324.
- 3 Remove 1 screw (callout 1).
- 4 Release the tabs and remove the LED PCA (callout 2).
- 5 Unplug the cable from the PCA (callout 3).

Note Guide the cable into the correct position when you replace it.

7-bin Tabletop Mailbox Removal and Replacement

Note

Reinstallation is generally the reverse of the removal process. Carefully follow any additional instructions provided under “To Reinstall.”

Orientation of the 7-bin Tabletop Mailbox - - - - -	348
Front Cover - - - - -	349
Back Cover- - - - -	352
Top Cover - - - - -	354
Controller PCA - - - - -	358
Power Supply - - - - -	359
Right Door Assembly (Paper Path Cover) - - - - -	360
Face-down Bins - - - - -	364
Empty Bin Sensor PCA- - - - -	367
Full Bin and Interlock Sensor PCA - - - - -	369
LED PCA- - - - -	371
Face-up Sensors PCA - - - - -	372
Reversing Mechanism Motor - - - - -	373
Face-up/Diverter Assembly (Flipper) - - - - -	375
Short Tray 7 - - - - -	378
Solenoid Reversing Mechanism- - - - -	379
Flipper Solenoid - - - - -	380
Handle - - - - -	381
Latching Mechanism - - - - -	382
Cover Latch - - - - -	383

Orientation of the 7-bin Tabletop Mailbox

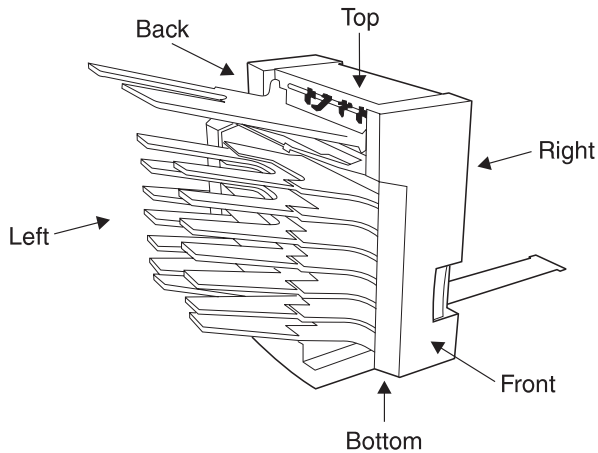

Figure 6-114 Orientation of the 7-bin Tabletop Mailbox

Note

Before you begin any removal or replacement procedure, turn off all equipment and unplug the 7-bin Tabletop Mailbox power supply cable.

To remove the 7-bin Tabletop Mailbox from the printer, see page 209.

Front Cover

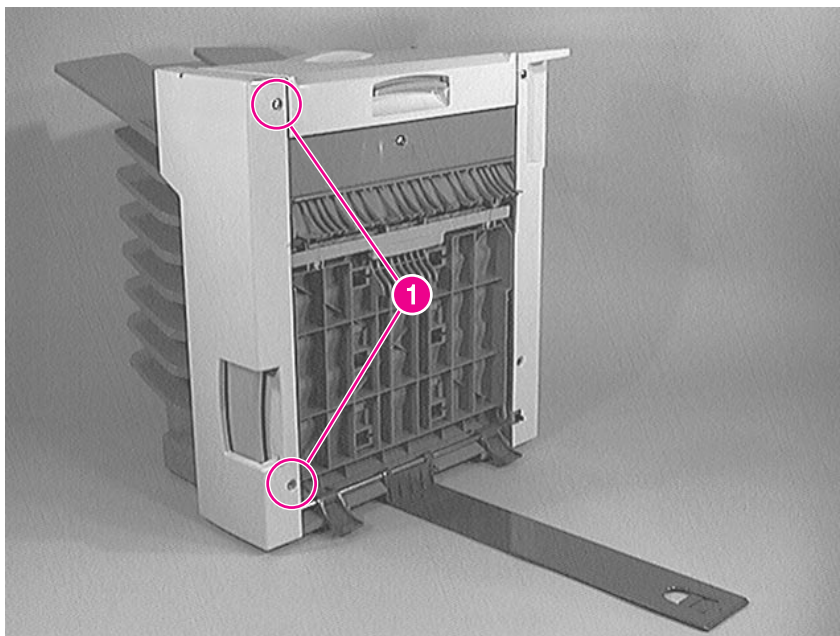

Figure 6-115 Front cover (1 of 3)

- 1 Remove 2 screws (callout 1).

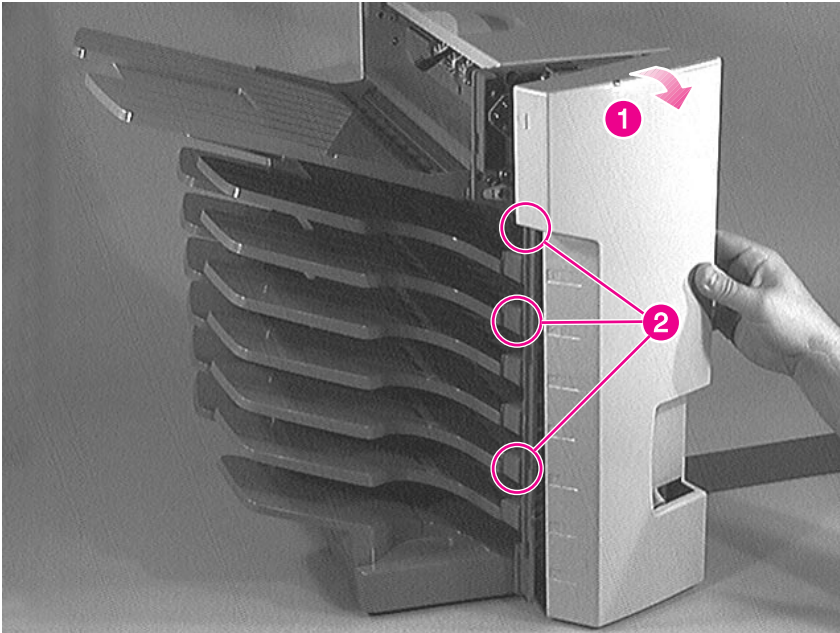

Figure 6-116 Front cover (2 of 3)

- 2** Loosen the right side of the Front Cover and pull it toward you approximately 0.5 inch (1.5 centimeters) to clear the tabs (callout 1).
- 3** Release and clear the tabs on the left side of the Front Cover (callout 2).

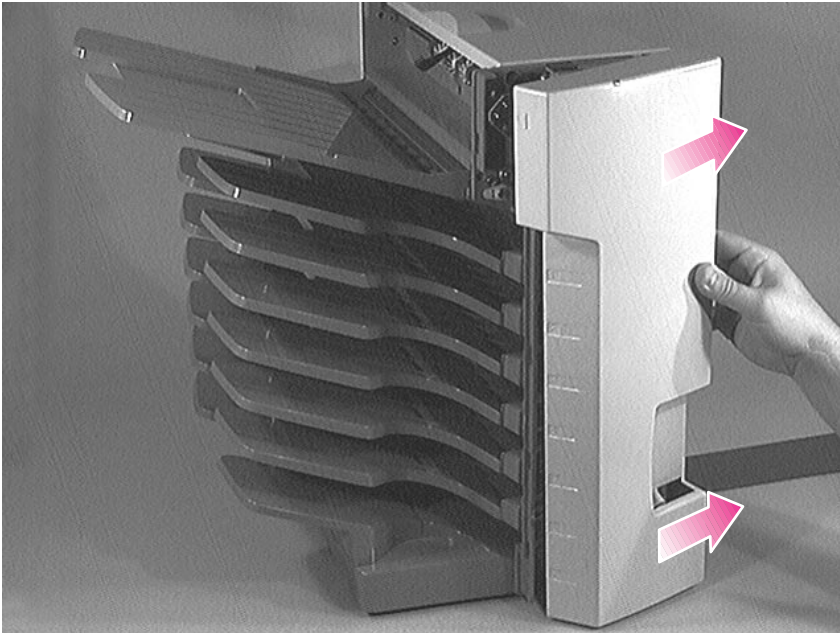

Figure 6-117 Front cover (3 of 3)

CAUTION

Be careful not to damage the handle as you remove or replace the cover. The handle can easily catch on the cover.

- 4 To clear the handle, rotate the Front Cover to the right, and remove it as shown in figure 6-117.

To replace

Note the Caution above.

Back Cover

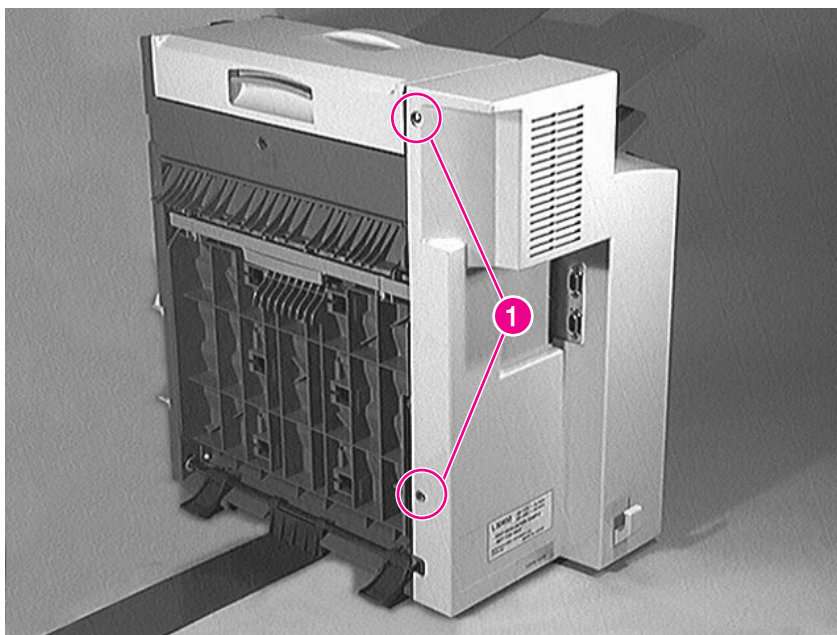

Figure 6-118 Back cover (1 of 2)

- 1 Remove 2 screws (callout 1).

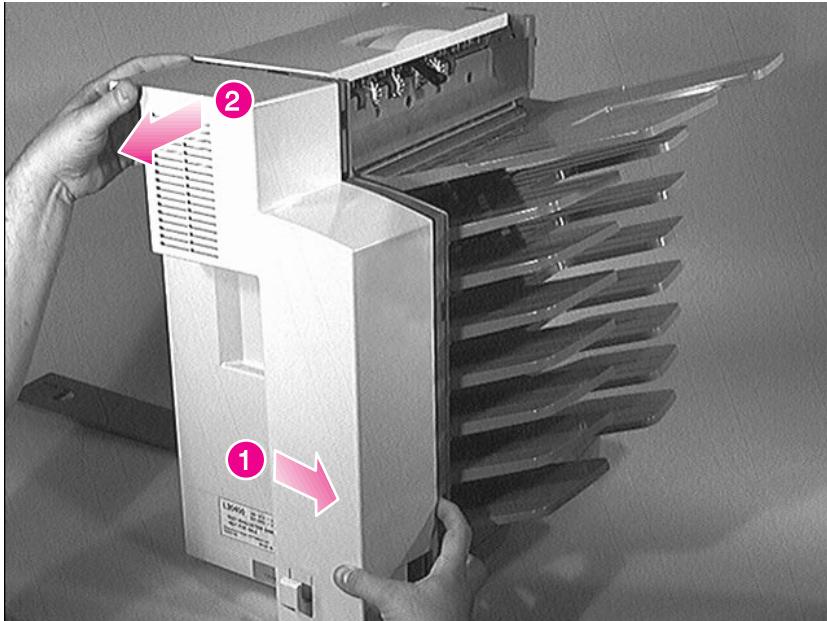

Figure 6-119 Back cover (2 of 2)

- 2 Pull the Back Cover toward you to remove it. Release corner indicated by callout 1 first.

Top Cover

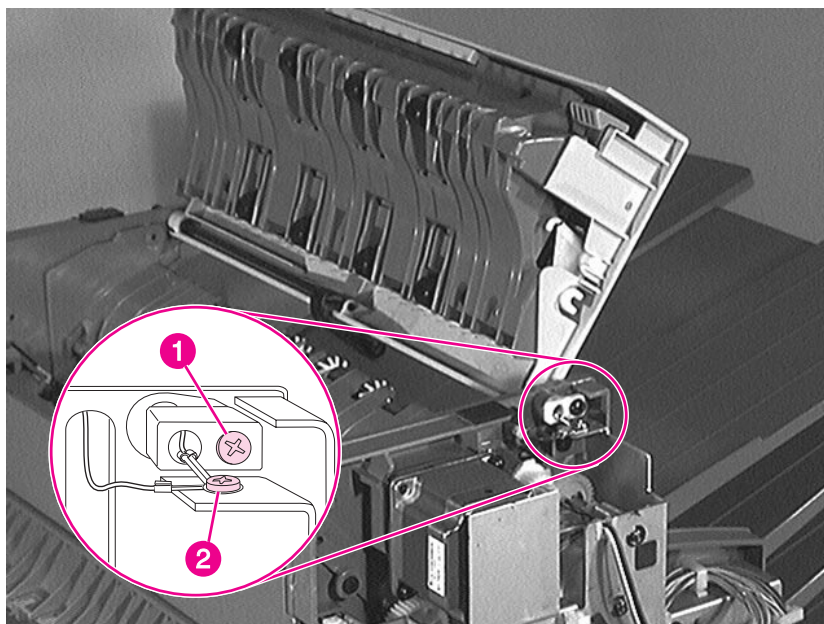

Figure 6-120 Top cover (1 of 4)

- 1 Remove the Front Cover (page 349) and the Back Cover (page 352).
- 2 Open the Top Cover, and remove the Top Cover's screw and bushing (callout 1).
- 3 Remove the grounding screw (callout 2).

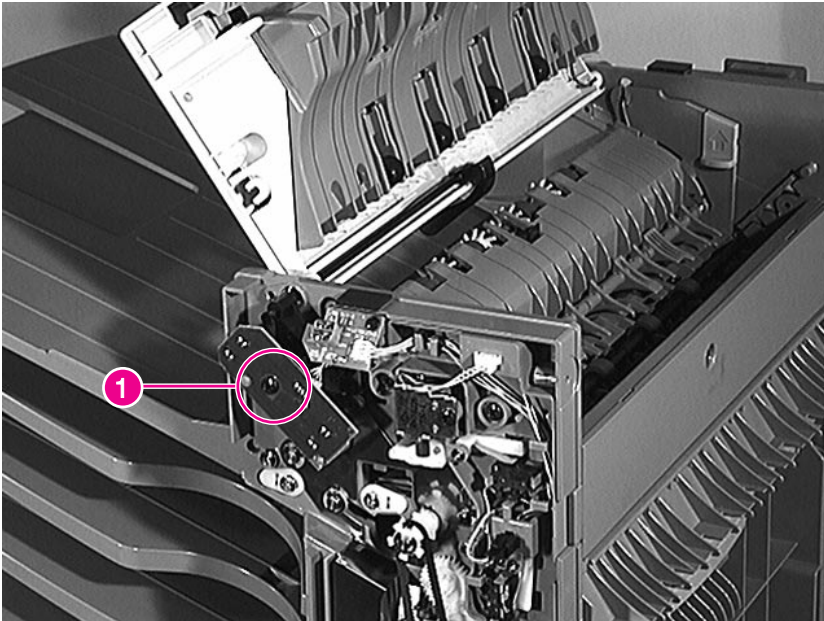

Figure 6-121 Top cover (2 of 4)

- 4 Remove the screw from the Face-up Bin-Full PCA (callout 1).

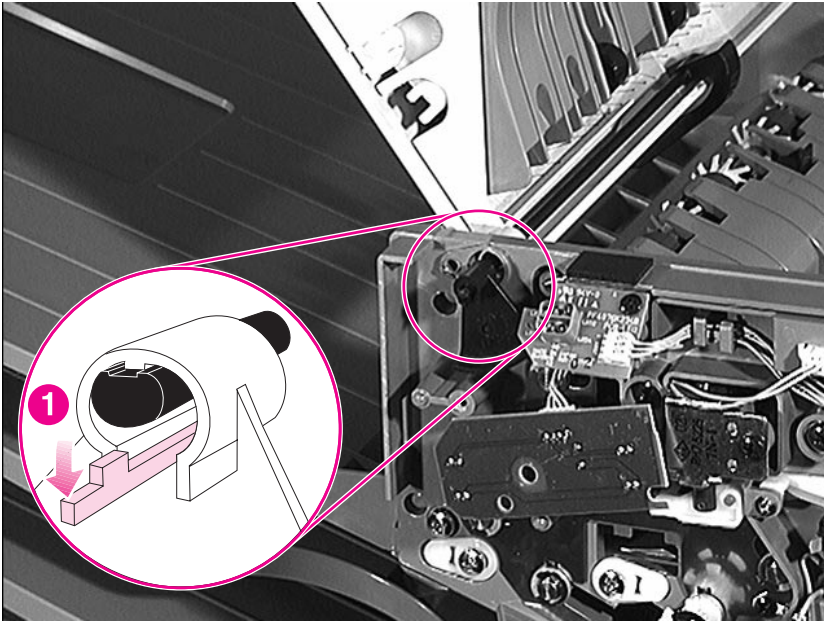

Figure 6-122 Top cover (3 of 4)

- 5 To take out the flag, push down the plastic shaft carefully, as shown in callout 1.

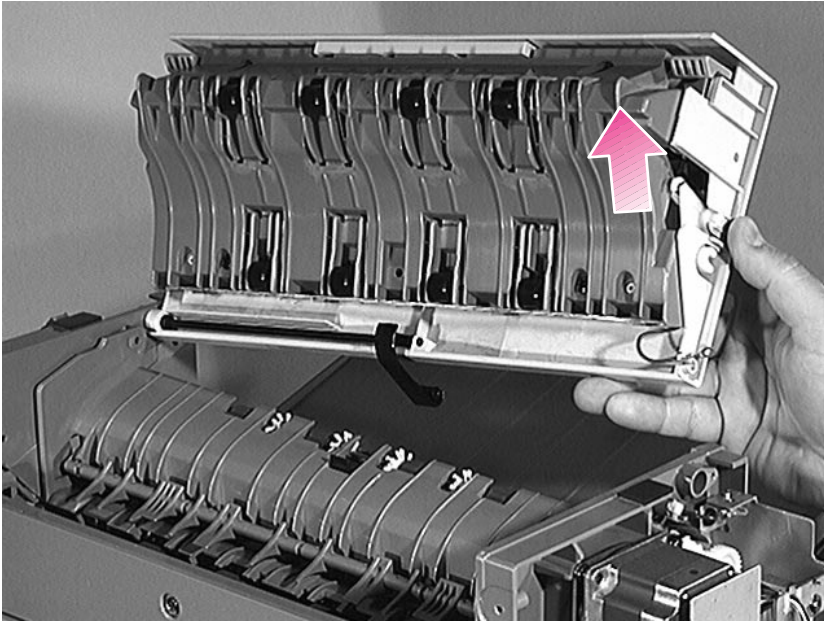

Figure 6-123 Top cover (4 of 4)

- 6 To remove the Top Cover lift the right side first as shown.

Controller PCA

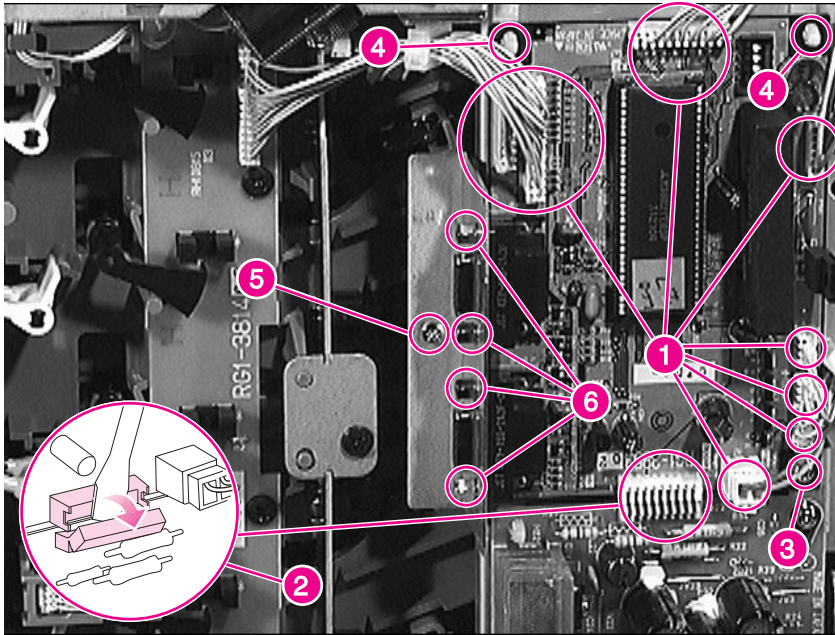

Figure 6-124 Mailbox Controller PCA

- 1 Remove the Back Cover (page 352).
- 2 Unplug 8 connectors from the Controller PCA (callout 1).
- 3 To unplug connector J202, pry it open with a flat blade screwdriver (callout 2).
- 4 Remove 1 screw from the Controller PCA below Connector J3 (callout 3).
- 5 Remove the PCA from its 2 plastic pins (callout 4).
- 6 Remove 1 screw from the plate (callout 5).
- 7 Remove 4 hex screws from the connectors on the metal plate (callout 6).
- 8 Remove the PCA controller.

Note

When you replace the Controller PCA, be sure to replace connector J202 (callout 1 in Figure 6-125).

Power Supply

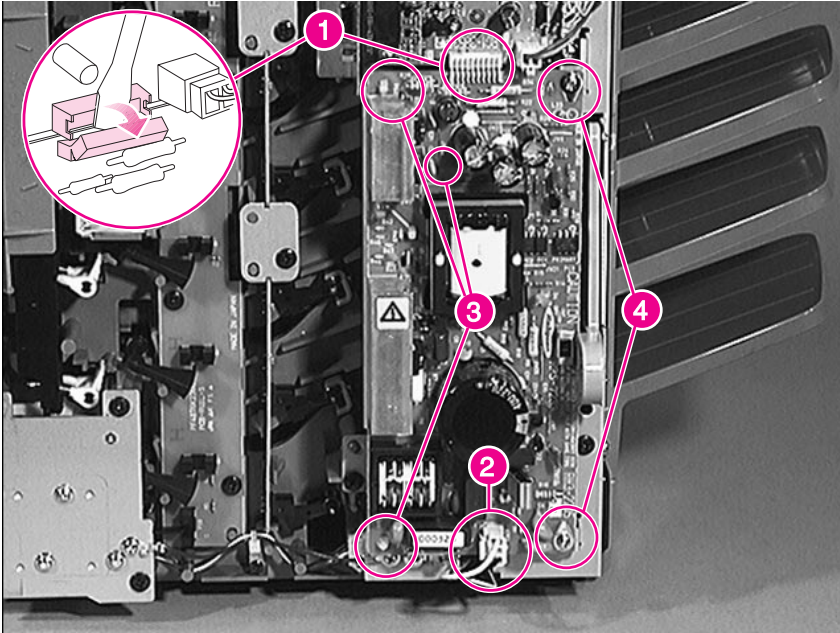

Figure 6-125 Mailbox Power Supply

- 1 Remove the Back Cover (page 352).
- 2 Release connector J202 with a flat blade screwdriver and unplug it (callout 1).
- 3 At the bottom of the power supply, unplug J201 (callout 2).
- 4 Remove 2 screws (callout 4).
- 5 Pull the power supply from its 3 plastic pins (callout 3).

Note

Be sure to replace connector J202 (callout 1) and the Power Supply Connector (callout 2).

Right Door Assembly (Paper Path Cover)

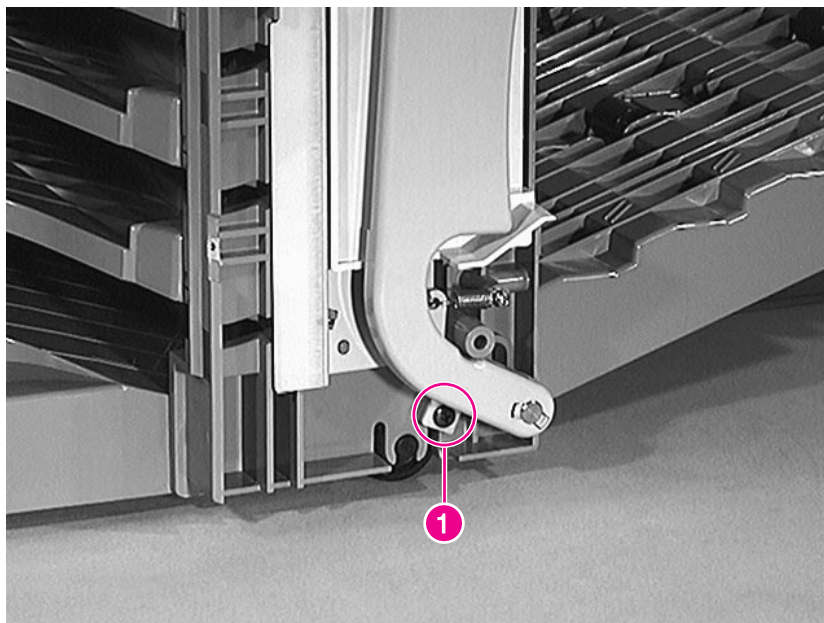

Figure 6-126 Right Door Assembly (Paper Path Cover) (1 of 5)

- 1 Remove the Front Cover (page 349) and the Back Cover (page 352).
- 2 Remove 1 screw from the front side and the bushing below the handle (callout 1).

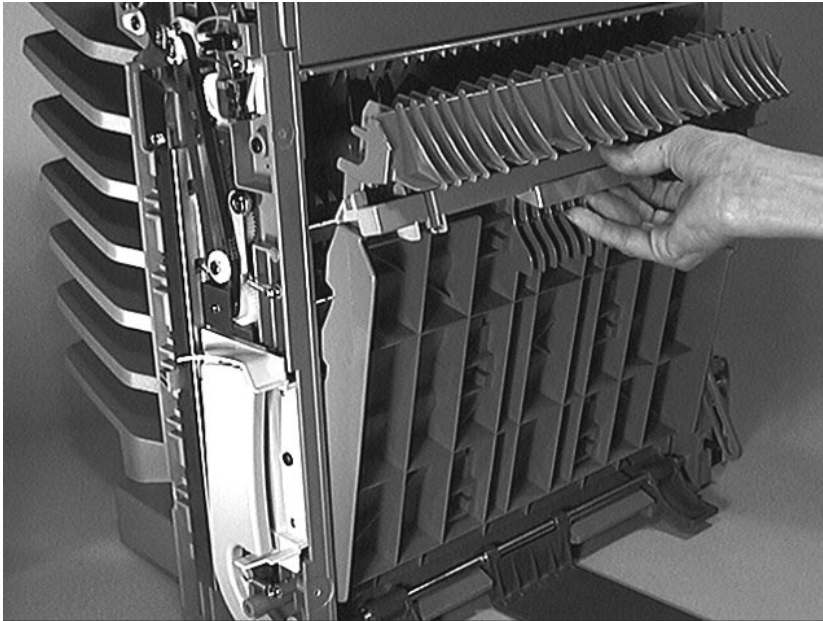

Figure 6-127 Right Door Assembly (Paper Path Cover) (2 of 5)

- 1 Grasp the green handle and pull up slightly, then out, to open the Paper Path Cover.

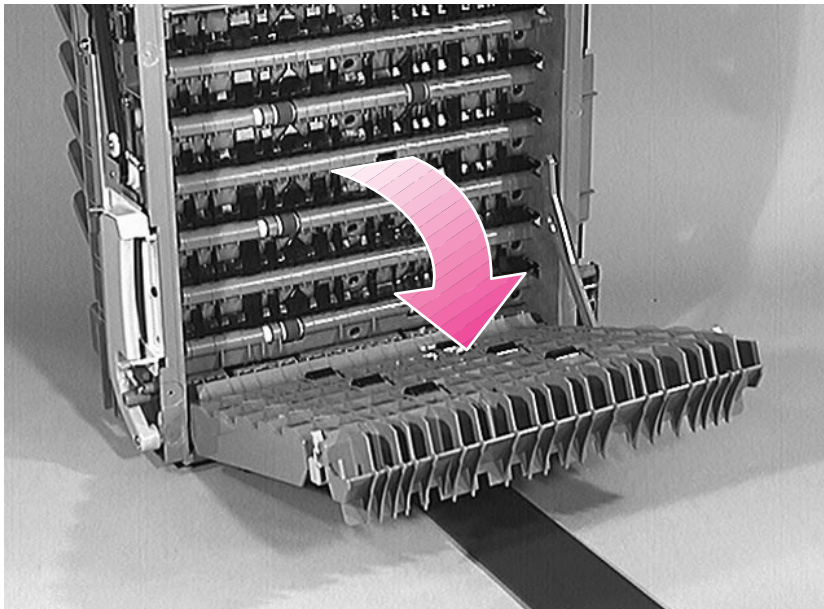

Figure 6-128 Right Door Assembly (Paper Path Cover) (3 of 5)

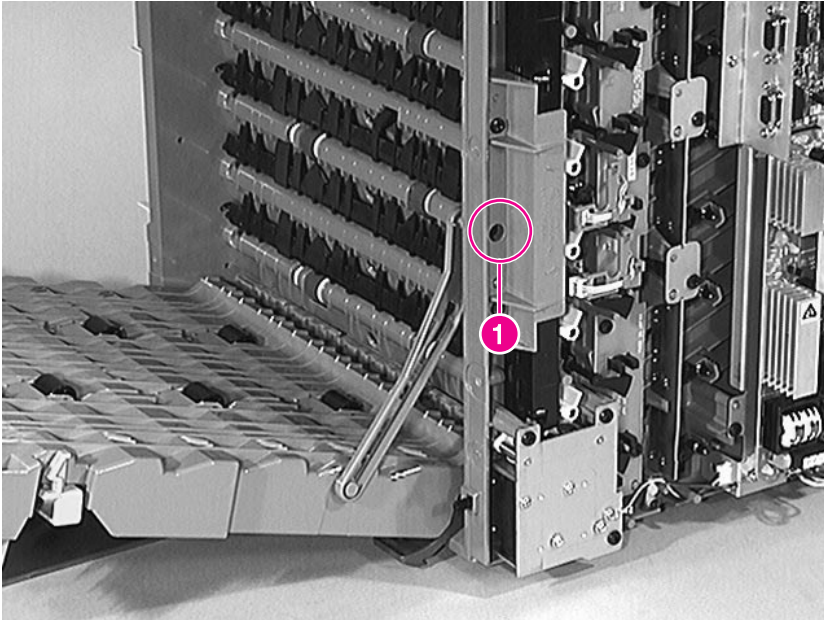

Figure 6-129 Right Door Assembly (Paper Path Cover) (3 of 5)

- 2 Remove the screw of the holding arm (callout 1) and release the arm from the Right Door Assembly.

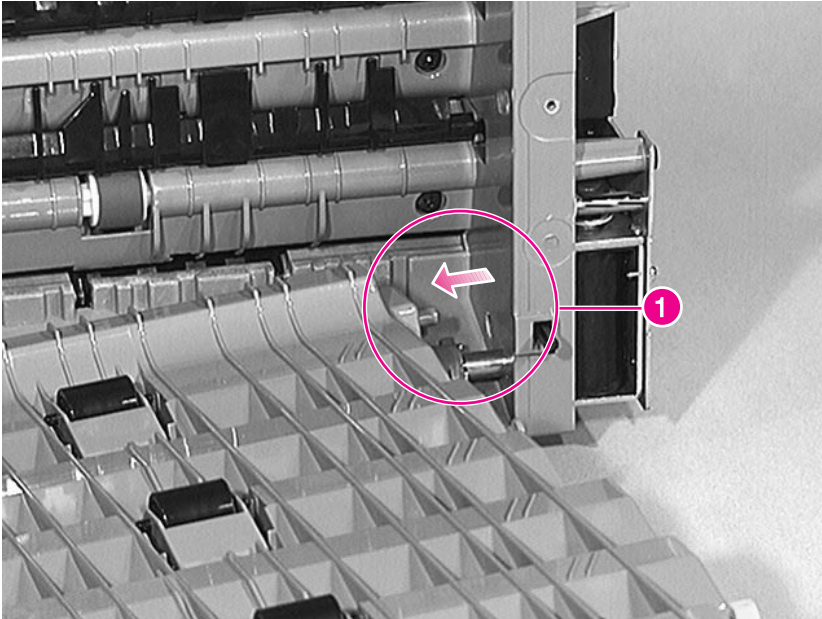

Figure 6-130 Right Door Assembly (Paper Path Cover) (4 of 5)

- 3 Release the plastic pin on the right end, and remove the paper path cover as shown in figure 6-130 (callout 1).

Face-down Bins

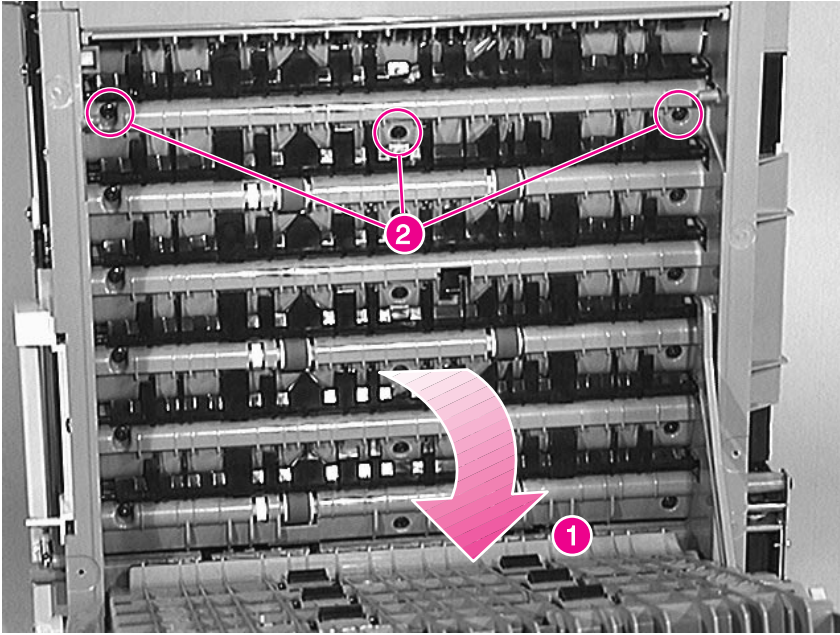

Figure 6-131 Face-down Bins (1 of 3)

Note

Bins 1, 3, and 5 each have one rear roller. Bins 2, 4, and 6 each have 2 rear rollers. The procedure for removing and replacing each of the bins is the same.

- 1 Remove the Front Cover (page 349) and the Back Cover (page 352).
- 2 Open the right door assembly (paper path cover) (callout 1)
Or
Remove the right door assembly to remove bin 5 or 6.
- 3 Remove 3 screws at the right side of the unit from the bin that needs to be replaced (callout 2).

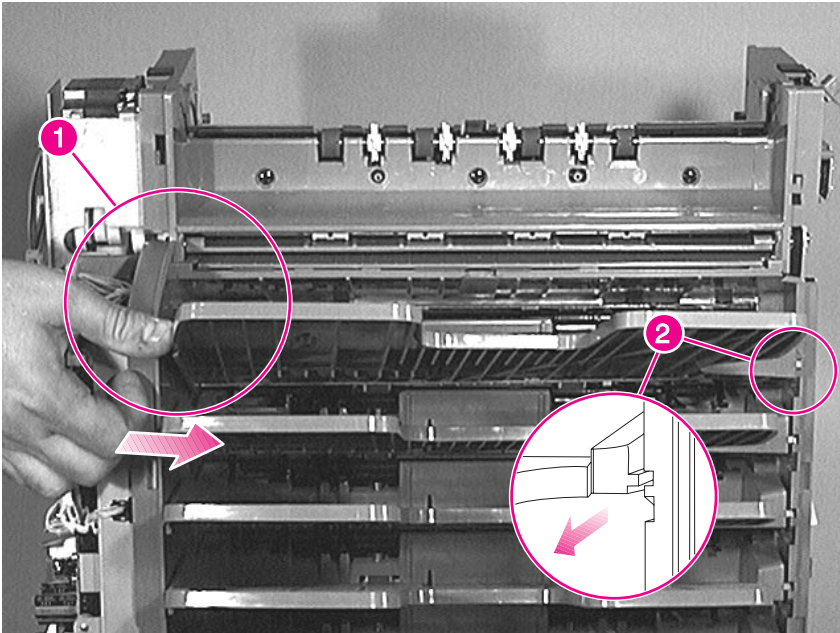

Figure 6-132 Face-down Bins (2 of 3)

- 4 From the back side of the device, push the bin as it is shown in callout 1.
- 5 Grasp the bin from the right side, and pull it straight out. Note the position of the tab (callout 2).

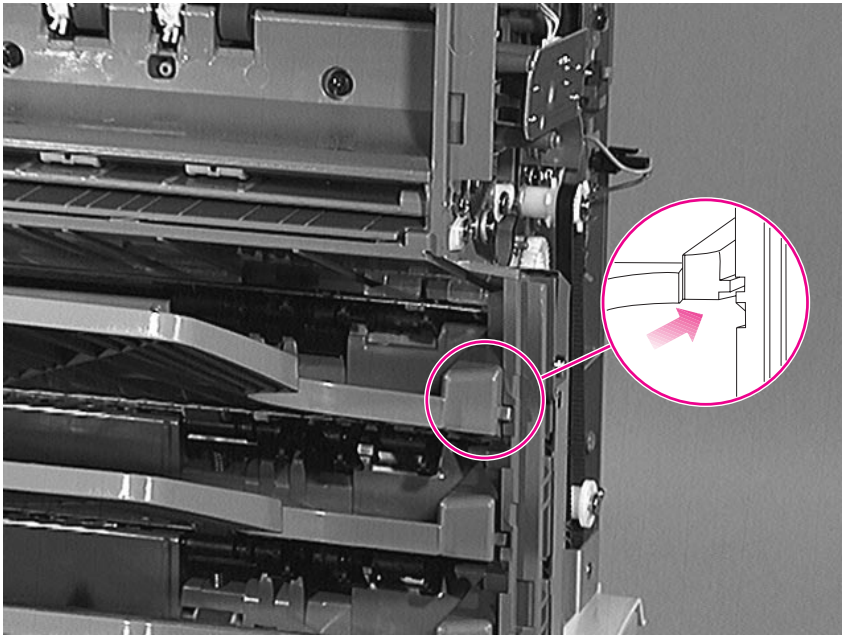

Figure 6-133 Face-down Bins (3 of 3)

To Reinstall:

- 1 Guide the empty bin sensor in the slot at the back side (figure 6-132, callout 1).
- 2 Make sure that the tabs are in place as shown in figure 6-133 callout 1.
- 3 Make sure that the holes for the 3 screws align with the holes of the tray.
- 4 Replace 3 screws (figure 6-131, callout 2).

Empty Bin Sensor PCA

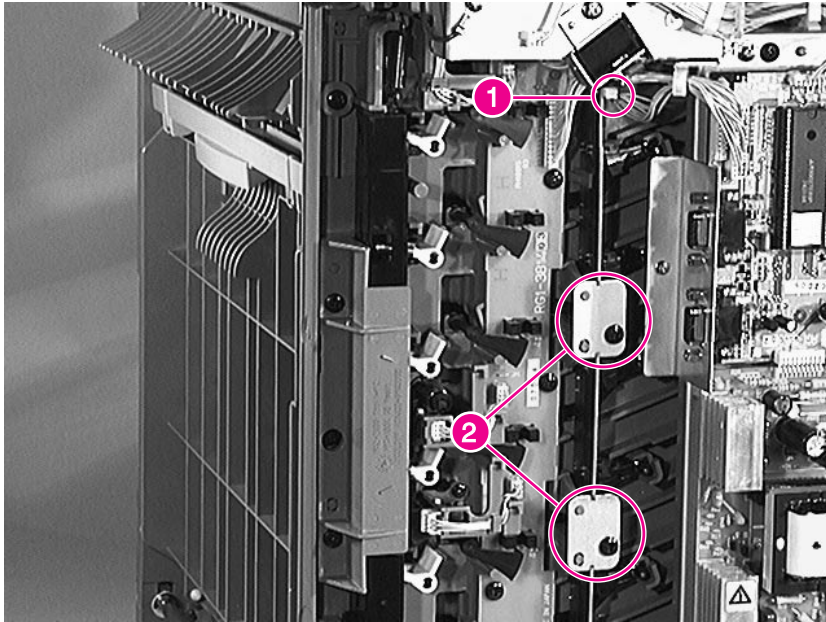

Figure 6-134 Empty Bin Sensor PCA (1 of 2)

- 1 Remove the Back Cover (page 352).
- 2 Unplug J305 (the topmost connector) from the Empty Bin Sensor PCA (callout 1).
- 3 Remove 2 screws and the metal plates that hold the Empty Bin Sensor PCA (callout 2).

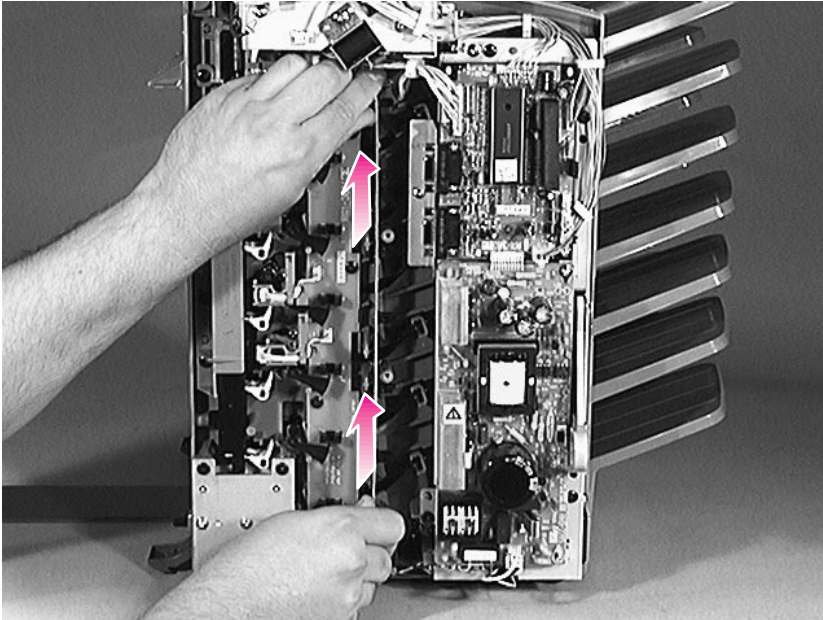

Figure 6-135 Empty Bin Sensor PCA (2 of 2)

- 4 Lift up the Empty Bin Sensor PCA to free it from the sensor flags, and pull it out as shown.

Full Bin and Interlock Sensor PCA

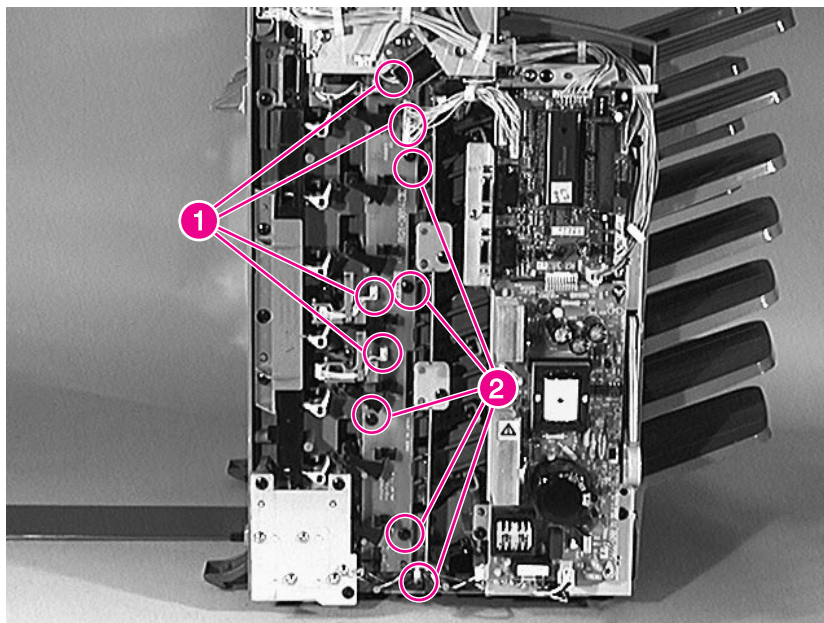

Figure 6-136 Full Bin and Interlock Sensor PCA (1 of 2)

- 1 Remove the Back Cover (page 352) and the Empty Bin Sensor PCA (page 367).
- 2 Unplug 4 connectors (J301, J302, J303, and J304). See callout 1.
- 3 Remove 4 screws from the Full Bin and Interlock Sensor PCA and one screw from the harness (callout 2).

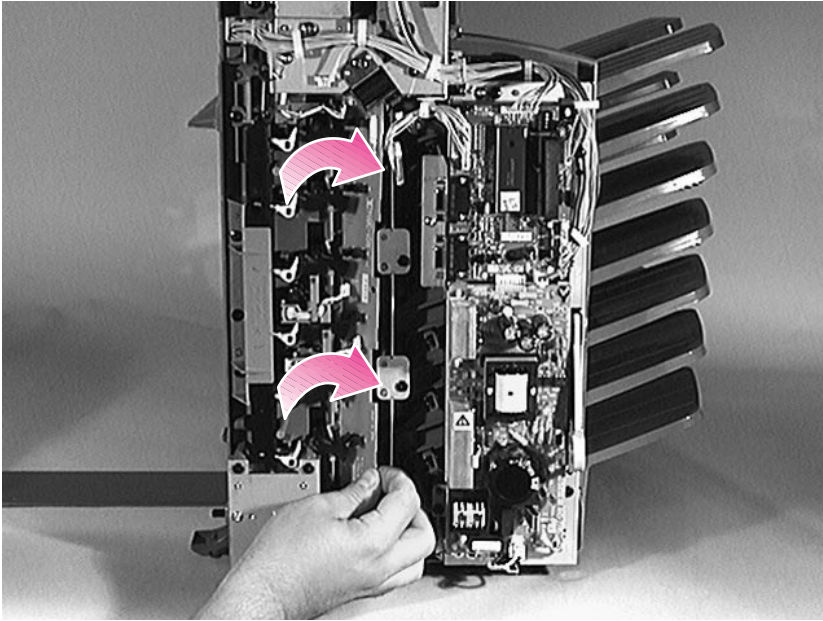

Figure 6-137 Full Bin and Interlock Sensor PCA (2 of 2)

- 4 Rotate the PCA toward the right, and then pull it out as shown.

Note

The reassembly procedure is the reverse of the disassembly procedure.

LED PCA

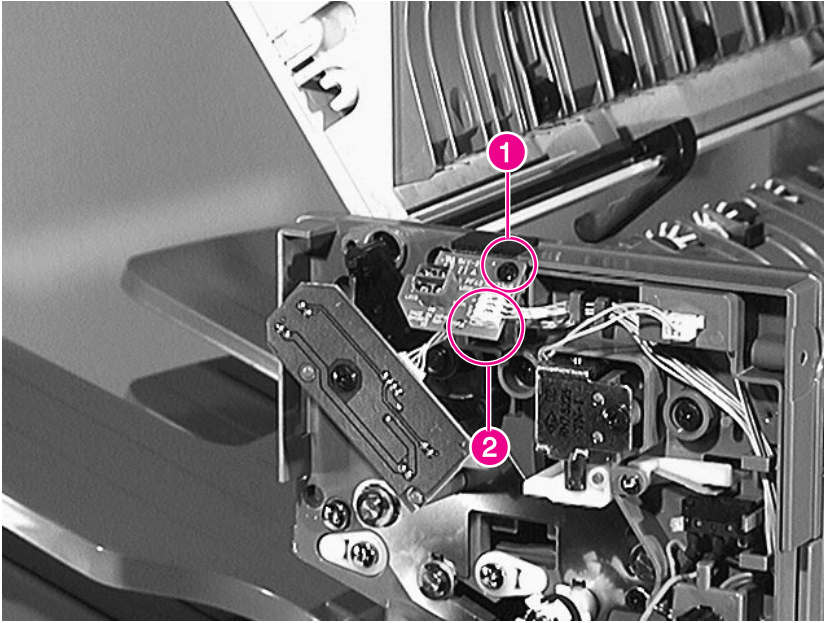

Figure 6-138 LED PCA

- 1 Remove the Front Cover (page 349).
- 2 Remove 1 screw (callout 1).
- 3 Unplug J307 from the LED PCA, and remove the LED PCA (callout 2).

Note

The reassembly procedure is the reverse of the disassembly procedure.

Face-up Sensors PCA

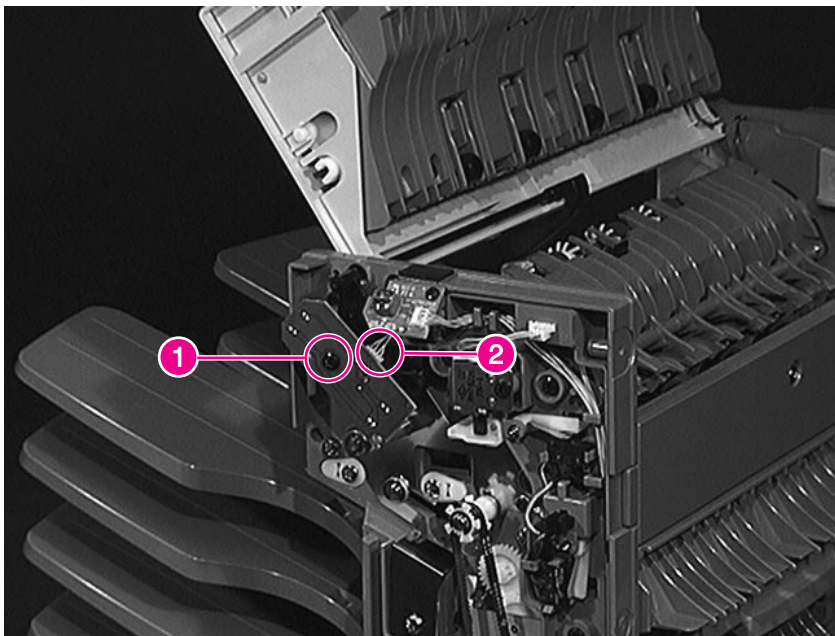

Figure 6-139 Face-up Sensors PCA

- 1 Remove the Front Cover (page 349).
- 2 Remove 1 screw (callout 1).
- 3 Unplug J306 from the Empty Bin Sensor PCA, and remove the Empty Bin Sensor PCA (callout 2).

Reversing Mechanism Motor

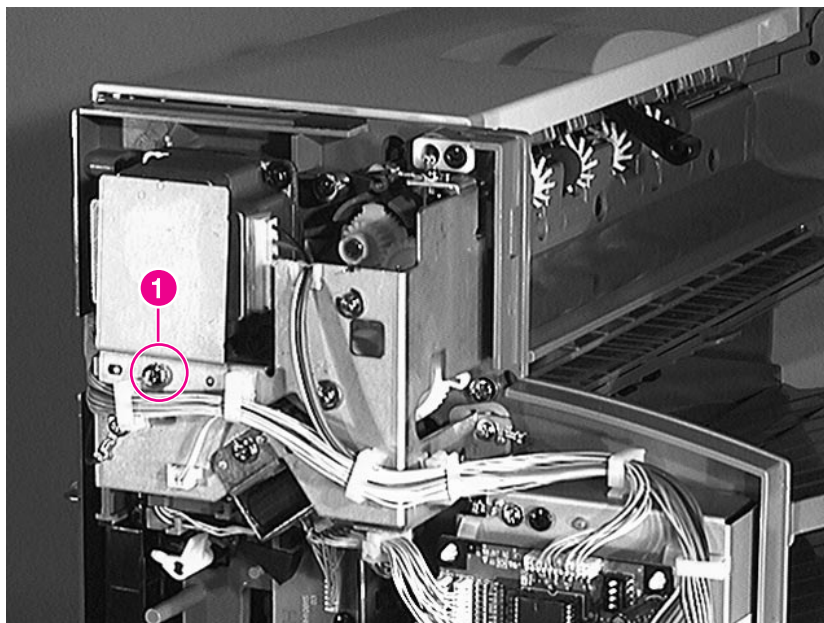

Figure 6-140 Reversing Mechanism Motor (1 of 2)

- 1 Remove the Back Cover (page 352).
- 2 Remove 1 screw from the metal plate (callout 1).

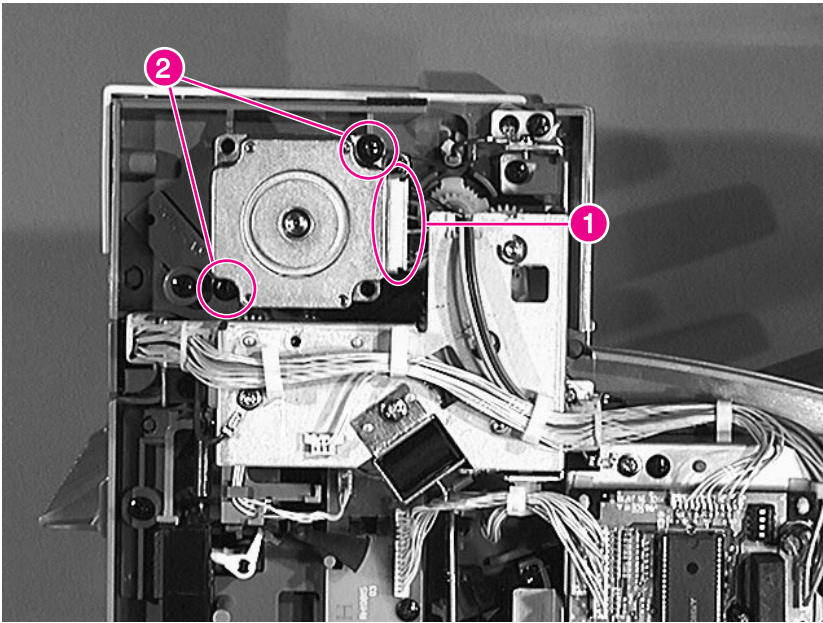

Figure 6-141 Reversing Mechanism Motor (2 of 2)

- 3 Unplug the motor's connector (callout 1).
- 4 Remove 2 screws (callout 2) and the motor.

CAUTION Do not damage the belt as you remove the motor.

Note The reassembly procedure is the reverse of the disassembly procedure.

Face-up/Diverter Assembly (Flipper)

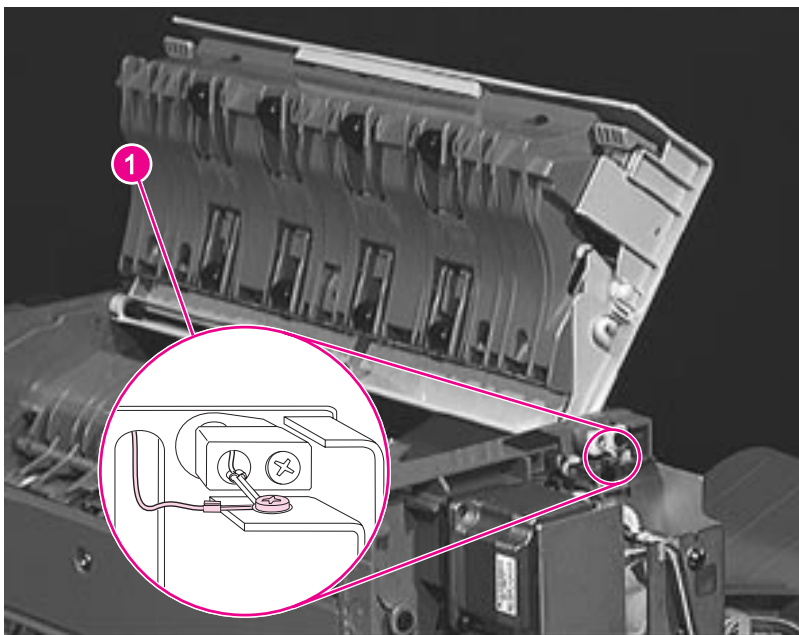

Figure 6-142 Face-up/Diverter Assembly (Flipper) (1 of 3)

- 1 Remove the Front Cover (page 349) and the Back Cover (page 352).
- 2 Open the Top Cover as shown.
- 3 Remove the grounding screw (callout 1) at the top back side (figure 6-142).

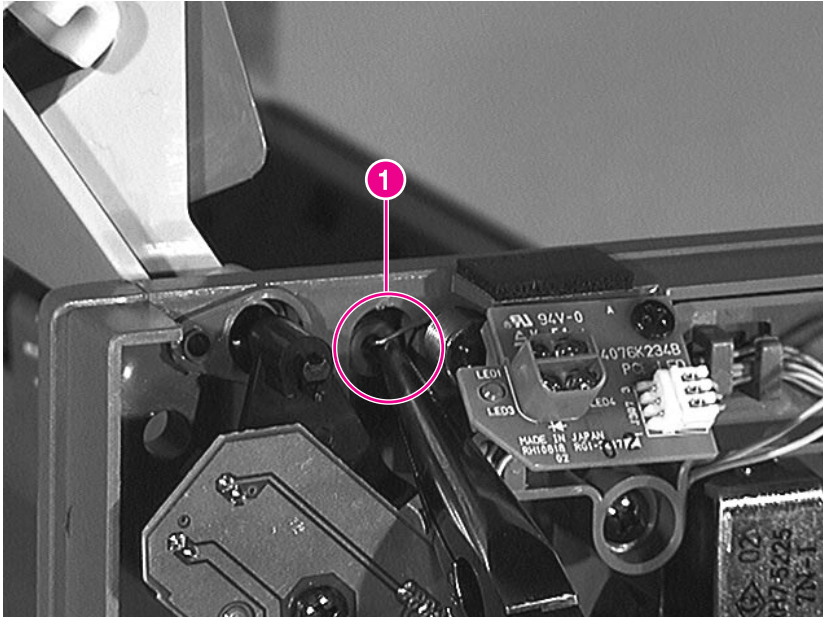
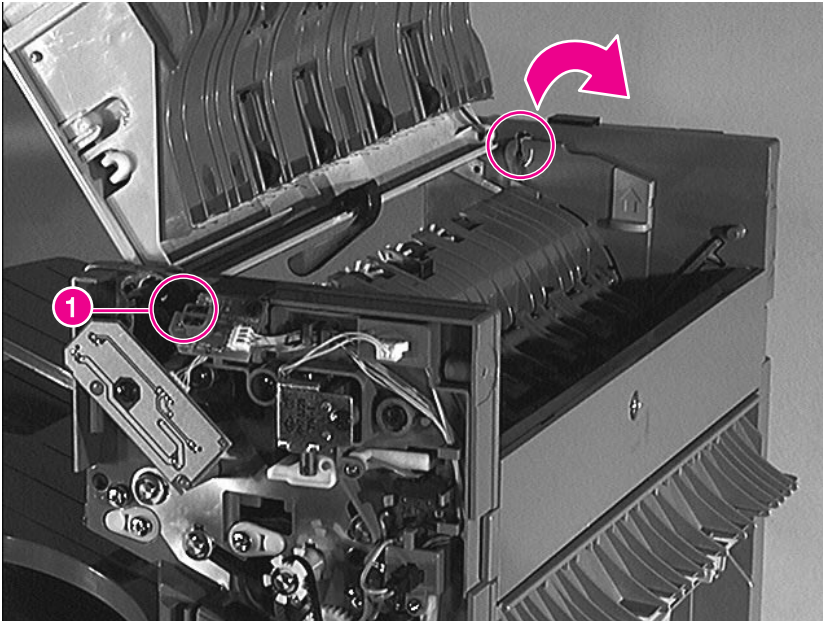

Figure 6-143 Face-up/Diverter Assembly (Flipper) (2 of 3)

- 4 Using pliers, release the springs at each end of the assembly (second figure on this page, callout 1).

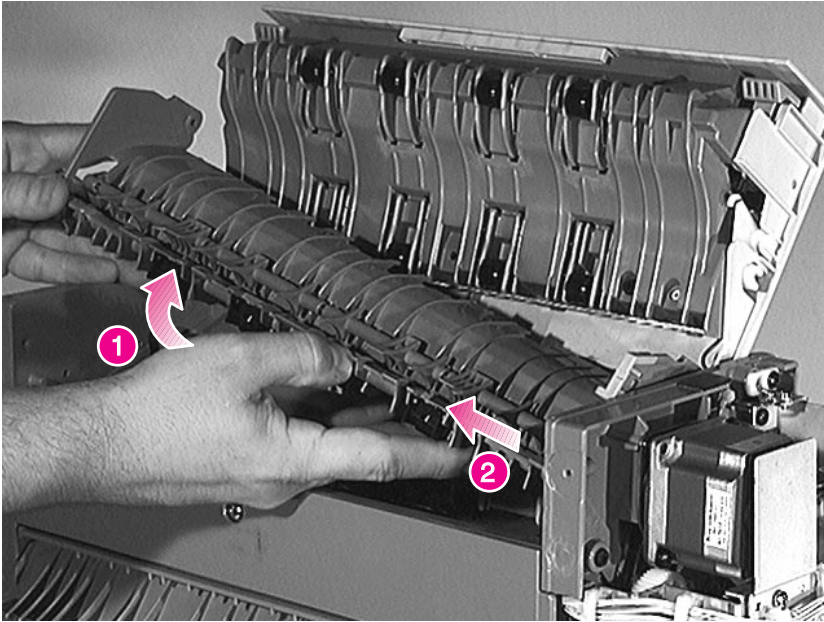

Figure 6-144 Face-up/Diverter Assembly (Flipper) (3 of 3)

- 5 Rotate the assembly upward, and then release side 1 (callout 1) first and side 2 (callout 2) second. Remove the assembly as shown.

Note The reassembly procedure is the reverse of the disassembly procedure.

Short Tray 7

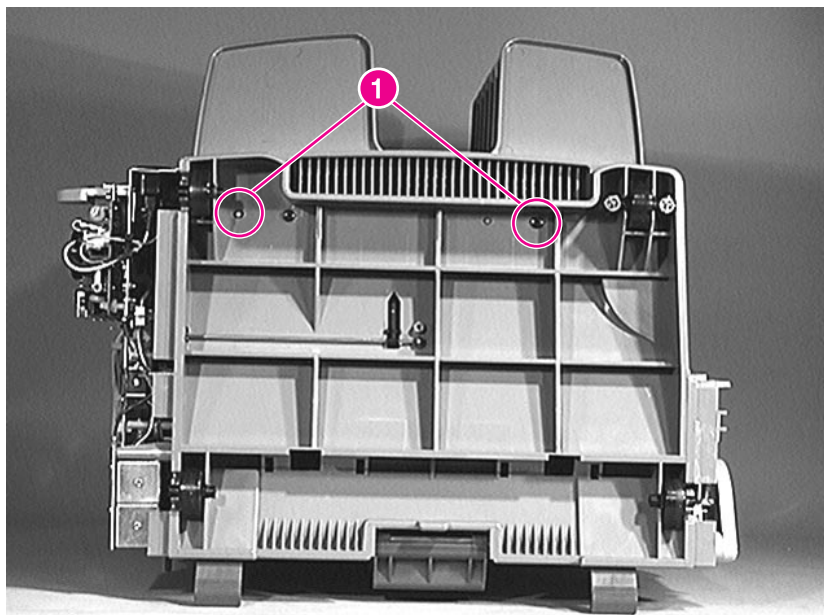

Figure 6-145 Short Tray 7

- 1 Place the 7-bin Tabletop Mailbox on its side as shown.
- 2 Remove 2 screws from the bottom (callout 1).
- 3 Remove the tray.

Note

The reassembly procedure is the reverse of the disassembly procedure.

Solenoid Reversing Mechanism

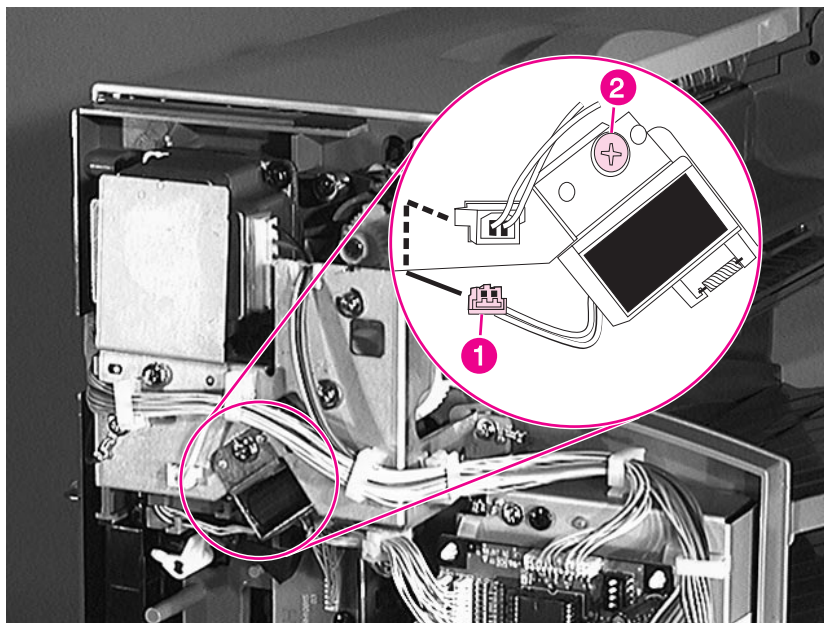

Figure 6-146 Solenoid Reversing Mechanism

- 1 Remove the Back Cover (page 352).
- 2 Unplug the cable from inside the bracket (callout 1).
- 3 Remove 1 screw and the solenoid (callout 2).

Note

The reassembly procedure is the reverse of the disassembly procedure.

Flipper Solenoid

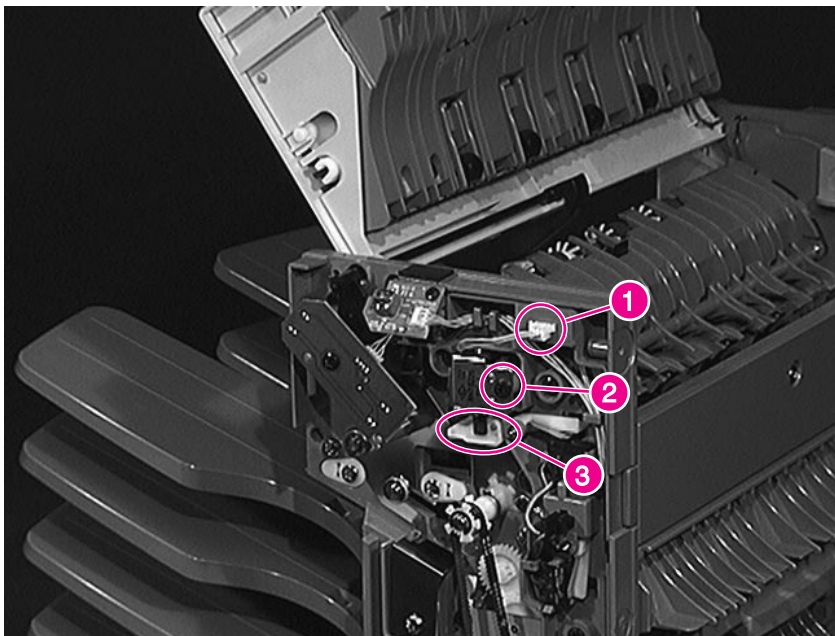

Figure 6-147 Flipper Solenoid

- 1 Remove the Front Cover (page 349).
- 2 Unplug the cable (callout 1).
- 3 Remove 1 screw and the solenoid (callout 2).
- 4 Release the solenoid along with the plastic actuator.

Handle

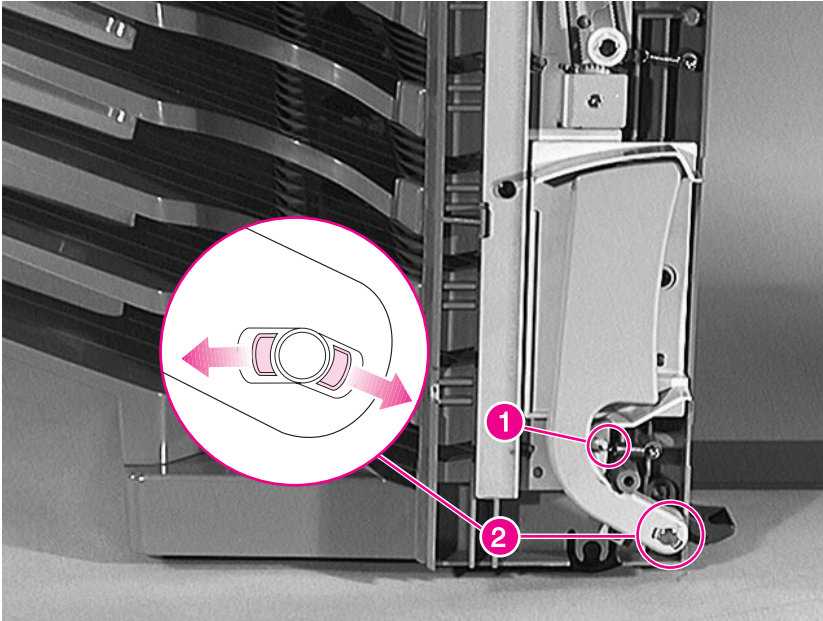

Figure 6-148 7-bin Tabletop Mailbox Handle

- 1 Release the left end of the spring (callout 1).
- 2 Release the 2 tabs (callout 2), and re the handle out.

To Reinstall:

Be sure the tabs of the handle are properly in place. Push the handle into place until it clicks.

Note

The reassembly procedure is the reverse of the disassembly procedure.

Latching Mechanism

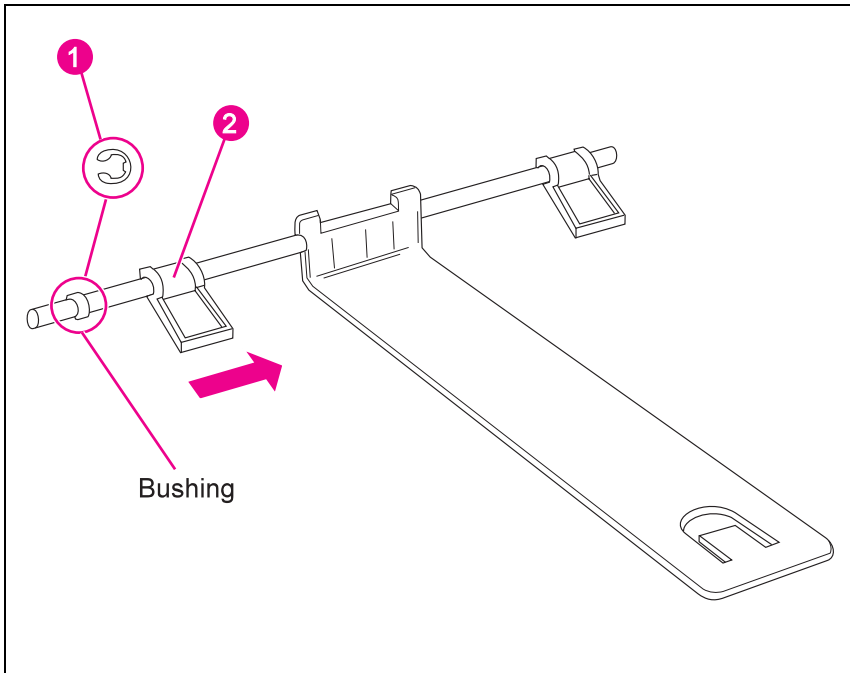

Figure 6-149 Latching Mechanism

- 1 Remove the 7-bin Tabletop Mailbox Handle (page 381).
- 2 Remove the E-clip in figure 6-149 (callout 1).
- 3 Move the bushing by sliding it over the shaft, to put it closer to the latching system (callout 2).
- 4 Slide the Latching Mechanism to the front of the device, and remove it.

To Reinstall:

Note

Guide the pin through the hole. First slide the shaft into the hole located at the front bottom of the device.

The tab on the bushing should be on the top during reinstallation.

Cover Latch

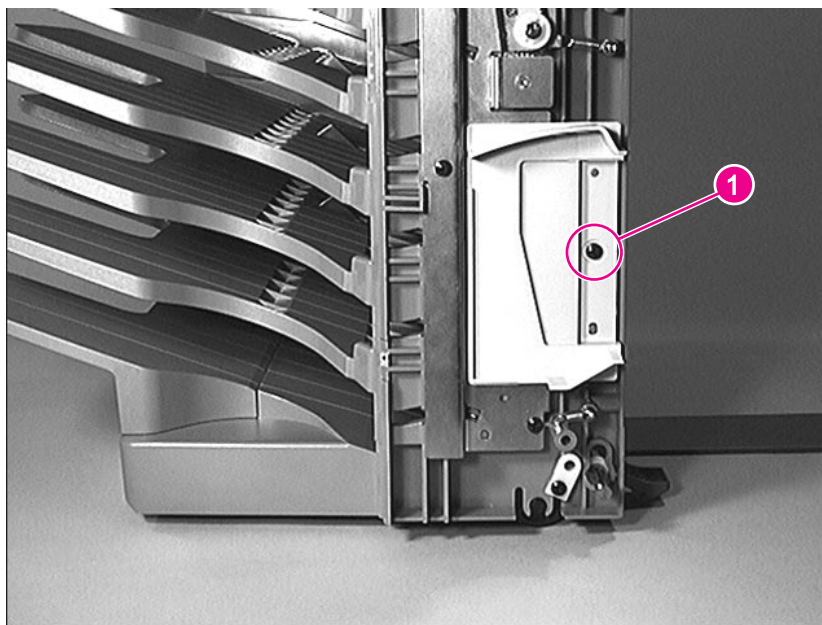

Figure 6-150 Cover Latch

- 1 Remove the 7-bin Tabletop Mailbox Handle (figure 6-148).
- 2 Remove 1 screw (callout 1), and remove the Cover Latch.

8-bin Mailbox Removal and Replacement

WARNING!

For the procedures in this section, the printer and all paper-handling devices must be unplugged. Before attempting to service an 8-bin Mailbox, unplug the power cord from the power source; otherwise, severe injury may result.

This printer and paper-handling devices may have sharp edges that could cause injury.

Note

Reinstallation is generally the reverse of the removal process. Carefully follow any additional instructions provided under “To Reinstall.”

Orientation - - - - -	385
Front and Back Covers - - - - -	386
Top Cover - - - - -	387
Power Supply - - - - -	388
Paper Bins and Blind Cover- - - - -	389
Flipper Assembly - - - - -	390
Delivery Head Motor - - - - -	393
Transport Belt Motor - - - - -	394
Input Paper Guide - - - - -	396
Metal Tape and Housing Assembly - - - - -	398
Controller PCA - - - - -	400
Anticurl Strings - - - - -	402
Delivery Head Assembly - - - - -	404
Interlock Switch - - - - -	409
Diagnostic LED PCA - - - - -	410
User Status LED PCA - - - - -	412
Adjustable and Fixed Casters - - - - -	414
Attachment Assembly - - - - -	415

Orientation

Figure 6-151 shows the orientation of the 8-bin Mailbox as it is referred to in this section.

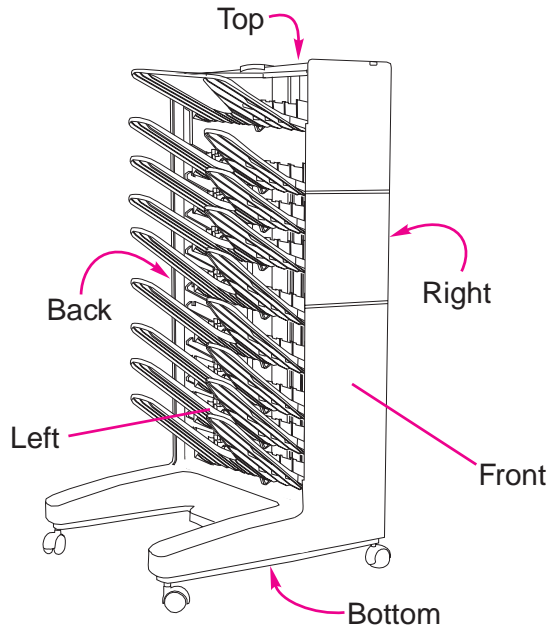

Figure 6-151 Orientation of the 8-bin Mailbox

Front and Back Covers

Note

The procedures for removing the Front and Back Covers are the same. However, before removing the Back Cover, disconnect the Power Supply cable that connects the 8-bin Mailbox Power Supply to the 8-bin Mailbox Controller PCA.

WARNING!

Unplug the power cord from the 8-bin Mailbox Power Supply, and then unplug the 8-bin Mailbox Power Supply cable from the 8-bin Mailbox Controller PCA.

- 1 Remove the 8-bin Mailbox from the printer (page 207).

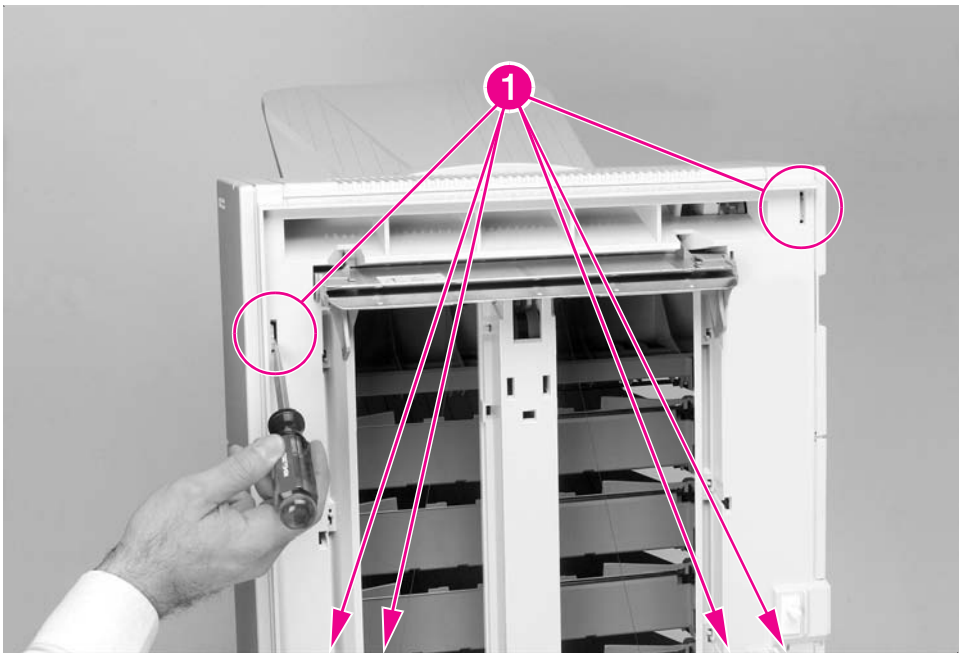

Figure 6-152 8-bin Mailbox Covers (Front and Back)

- 2 For each cover, using a small flat-blade screwdriver, release the 3 retaining tabs that secure the cover to the right side of the 8-bin Mailbox frame (callout 1), and rotate the cover outward to release it from the frame.

To Reinstall:

- 1 Insert the retaining tabs that secure each cover to the left side of the 8-bin Mailbox frame, and then snap the opposite edge of each cover into position.

Top Cover

- 1 Remove the Front and Back Covers from the 8-bin Mailbox (see Figure 6-152).

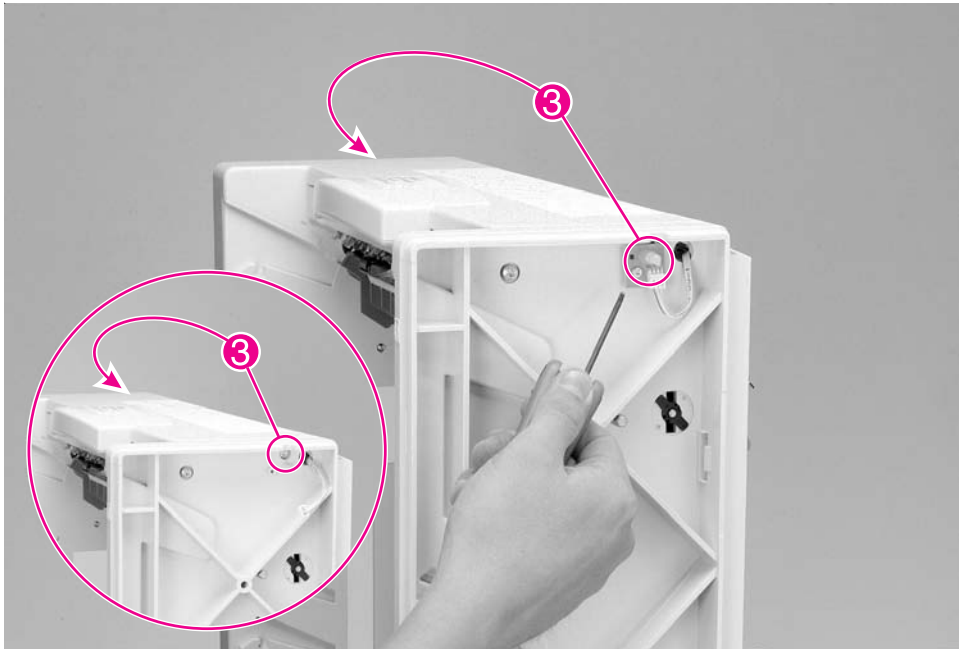

Figure 6-153 8-bin Mailbox Top Cover

- 2 Remove the 2 screws closest to the upper-right side of the 8-bin Mailbox: 1 screw on the front, next to the user LED, and the other at the back side of the 8-bin Mailbox frame (callout 3).
- 3 Slide the Top Cover to the left side of the device, and lift it up. See table 6-151 on page 385.

Power Supply

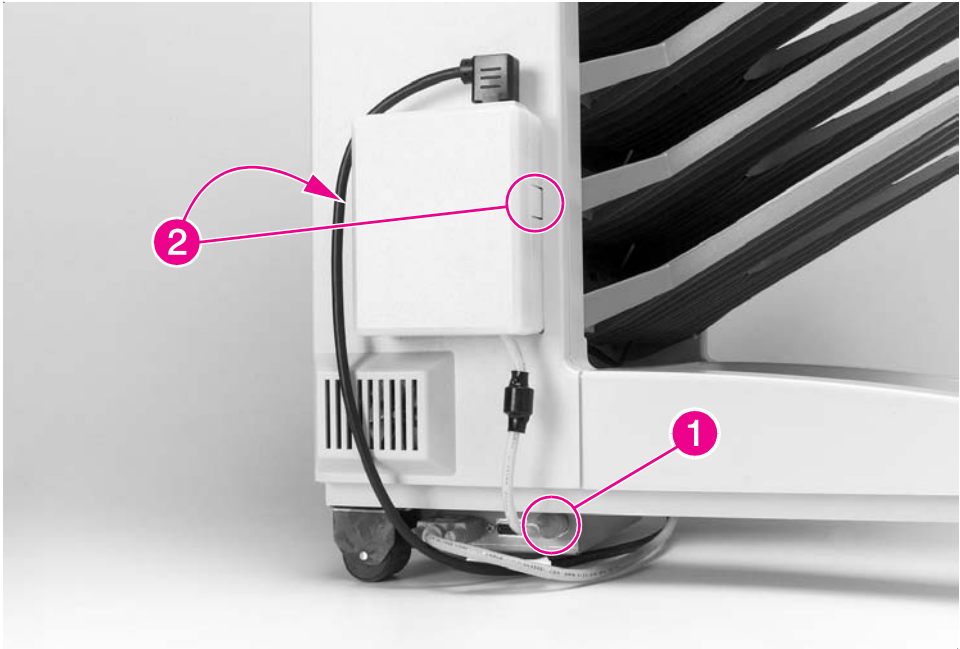

Figure 6-154 8-bin Mailbox Power Supply

- 1 Locate the cable that runs from the 8-bin Mailbox Power Supply down to the 8-bin Mailbox Controller PCA, and disconnect the cable from the Controller PCA (Figure 6-154, callout 1).
- 2 Remove the Power Supply from the Back Cover of the 8-bin Mailbox by pressing the plastic retaining tabs that are on each side of the Power Supply (callout 2).

To Reinstall:

- 1 Align the Power Supply with the mounting holes that are on the Back Cover so that the retaining tabs on the Power Supply (callout 2) fit into their respective slots.
- 2 Reconnect the Power Supply Cable to the 8-bin Mailbox Controller PCA (callout 1).

Paper Bins and Blind Cover

The procedure for removing a paper bin and the Blind Cover is the same. Each bin rests in its labeled slot.



Figure 6-155 8-bin Mailbox Paper Bins and Blind Cover

- 1 Remove the Face-up Bin first. Lift up on the outer edge of the bin to clear the retaining notch in the frame, and then pull the bin away from the 8-bin Mailbox frame (callout 1).
- 2 Remove the Blind Cover.
- 3 Remove each Face-down Bin, starting at the top and working down in sequence.

To Reinstall:

- 1 Slide a bin into its designated slot, and then lower the bin into the retaining notch in the frame.
- 2 Replace the paper bins, beginning with the bottom Face-down Bin and continuing upward in order.
- 3 Place the Blind Cover between Face-down Bin 1 and the Face-up Bin.

Flipper Assembly

- 1 Remove all the paper bins and the Blind Cover from the 8-bin Mailbox (see Figure 6-155).
- 2 Remove the Front, Back, and Top Covers from the 8-bin Mailbox (see Figure 6-152 and Figure 6-153).

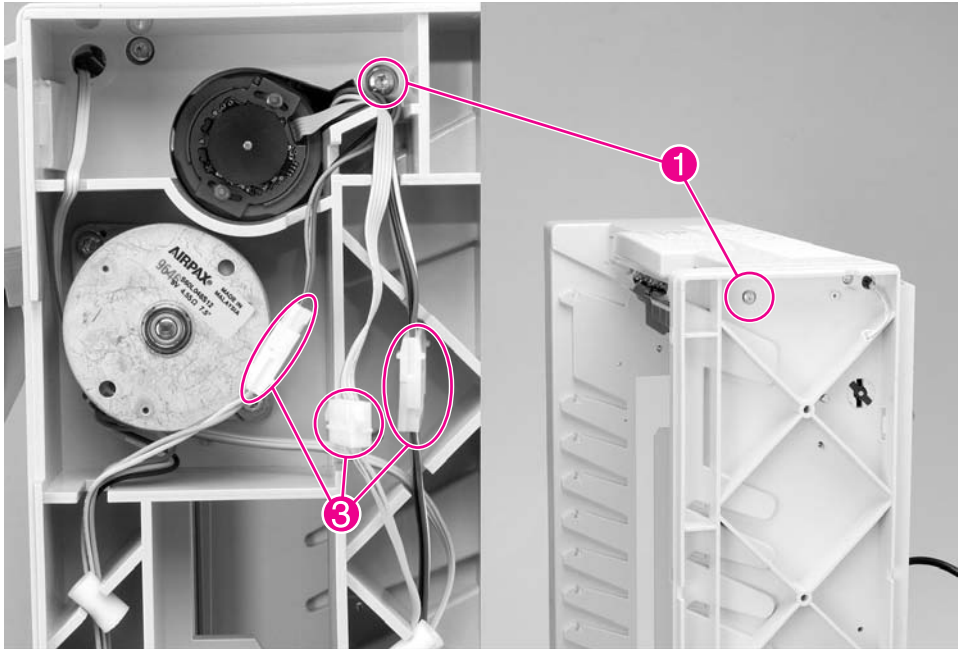

Figure 6-156 8-bin Mailbox Flipper Assembly (1 of 3)

- 3 Remove the 2 screws closest to the upper-left side of the 8-bin Mailbox: 1 screw on the front and back sides of the 8-bin Mailbox frame (Figure 6-156, callout 1).

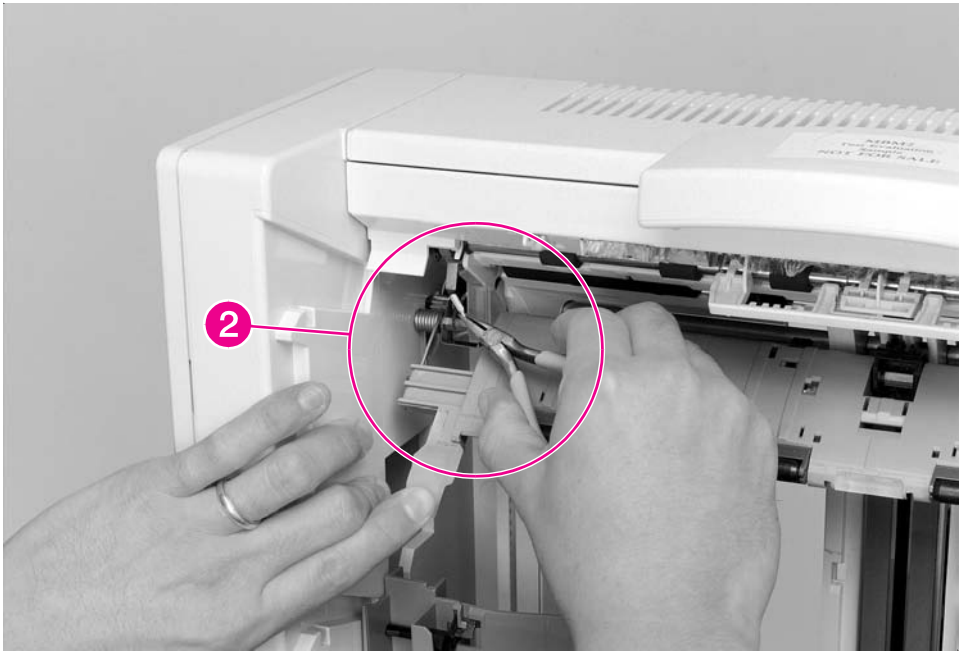

Figure 6-157 8-bin Mailbox Flipper Assembly (2 of 3)

- 4 Hold down the Jam Access Door while unplugging the ground wire that runs from the Input Paper Guide to the Flipper Motor (Figure 6-157, callout 2).
- 5 Unplug the Flipper Assembly's 3 cables from the connectors that are located on the 8-bin Mailbox unit's back side (Figure 6-156, callout 3).
- 6 Using a flat-blade screwdriver, release the plastic retaining tab that secures the Flipper Assembly to the top of the 8-bin Mailbox frame (Figure 6-158, callout 4).

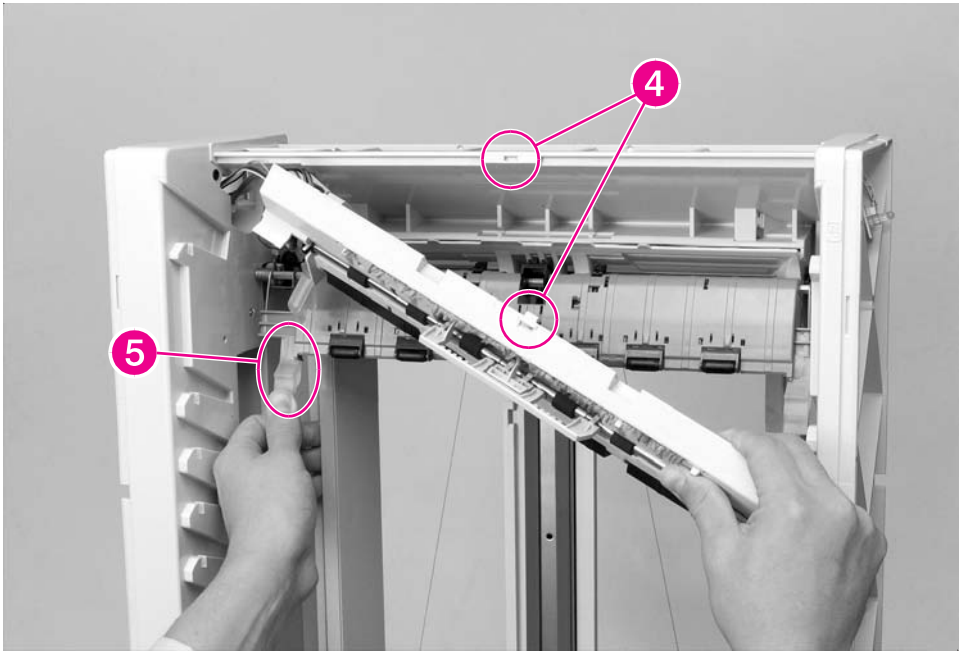

Figure 6-158 8-bin Mailbox Flipper Assembly (3 of 3)

- 7 Hold down the Jam Access Door, and pull out the Flipper Assembly (Figure 6-158, callout 5).

To Reinstall:

- 1 Hold down the Jam Access Door to reconnect the ground wire to the Flipper Motor (Figure 6-157, callout 2).
- 2 Route the Flipper Assembly's 3 cables through the back side of the 8-bin Mailbox frame and reconnect the 3 cables to the connectors (Figure 6-156, callout 3).

CAUTION

Do not over-tighten the screws that secure the Flipper Assembly to the 8-bin Mailbox frame. The nuts in the Flipper Assembly could rotate in their slots.

Delivery Head Motor

- 1 Remove the Back Cover from the 8-bin Mailbox (see Figure 6-152).

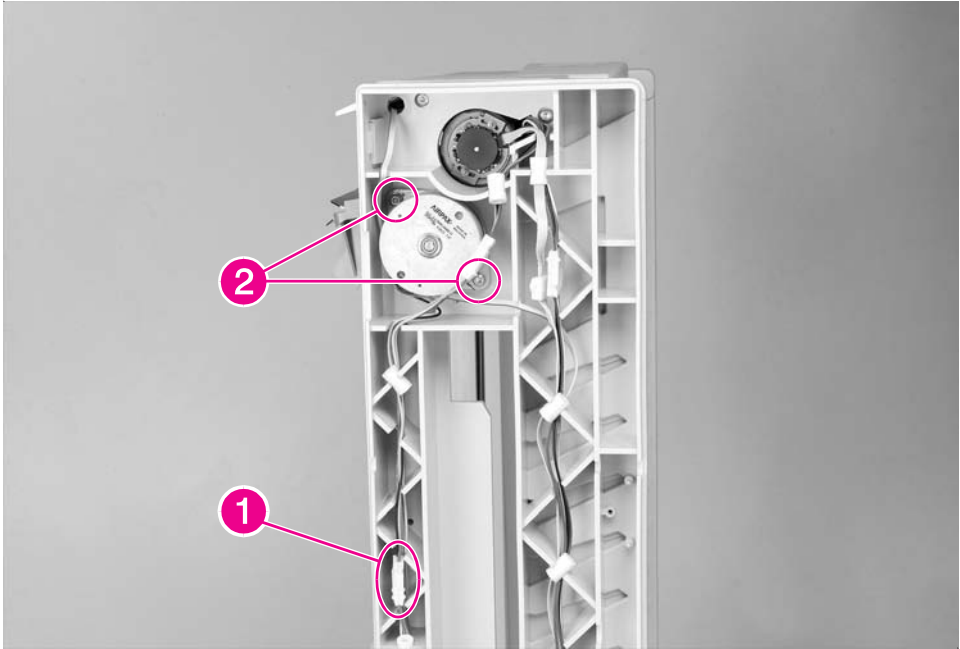

Figure 6-159 8-bin Mailbox Delivery Head Motor

- 2 Locate the cable that runs from the Delivery Head Motor down to the 8-bin Mailbox Controller PCA, and disconnect the cable from the connector in the middle of the 8-bin Mailbox frame (Figure 6-159, callout 1).
- 3 Remove the 2 screws that secure the Delivery Head Motor to the 8-bin Mailbox frame (callout 2).
- 4 Pull the Delivery Head Motor away from the 8-bin Mailbox frame.

To Reinstall:

- 1 Position the motor in the 8-bin Mailbox frame so that the cable grommets face down.
- 2 Reconnect the motor's cable to the connector in the middle of the frame (callout 1).

Transport Belt Motor

- 1 Remove the Back Cover from the 8-bin Mailbox (see Figure 6-152).
- 2 Remove all the paper bins and the Blind Cover from the 8-bin Mailbox (see Figure 6-155).
- 3 Release the Controller PCA Assembly from the bottom of the 8-bin Mailbox frame (see figure 6-165 on page 400, steps 1 through 7).

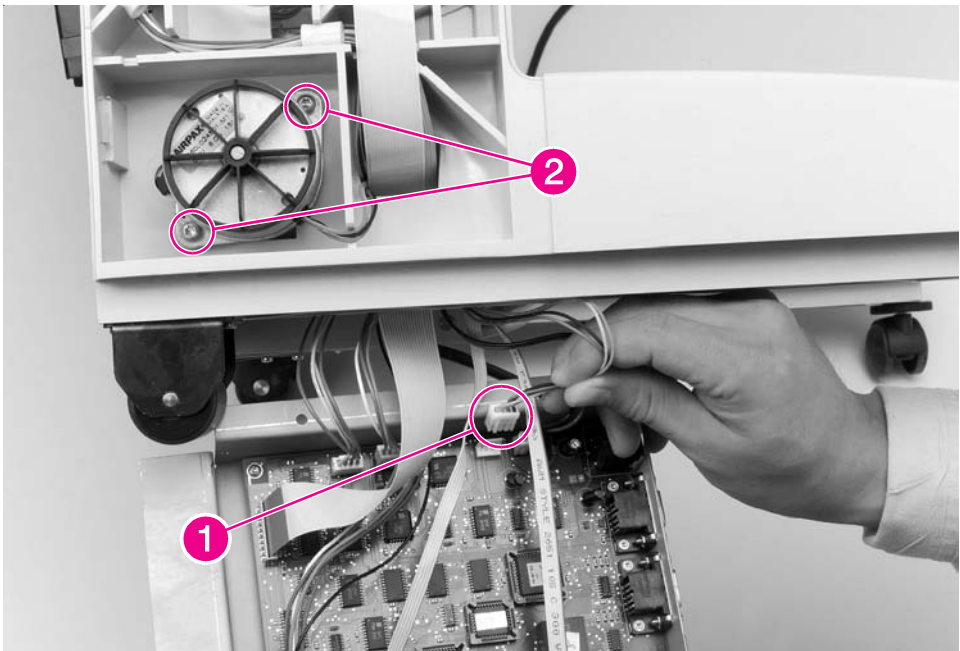

Figure 6-160 8-bin Mailbox Transport Belt Motor

- 4 Locate the cable that runs from the Transport Belt Motor to the 8-bin Mailbox Controller PCA, and disconnect the cable from the J8 connector on the Controller PCA (Figure 6-160, callout 1).
- 5 Remove the 2 screws (and washers) that secure the Transport Belt Motor to the 8-bin Mailbox frame (Figure 6-160, callout 2).

CAUTION

When pulling out the motor, be careful to not damage the internal drive belt.

- 6 Gently pull out the motor.

To Reinstall:

- 1** Reroute the cable on the Transport Belt Motor behind the flat cable, and connect it to the J8 connector on the 8-bin Mailbox Controller PCA (callout 1).
- 2** Reinstall the 8-bin Mailbox Controller PCA Assembly (see Figure 6-165).
- 3** Replace the internal drive belt onto the Transport Belt Motor's gear before replacing and tightening the screws that secure the motor to the frame.

Input Paper Guide

- 1 Remove the 8-bin Mailbox from the printer.
- 2 Remove the Face-up Bin and the Blind Cover from the 8-bin Mailbox (see Figure 6-155).

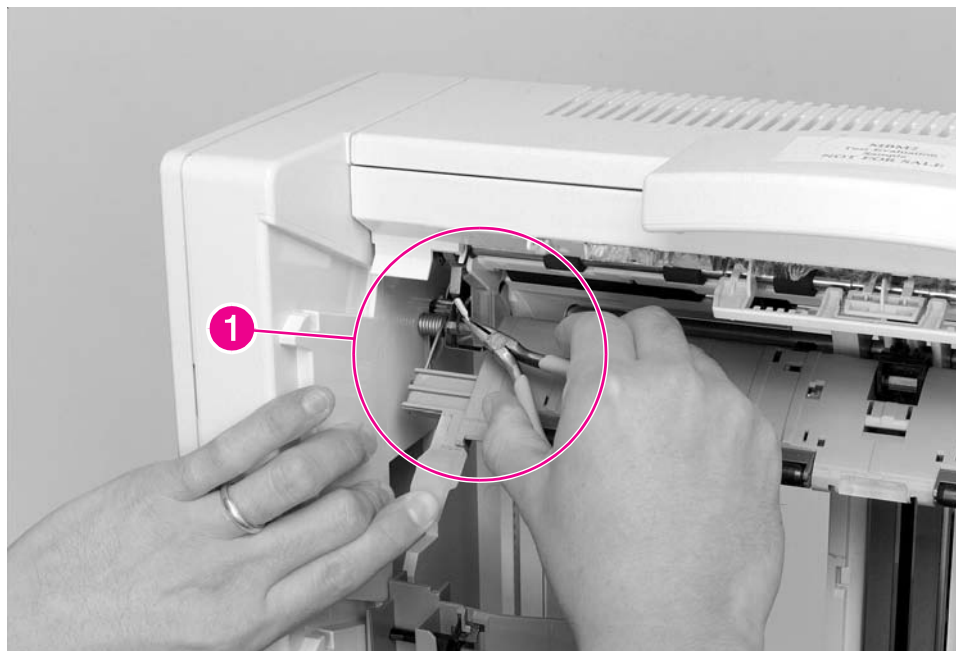

Figure 6-161 8-bin Mailbox Input Paper Guide (1 of 2)

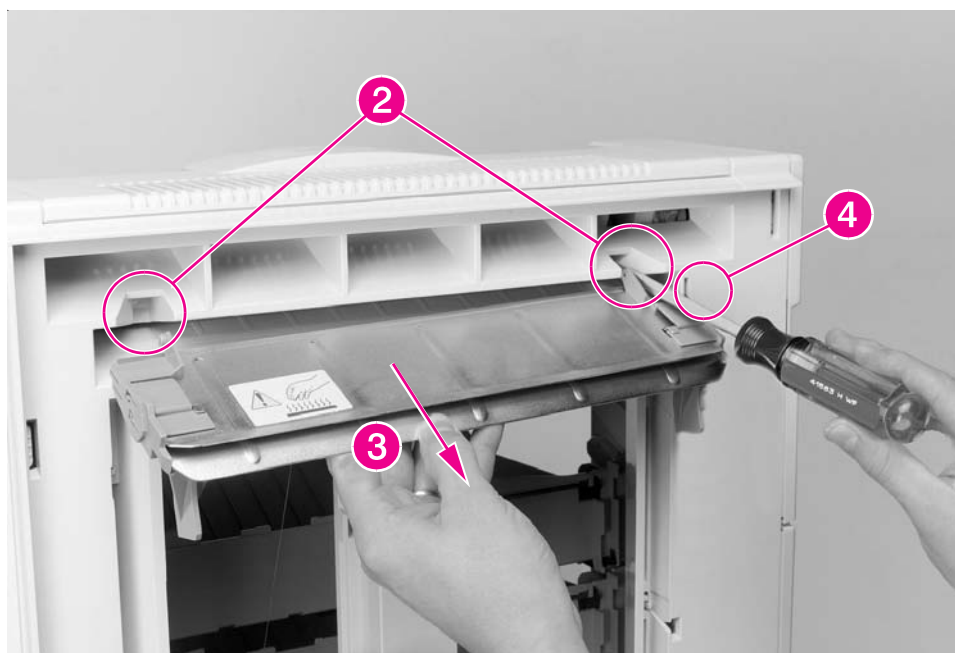

Figure 6-162 8-bin Mailbox Input Paper Guide (2 of 2)

- 3 Hold down the Jam Access Door while unplugging the ground wire that runs from the Input Paper Guide to the Flipper Motor (Figure 6-161, callout 1).
- 4 Use a flat-blade screwdriver to release the retaining tabs that secure the Input Paper Guide to the upper-right side of the 8-bin Mailbox (Figure 6-162, callout 2).
- 5 Pull the Input Paper Guide free of the frame (callout 3) while routing the ground wire that connects to the end of the paper guide through the wire's access hole (callout 4).

To Reinstall:

- 1 Reroute the ground wire through its access hole (Figure 6-162, callout 4).
- 2 Reconnect the ground wire to the Flipper Motor (Figure 6-161, callout 1).
- 3 Replace the Face-up Bin and the Blind Cover (see Figure 6-155).

Metal Tape and Housing Assembly

- 1 Remove all the paper bins and the Blind Cover from the 8-bin Mailbox (see Figure 6-155).

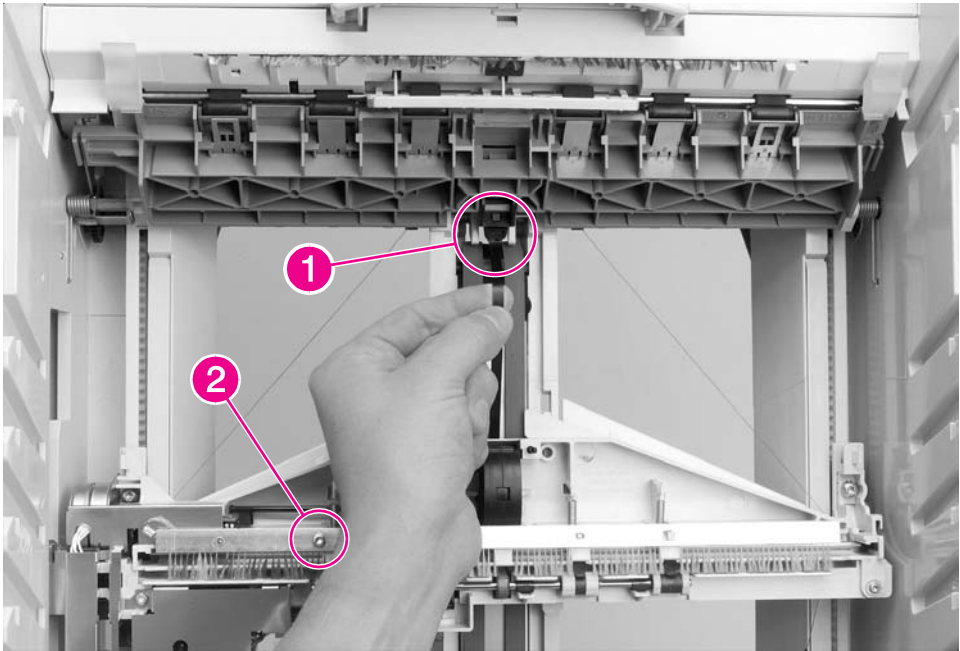

Figure 6-163 8-bin Mailbox Metal Tape and Housing Assembly (1 of 2)

WARNING!

The Metal Tape's sharp edges can cause serious injury. When rewinding the Metal Tape into its housing, hold the tape securely and rewind it slowly.

- 2 With the Delivery Head Assembly at the top of the 8-bin Mailbox, hold the Metal Tape near the end, and push and release the retainer tab that secures the end of the tape to the top of the 8-bin Mailbox frame (Figure 6-163, callout 1). Then let the tape slowly rewind into its housing.
- 3 Remove the 1 screw that secures the Static Brush to the Delivery Head Assembly (callout 2), and then move the Static Brush out of the way.
- 4 Lower the Delivery Head Assembly halfway to the stops.

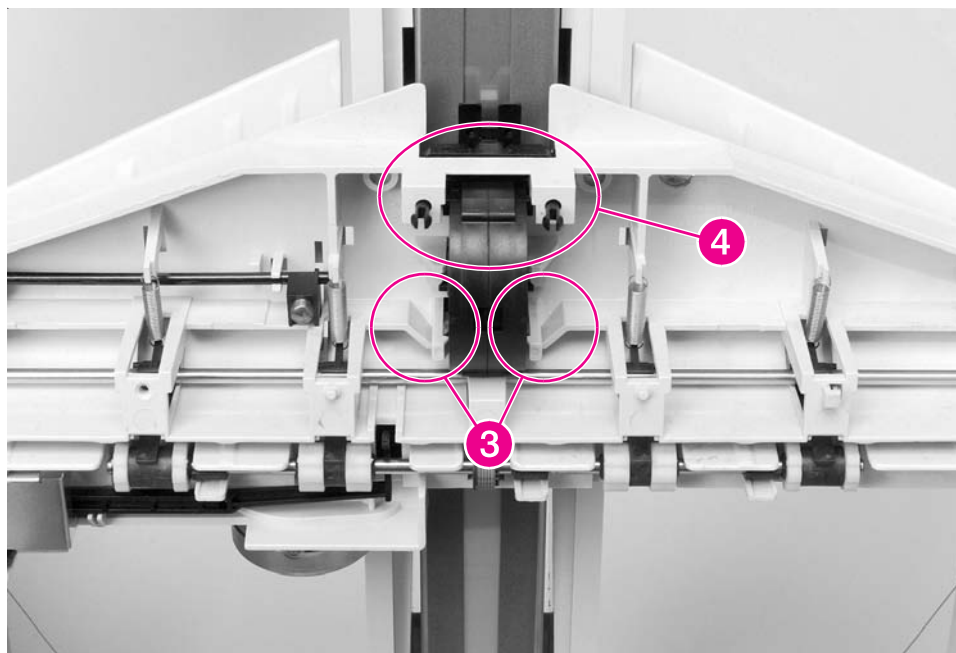

Figure 6-164 8-bin Mailbox Metal Tape and Housing Assembly (2 of 2)

- 5 Using a flat-blade screwdriver, release the plastic retaining tabs located on each side of the tape housing (Figure 6-164, callout 3).
- 6 Gently pull on the Delivery Head Assembly to remove the end of the tape from behind the rollers that hold the tape in its track (callout 4). Then pull the tape housing toward you to remove it.

To Reinstall:

- 1 Thread the end of the Metal Tape behind the rollers (callout 4), and then pull the end of the tape to the top of the 8-bin Mailbox and reinsert it into place (Figure 6-163, callout 1).
- 2 Use the guide pins to reinstall the tape housing (Figure 6-164, callout 3). When the housing is correctly positioned, it will click into place.
- 3 Reinstall the static brush (Figure 6-163, callout 1).

Controller PCA

- 1 Remove the 8-bin Mailbox from the printer.

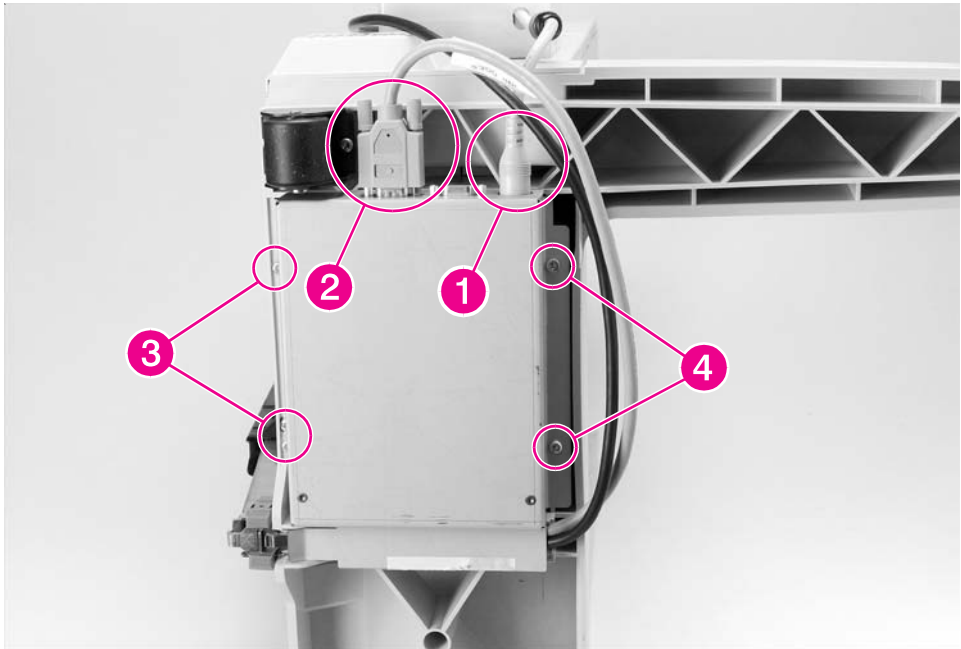

Figure 6-165 8-bin Mailbox Controller PCA (1 of 2)

- 2 Locate the power cable that runs from the 8-bin Mailbox Power Supply down to the 8-bin Mailbox Controller PCA, and disconnect the cable from the Controller PCA (Figure 6-165, callout 1).
- 3 Disconnect the C-link cable from the 8-bin Mailbox Controller PCA (callout 2).
- 4 Remove all paper bins and the Blind Cover from the 8-bin Mailbox (see Figure 6-155).
- 5 Carefully lay the 8-bin Mailbox onto its front side.
- 6 Loosen the 1 grounding screw and the 2 self-tapping screws that secure the Controller PCA to the bottom-right side of the 8-bin Mailbox frame (callout 3).
- 7 Remove the 2 self-tapping screws that secure the Controller PCA to the bottom-left side of the 8-bin Mailbox frame (callout 4). One of the screws is connected to a grounding cable.
- 8 Open the metal box to reveal the Controller PCA.

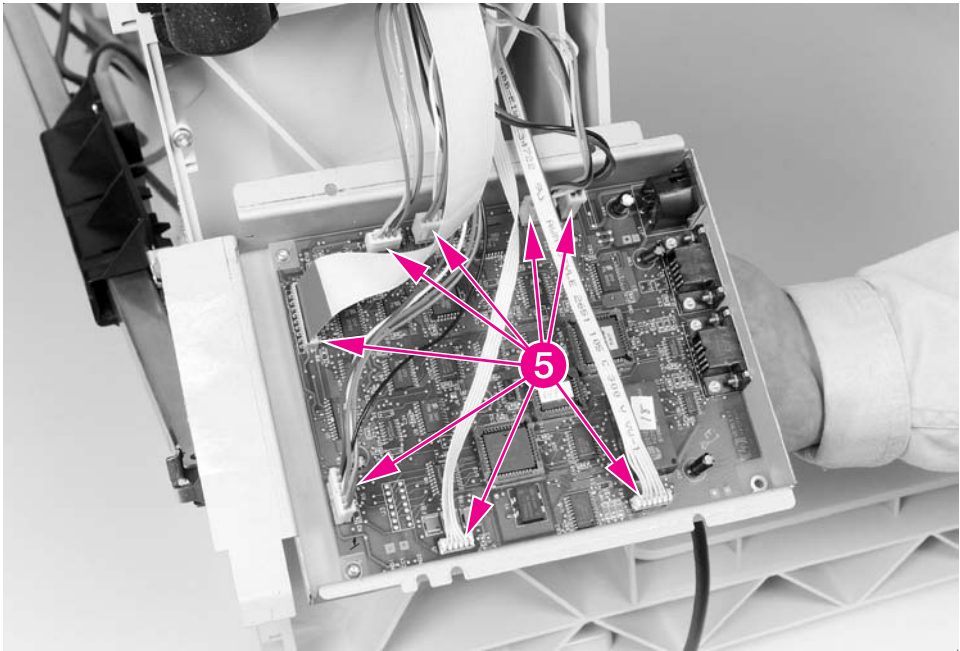

Figure 6-166 8-bin Mailbox Controller PCA (2 of 2)

- 9 Disconnect the 8 cables from the Controller PCA (Figure 6-166, callout 5).

To Reinstall:

- 1 Reconnect the 8 cables to the connectors on the 8-bin Mailbox Controller PCA (callout 5).
- 2 Be sure to reinstall the grounding cable beneath its corresponding screw.

Anticurl Strings

- 1 Remove the Back Cover, all the paper bins, and the Blind Cover from the 8-bin Mailbox (see Figure 6-152 and Figure 6-155).

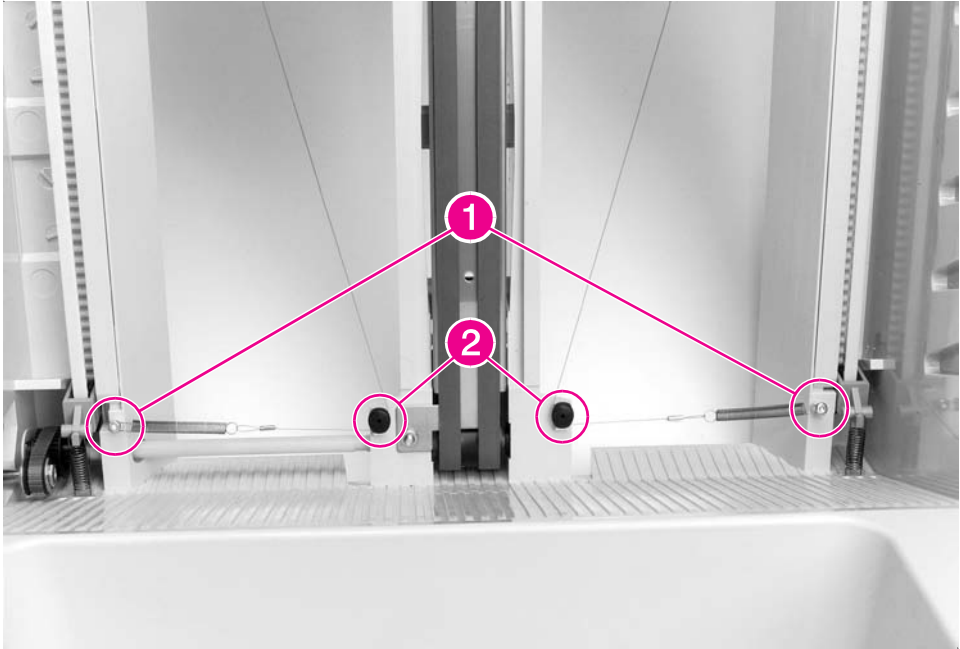

Figure 6-167 8-bin Mailbox Anticurl Strings (1 of 2)

- 2 At the lower-left side of the 8-bin Mailbox frame, locate the Tension Springs on the Anticurl Strings, and remove the 2 screws that secure the springs to the frame (Figure 6-167, callout 1).
- 3 Remove the Anticurl Strings from the lower pulleys (callout 2).
- 4 Remove the Delivery Head Assembly from the 8-bin Mailbox frame (see Figure 6-169).

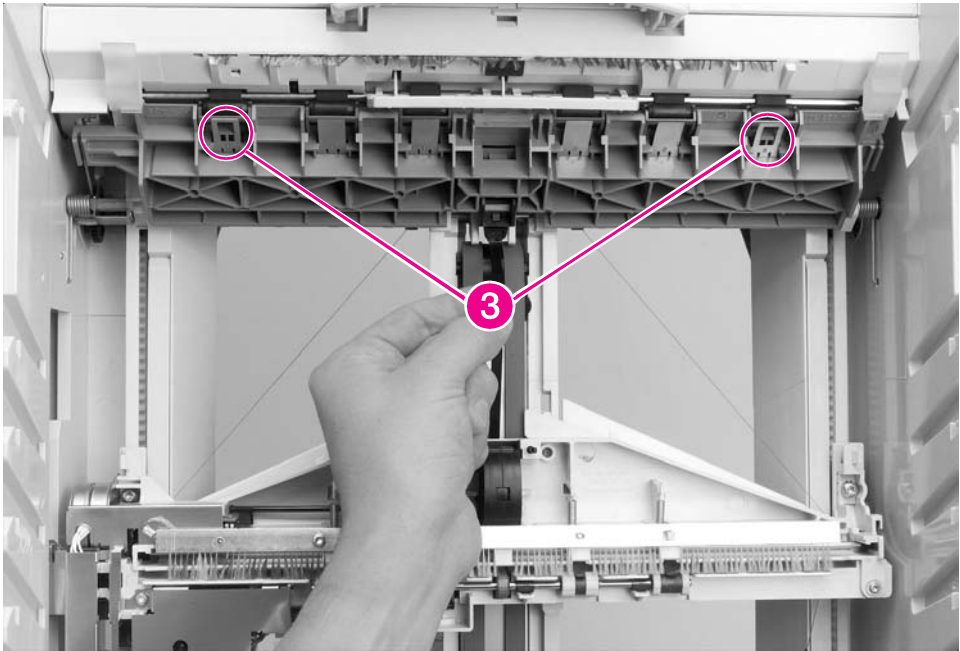

Figure 6-168 8-bin Mailbox Anticurl Strings (2 of 2)

- 5 Release the upper ends of the Anticurl Strings from the Jam Access Door by pushing the retaining tabs that secure the strings to the Jam Access Door (Figure 6-168, callout 3).

To Reinstall:

- 1 Reverse the procedure given above.

Delivery Head Assembly

- 1 Remove the Back Cover from the 8-bin Mailbox (see Figure 6-152).
- 2 Remove all the paper bins and the Blind Cover from the 8-bin Mailbox (see Figure 6-155).

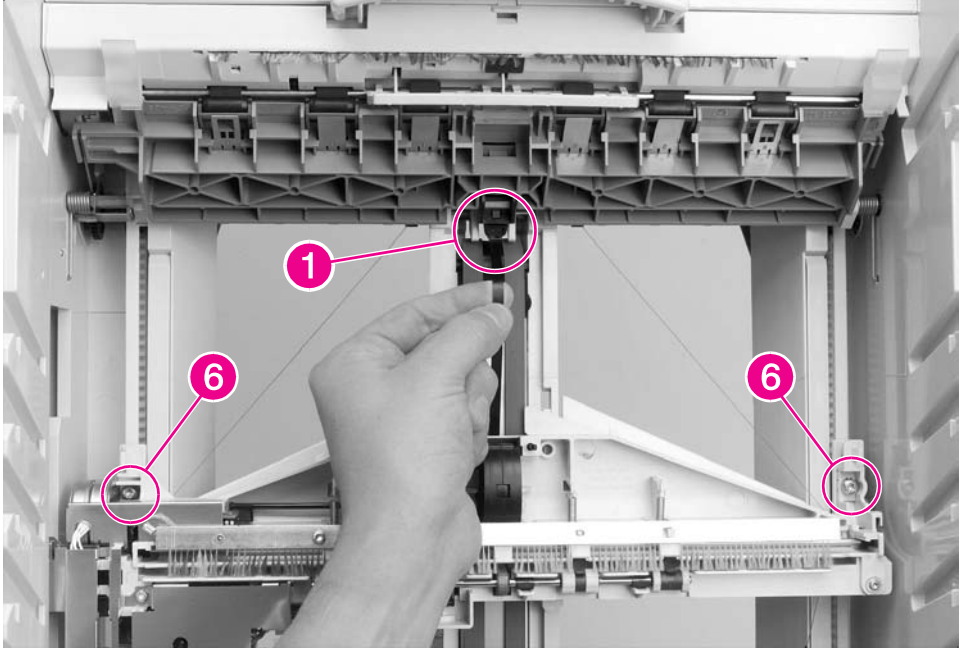

Figure 6-169 8-bin Mailbox Delivery Head Assembly (1 of 4)

WARNING!

The Metal Tape's sharp edges can cause serious injury. When rewinding the Metal Tape into its housing, hold the tape securely and rewind it slowly.

- 3 With the Delivery Head Assembly at the top of the 8-bin Mailbox, hold the Metal Tape near the end, and release the retainer tab that secures the end of the tape to the top of the 8-bin Mailbox frame (Figure 6-169, callout 1). Then let the tape slowly rewind into its housing.

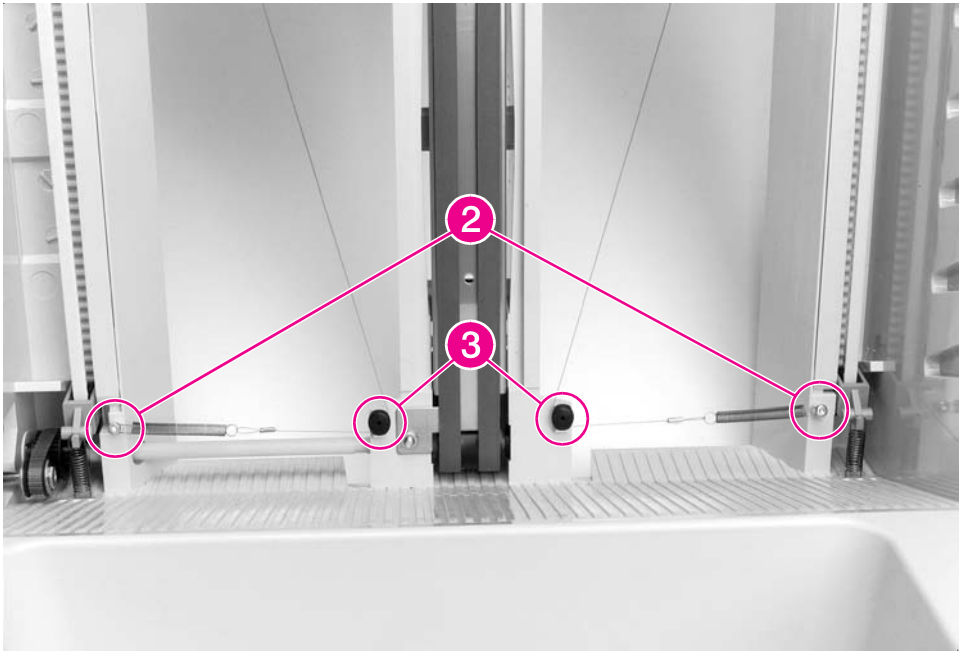

Figure 6-170 8-bin Mailbox Delivery Head Assembly (2 of 4)

- 4 At the lower-left side of the 8-bin Mailbox frame, locate the Tension Springs on the Anticurl Strings, and remove the 2 screws that secure the springs to the frame (Figure 6-170, callout 2).
- 5 Remove the Anticurl Strings from the lower pulleys (callout 3).

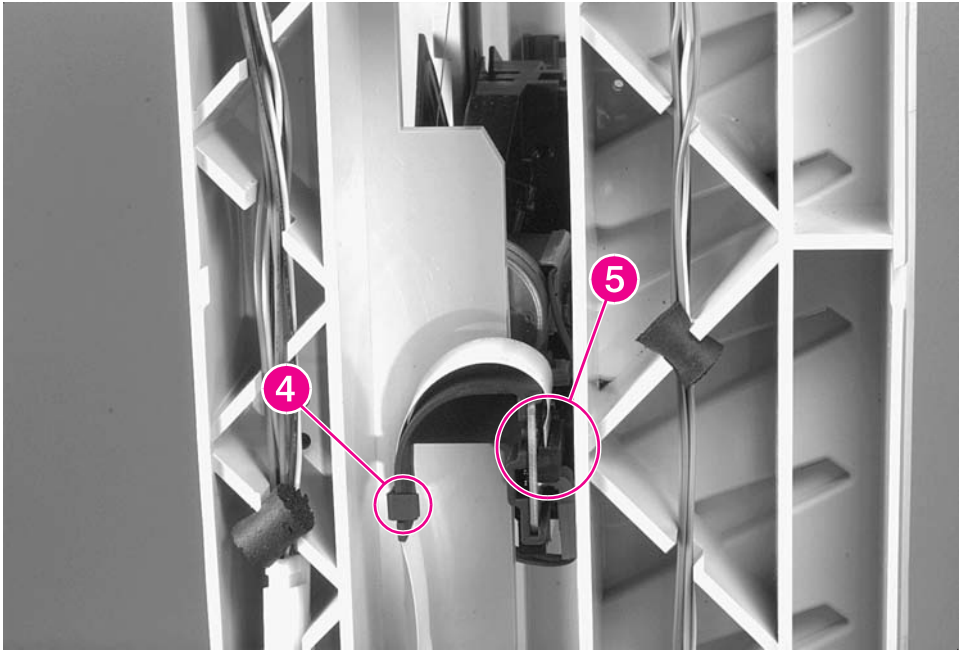

Figure 6-171 8-bin Mailbox Delivery Head Assembly (3 of 4)

- 6 On the back side of the 8-bin Mailbox, release the flat ribbon cable from the cable clip that secures the cable to the 8-bin Mailbox frame (Figure 6-171, callout 4), and gently disconnect the flat ribbon cable from the Delivery Head Assembly (callout 5).
- 7 Raise the Delivery Head Assembly to the top of the 8-bin Mailbox frame.
- 8 Hold up the Delivery Head Assembly, and remove the 2 screws that secure it to the elevator mounts: 1 screw on each end of the assembly (Figure 6-169, callout 6). The screw that secures the back end is captive.

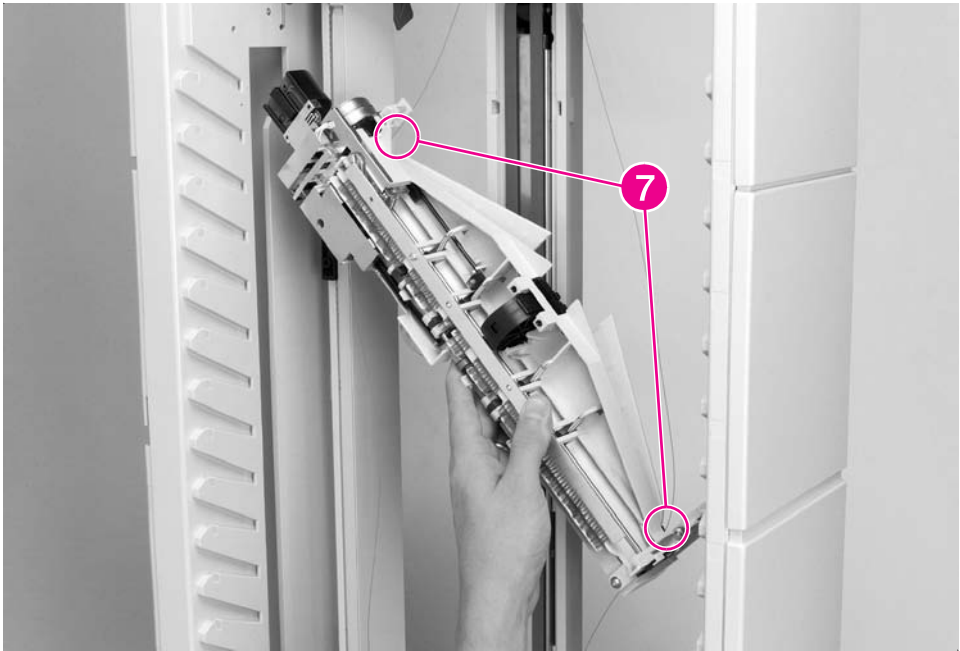

Figure 6-172 8-bin Mailbox Delivery Head Assembly (4 of 4)

- 9** Rotate the Delivery Head Assembly clockwise while guiding the back end out of its access opening (see page 6-172).
- 10** Release the Anticurl Strings from the pulleys on each end of the Delivery Head Assembly (Figure 6-172, callout 7).

To Reinstall:

- 1** Replace the Anticurl Strings into the pulleys on the ends of the Delivery Head Assembly.
- 2** Reinstall the Delivery Head Assembly onto its elevator mounts and secure it with the screws. Make sure that the locating pins are in place.
- 3** Replace the Tension Springs on the Anticurl Strings at the bottom of the frame with the T-10 Torx screws (Figure 6-170, callout 2).
- 4** Snap the Anticurl Strings into the pulleys at the bottom of the frame (Figure 6-170, callout 3).
- 5** Reconnect the flat ribbon cable to the Delivery Head Assembly, and secure the cable to the frame with the cable clip (Figure 6-171, callouts 4 and 5).
- 6** Make sure that the Delivery Head Assembly moves up and down freely.

Interlock Switch

- 1 Remove the Back Cover from the 8-bin Mailbox (see Figure 6-152).

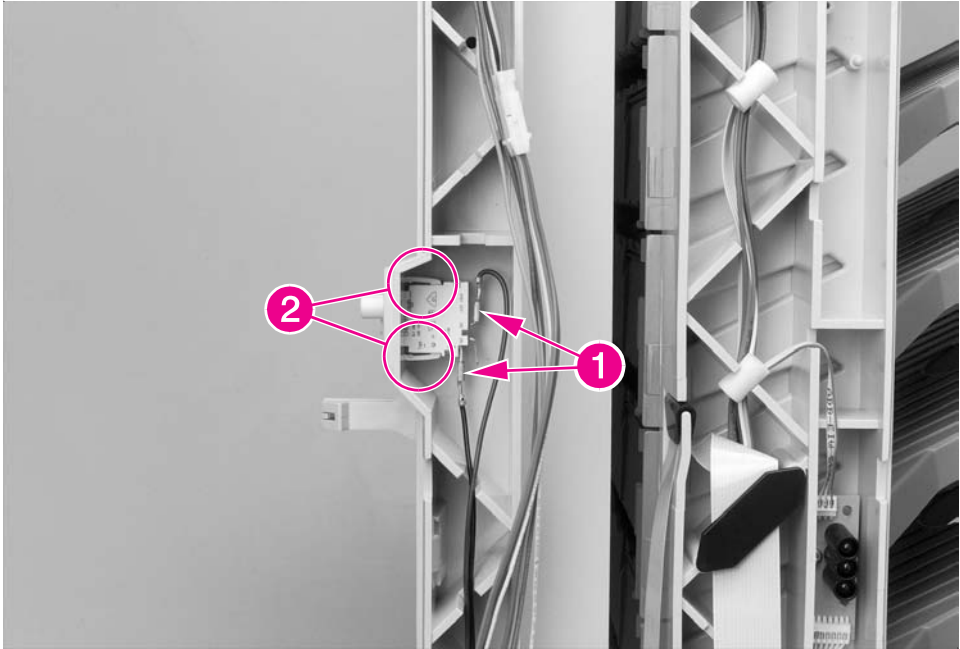

Figure 6-173 8-bin Mailbox Interlock Switch

CAUTION

Before removing the wires from the 8-bin Mailbox Interlock Switch, note the location of each wire. Replacing the wires incorrectly can damage the Interlock Switch.

- 2 Inside the back side of the 8-bin Mailbox frame, disconnect the 2 wires from the Interlock Switch (Figure 6-173, callout 1).
- 3 Remove the Interlock Switch by pressing together the 2 retaining tabs that hold the switch in place (callout 2).

To Reinstall:

- 1 Reconnect the wires in the correct positions (callout 1).

Diagnostic LED PCA

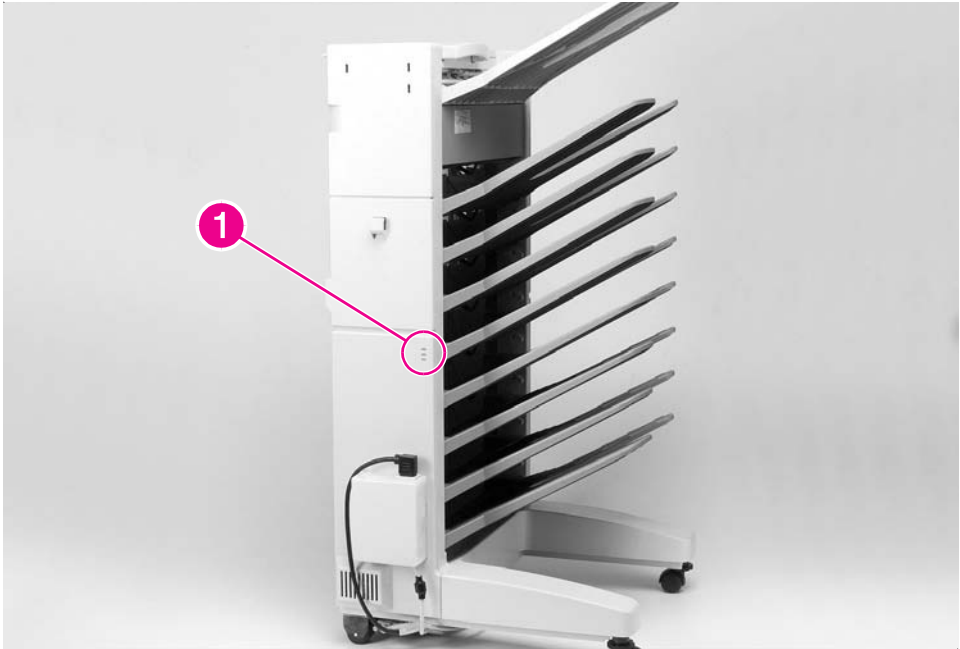

Figure 6-174 8-bin Mailbox Diagnostic LED PCA (1 of 2)

- 1 Locate the Diagnostic LED that is on the back side of the 8-bin Mailbox (Figure 6-174, callout 1).
- 2 Remove the Back Cover from the 8-bin Mailbox (see Figure 6-152).

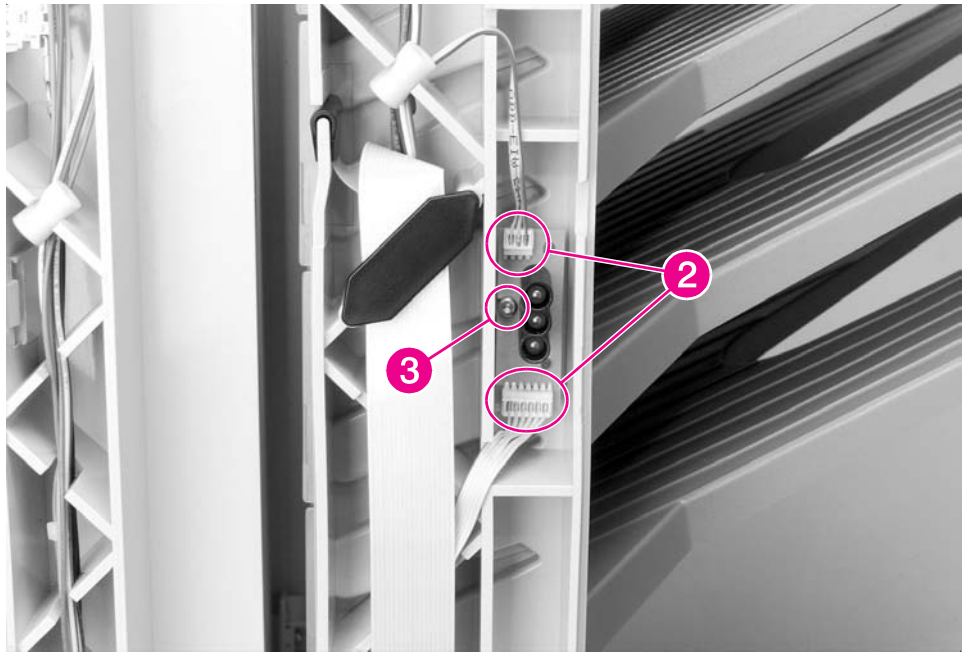

Figure 6-175 8-bin Mailbox Diagnostic LED PCA (2 of 2)

- 3 Disconnect the 2 flat cables from the Diagnostic LED PCA (Figure 6-175, callout 2).
- 4 Remove the 1 screw that secures the Diagnostic LED PCA to the 8-bin Mailbox frame (callout 3).
- 5 Pull the Diagnostic LED PCA away from the 8-bin Mailbox frame.

User Status LED PCA



Figure 6-176 8-bin Mailbox User Status LED PCA (1 of 2)

- 1 Locate the User Status LED PCA that is on the upper-front side of the 8-bin Mailbox (Figure 6-176, callout 1).
- 2 Remove the Front Cover from the 8-bin Mailbox (see Figure 6-152).

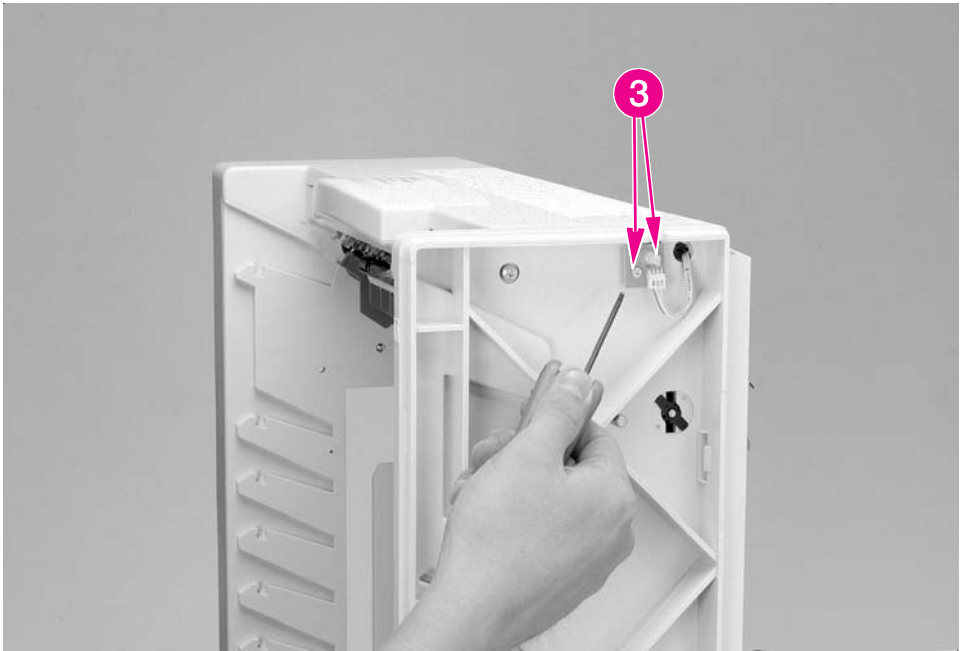

Figure 6-177 8-bin Mailbox User Status LED PCA (2 of 2)

- 3 Disconnect the cable from the User Status LED PCA (Figure 6-177, callout 2).
- 4 Pull the LED PCA away from its frame.
- 5 Remove the 1 screw that secures the LED PCA frame to the 8-bin Mailbox frame (callout 3).

Adjustable and Fixed Casters

Note

The procedures for removing the Adjustable and Fixed Casters are the same.

- 1 Remove the 8-bin Mailbox from the printer.
- 2 Carefully lay the 8-bin Mailbox onto its front side.

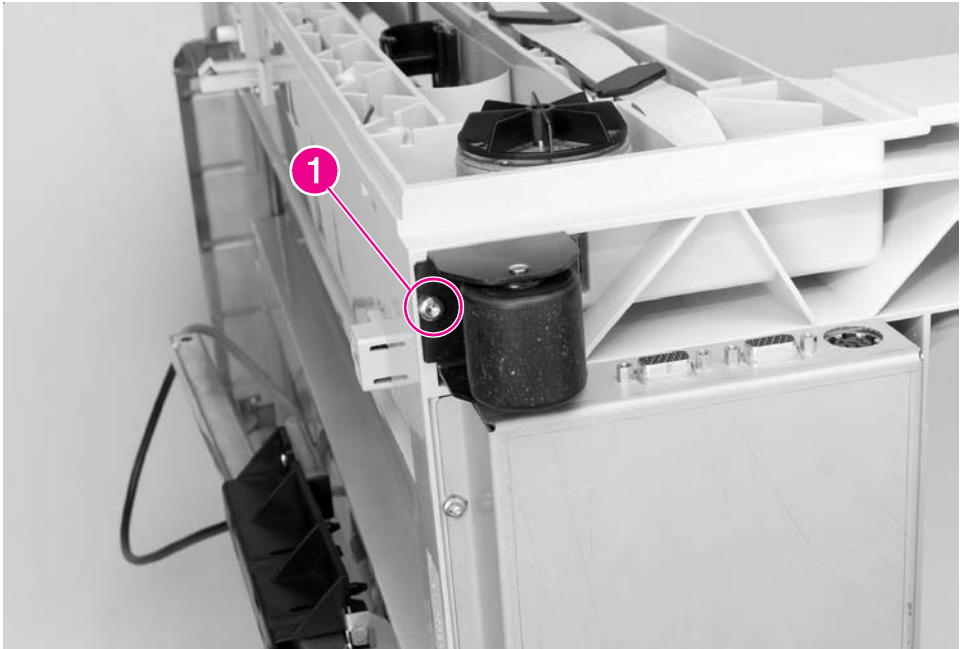

Figure 6-178 8-bin Mailbox Adjustable and Fixed Casters

- 3 Remove the 1 screw that secures the caster to the 8-bin Mailbox frame (Figure 6-178, callout 1).
- 4 Remove the Caster.

Attachment Assembly

- 1 Disconnect the power cable and the C-link cable from the 8-bin Mailbox Controller PCA (see Figure 6-165, callouts 1 and 2).
- 2 Release the Controller PCA from the 8-bin Mailbox frame, but leave the wire cables connected to the Controller PCA (see Figure 6-166).

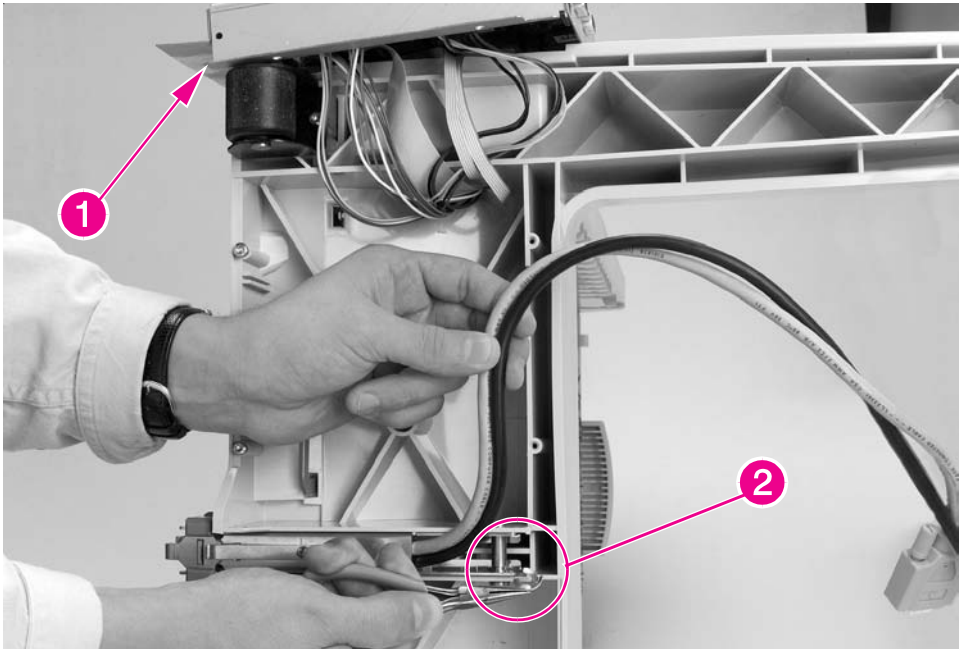

Figure 6-179 8-bin Mailbox Attachment Assembly

- 3 Set the Controller PCA on top of the 8-bin Mailbox unit (Figure 6-179, callout 1).
- 4 Remove the E-clip (callout 2).
- 5 Release the pivot pin that holds the Attachment Assembly's rod to the 8-bin Mailbox frame.
- 6 Remove the attachment assembly.

To Reinstall:

- 1 Replace the E-clip.
- 2 Reconnect the C-link cable and the power cable to the Controller PCA.

Stapler Assembly Removal and Replacement

Note

Reinstallation is generally the reverse of the removal process. Carefully follow any additional instructions provided under "To Reinstall."

Mailbox with Stapler, Stapler Removal or Installation	- - - 417
Back Plate	- - - - - 419
Stapler Controller PCA	- - - - - 421
Top Cover Assembly	- - - - - 424
Stapler Bed Assembly	- - - - - 425
Hinges	- - - - - 427

Mailbox with Stapler, Stapler Removal or Installation



Figure 6-180 Mailbox with Stapler, Stapler Removal or Installation

The Stapler Assembly is mounted in the 5-bin Mailbox with Stapler, replacing the three Face-down bins and the blind cover.

- 1 Turn off the printer.
- 2 Make sure the Delivery Head Assembly is not in the stapler area. It should be in the bottom portion of the mailbox. You can move the Delivery Head Assembly downward gently with your hand.

- 3 Disconnect the C-link cable connecting the mailbox to the stapler. See figure 6-181.

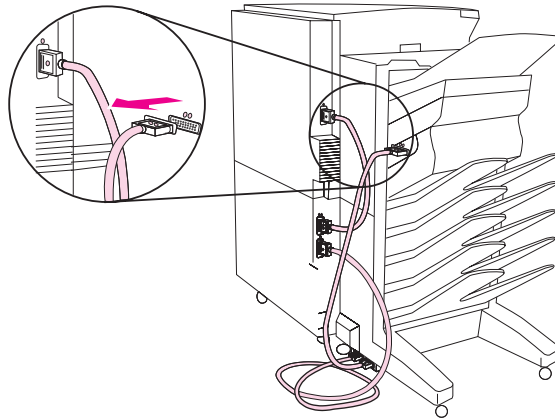

Figure 6-181 C-link Cable on Mailbox with Stapler

- 4 Remove the Face-up Bin (figure 1-2 on page 5). Lift the bin gently to remove it.
- 5 Lift up on the outer edge of the stapler to clear the retaining notches, and pull the stapler forward out of the frame (figure 6-180).

To Reinstall:

- 1 Slide the stapler into the 4th slot from the top, and lower it into its retaining notches (figure 6-180).
- 2 Replace the Face-up Bin.
- 3 Connect the C-link cable from the mailbox to the stapler. Turn the printer on.

Back Plate

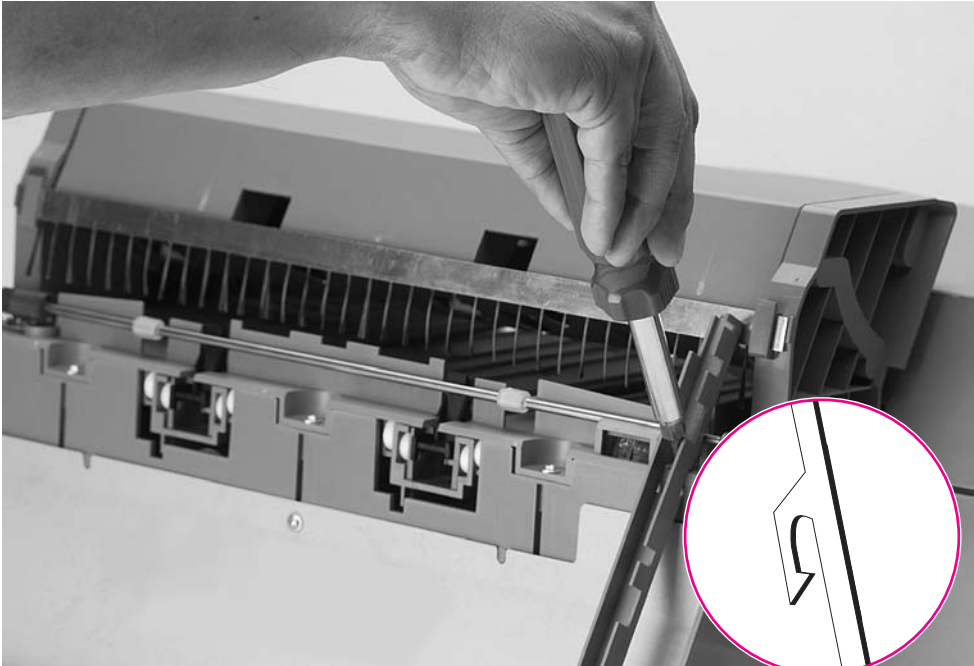

Figure 6-182 Back Plate (1 of 2)

- 1 Remove the Stapler Assembly (see figure 6-180).
- 2 Remove the Scan Bar by carefully pressing the tab on the scan bar backwards and downwards through the hole of the Stapler Bed (see figure 6-182) with a flat-tip screwdriver, then lift the bar.

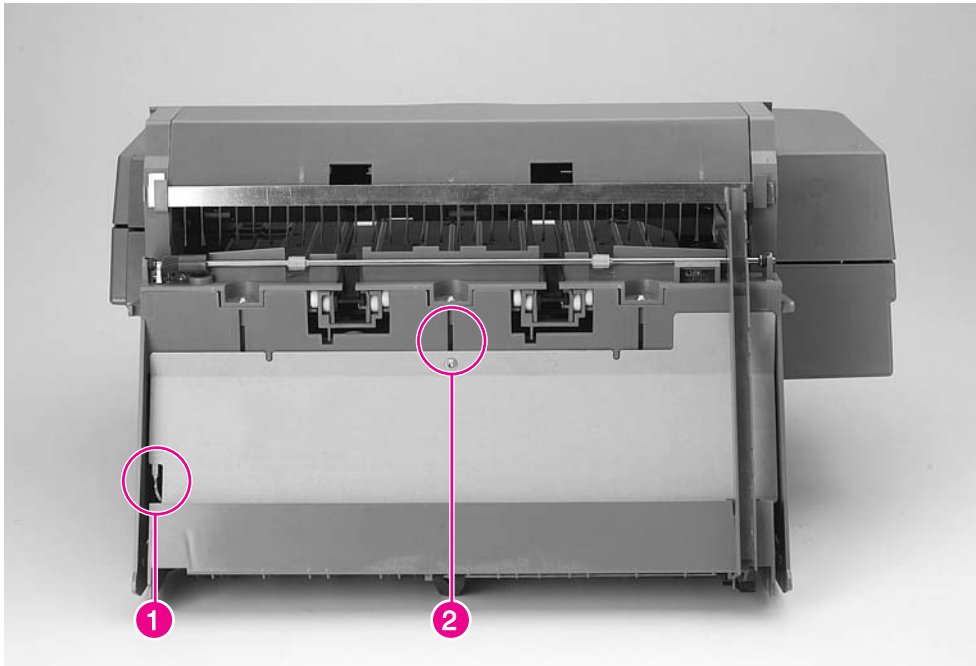

Figure 6-183 Back Plate (2 of 2)

- 3 Remove the Torx screw joining the Back Plate with the Stapler (see figure 6-183, callout 2).
- 4 Release the ground cable that is connected to the Back Plate (see figure 6-183, callout 1).

To Reinstall:

CAUTION

Do not overtighten the screws when replacing the Back Plate.
Do not touch the metallic plate edges.

Stapler Controller PCA

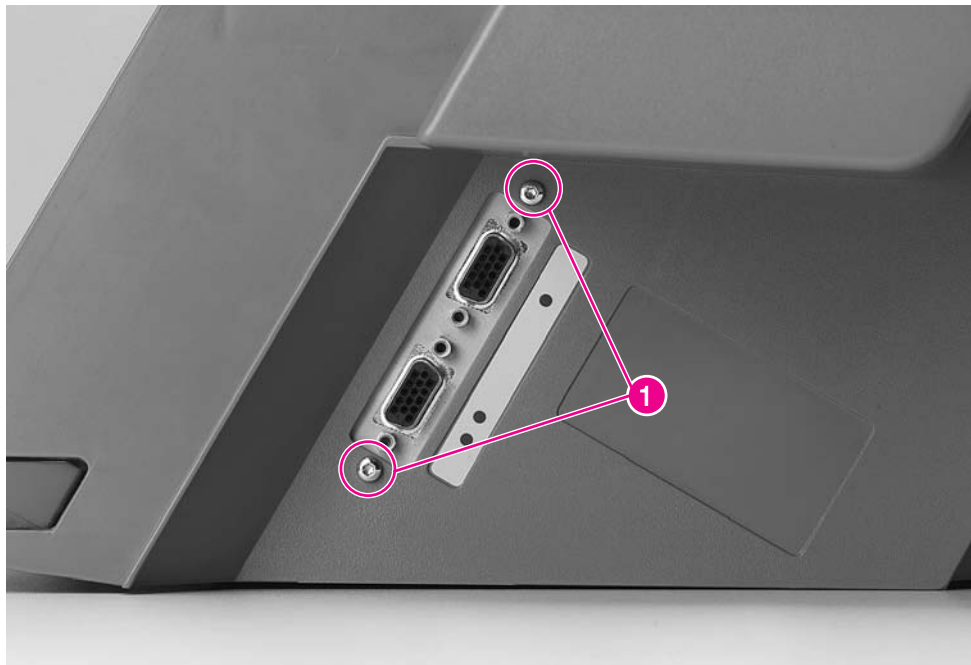

Figure 6-184 Stapler Controller PCA (1 of 3)

- 1 Remove the Stapler Assembly (see figure 6-180).
- 2 Remove the Back Plate (see figure 6-182).
- 3 Remove 2 screws located on the right side of the Stapler (see figure 6-184, callout 1).

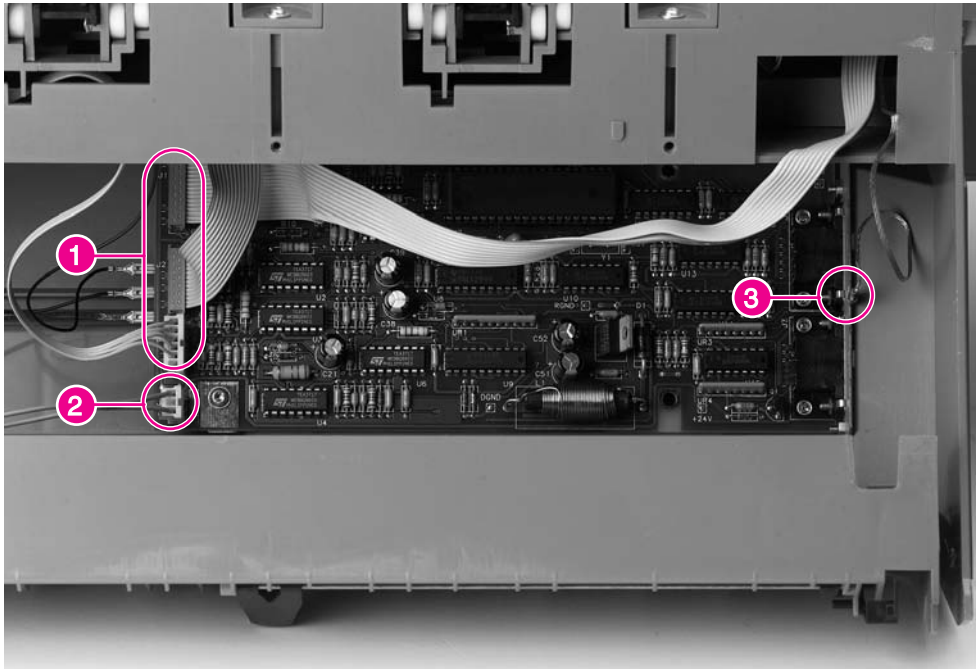

Figure 6-185 Stapler Controller PCA (2 of 3)

- 4 Unplug the cables that are connected to the PCA. Identify their color and size and the ground cables (see figure 6-185, callouts 1 and 2).

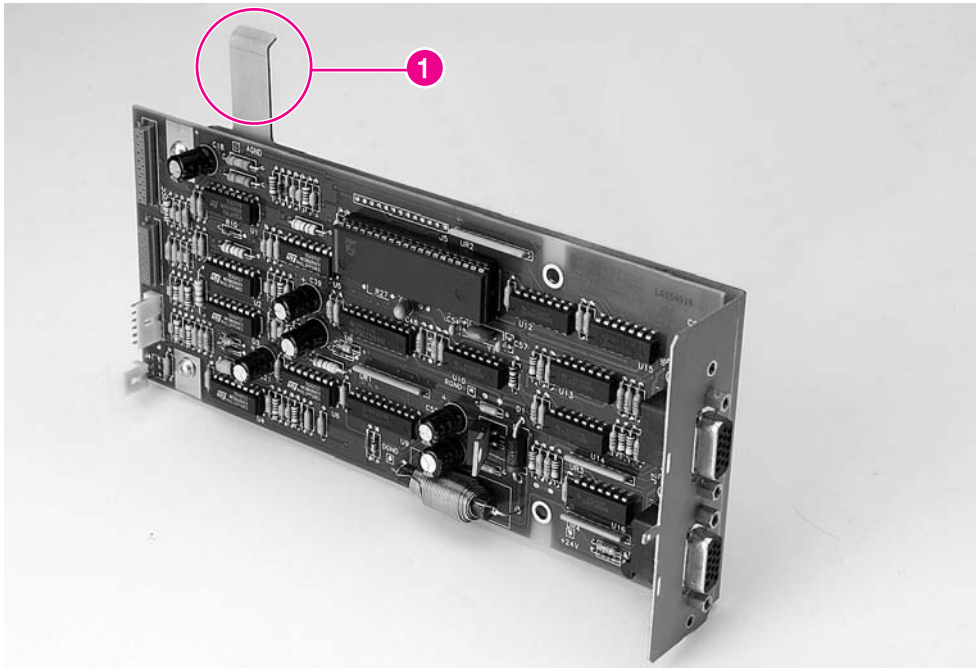

Figure 6-186 Stapler Controller PCA (3 of 3)

- 5 The board is supported by a hooked tab at the top of the card (see figure 6-186, callout 1). Slide the board to the left and then down.

To Reinstall:

- 1 Slide the board up and then to the right.
- 2 Reconnect all cables.

Top Cover Assembly



Figure 6-187 Top Cover Assembly

- 1 Remove the Stapler Assembly (see figure 6-180 on page 417).
- 2 Open the Top Cover Assembly, and remove the Back Plate (see figure 6-182 on page 419).
- 3 Unplug the ground and signal cables from the right side of the Stapler Controller board, being careful to keep them in the cable holder. See callout 1 and 3 on figure 6-185.
- 4 On each side of the assembly, pull the hinge to release the 2 posts from the retaining notches (see figure 6-187).

To Reinstall:

CAUTION

Keep the Top Cover Assembly open while reconnecting the cables. Cable damage could occur the next time the cover is opened if the cables are reinstalled too tightly.

Stapler Bed Assembly

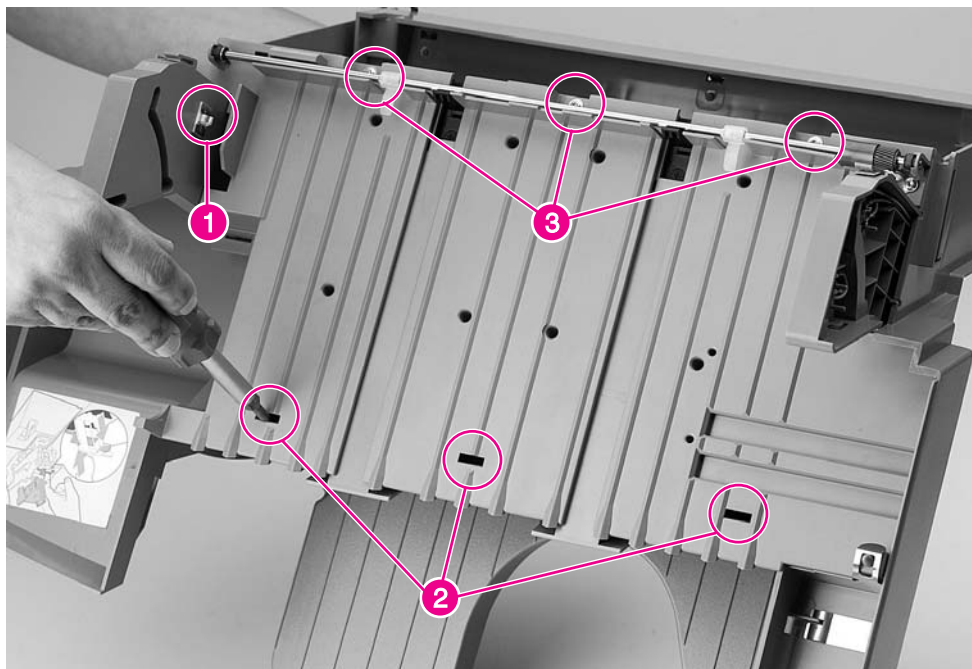

Figure 6-188 Stapler Bed Assembly

- 1 Remove the Stapler Assembly (see figure 6-180 on page 417).
- 2 Remove the Back Plate (see figure 6-182 on page 419).
- 3 Remove the Stapler Unit Controller PCA (see figure 6-188 on page 425, callout 1).
- 4 Remove the Top Cover Assembly (see figure 6-187 on page 424).
- 5 Remove the wire frame by pushing both arms of the wire frame toward the center to clear the retaining notches and lift.
- 6 Release the brushes bar from the retaining notches and lifting upwards.
- 7 Insert a flat-blade screwdriver into the top of the Stapler Bed Assembly and push gently to release the latches in the front of the stapler bed (see figure 6-188 on page 425, callout 2).
- 8 Remove 3 Torx screws that join the stapler bed with the rest of the unit (see figure 6-188 on page 425, callout 3).
- 9 To remove the Stapler Bed Assembly, lift the edge of the assembly where the stapler unit resides, then gently lift the entire Stapler Assembly.

To Reinstall:

Replace the Stapler Bed. Replace the Stapler Controller. Replace the actuator for the paper bin empty sensor.

CAUTION

Make sure that the actuator is oriented as shown in its proper place before replacing the Stapler Bed Assembly (see figure 6-189 on page 427, callout 3).

Hinges

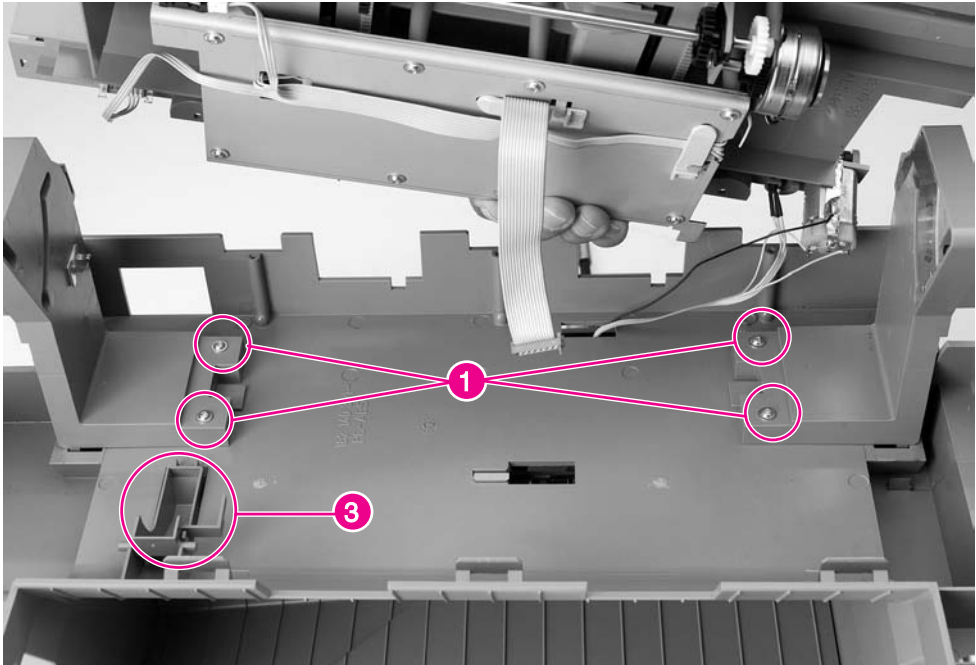

Figure 6-189 Hinges

- 1 Remove the Stapler Assembly (see figure 6-180 on page 417).
- 2 Remove the Top Cover Assembly (see figure 6-187 on page 424).
- 3 Remove the Stapler Bed Assembly (see figure 6-188 on page 425).
- 4 Release the brushes bar from the retaining notches, and lift upwards.
- 5 Remove 2 screws joining each hinge to the housing (see figure 6-189, callout 1).
- 6 Disconnect the 2 cables in the hinge containing cables from the Stapler Controller PCA (see figure 6-185 on page 422, callout 2).

HP Digital Copy 320 Removal and Replacement

WARNING!

Make sure the power is off and the main power to the system has been disconnected before servicing.

Note

Unplug the HP Digital Copy 320, separate it from its stand, and place it on a table to perform removal and replacement procedures.

Installing the HP Digital Copy 320- - - - -	430
Hardware Table- - - - -	437
Orientation of the HP Digital Copy 320 - - - - -	439
Copy Module Maintenance Parts - - - - -	440
Copy Module Skins- - - - -	445
Copy Module Power Supply/Main Board Assemblies - - -	464
Copy Module ADF Unit Assemblies - - - - -	475
Copy Module Flatbed Assemblies- - - - -	488

For required tools, see page 203.

Installing the HP Digital Copy 320

1

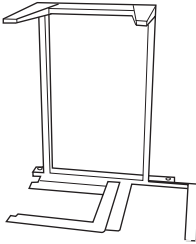

Install the HP Digital Copy 320 on the Optional HP Digital Copy 320 Stand

For detailed instructions on setting up the HP Digital Copy 320 Stand, see the installation guide that came with the stand.

- 1 Place the HP Digital Copy 320 Stand near the desired location.

Note

Be sure to leave space for the installation of the accessories. See “Space Requirements” on page 47 for dimensions.

It is also important to leave space between the stand and the desired location to allow access to the cables during installation.

WARNING!

Use caution when completing the following steps. Once you place the HP Digital Copy 320 on the stand, bumping or moving may cause it to tip. The Mopier must be moved into position immediately after installation of the HP Digital Copy 320 is complete.

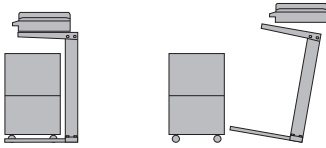

2

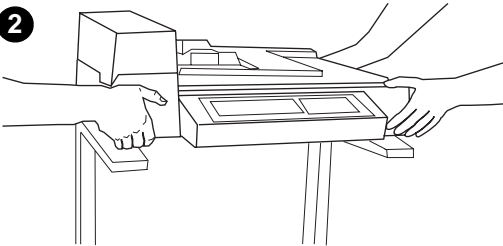

3

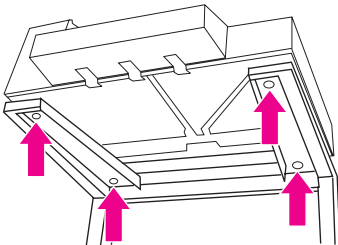

- 2 With one other person, lift the HP Digital Copy 320 and align it with the screws on the HP Digital Copy 320 Stand.
- 3 With a flathead screwdriver, screw the HP Digital Copy 320 onto the stand.

4

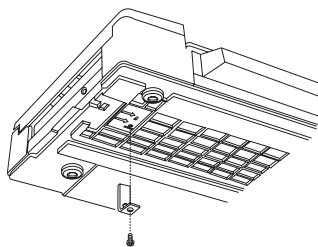

5

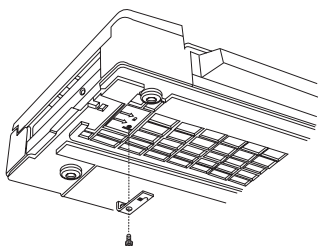

6

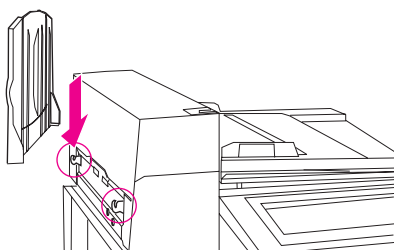

7

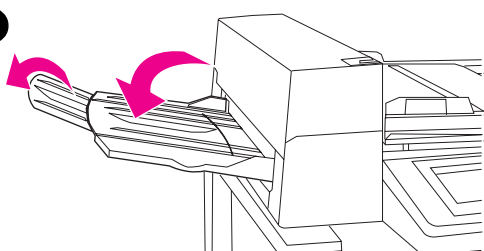

8

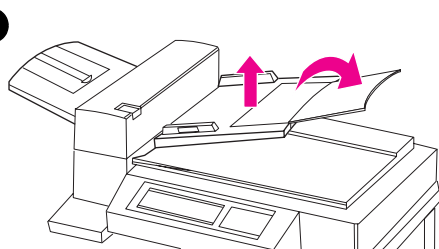

CAUTION

Operating the HP Digital Copy 320 with the shipping lock in place might damage the device. It is important that you perform steps 4 and 5.

- 4 Unscrew and remove the shipping lock.
 - 5 Rotate the shipping lock and reinsert it into the HP Digital Copy 320 in the unlocked position.
-

Note

When you replace the shipping lock, you may need to power cycle the Mopier to move the Carrier Unit into position.

- 6 To install the output bin, hold the bin vertically (as shown) and push down to attach the bin to the metal guides.
- 7 Pull the output bin down. For longer paper, flip the bin extension out as shown.
- 8 Lift the input tray up to lock it into place. For longer paper, flip the tray extension out as shown.

Install the Mopier on the Optional Input Accessory

For detailed instructions on installing the Mopier onto the optional input accessory, see the installation guide that comes with the accessory.

Roll the Mopier onto the Optional HP Digital Copy 320 Stand

- 1 Lift both sides of the Mopier and gently rock the Mopier back and forth as you push it onto the stand.
- 2 When the Mopier is in place, lock the wheels and rotate the levelers up or down to stabilize the Mopier.

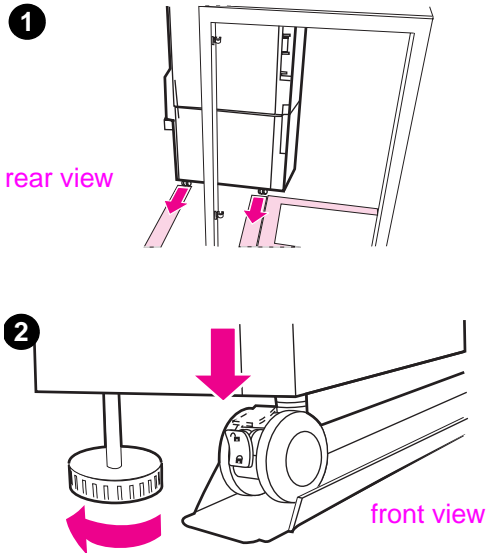

Install the Optional Output Accessory

Note

For detailed information on installing the optional output accessory, see the installation guide that came with the accessory and the online Mopier user guide that came with the Mopier.

- 1 Roll the optional output accessory onto the HP Digital Copy 320 Stand.

Note

Be sure to properly align the mounting bracket as you roll the optional output accessory onto the HP Digital Copy 320 Stand.

- 2 After the front two rollers are on the base of the HP Digital Copy 320 Stand, attach the mounting bracket (called out below).
- 3 Roll the optional output accessory toward the Mopier until it clicks into place.

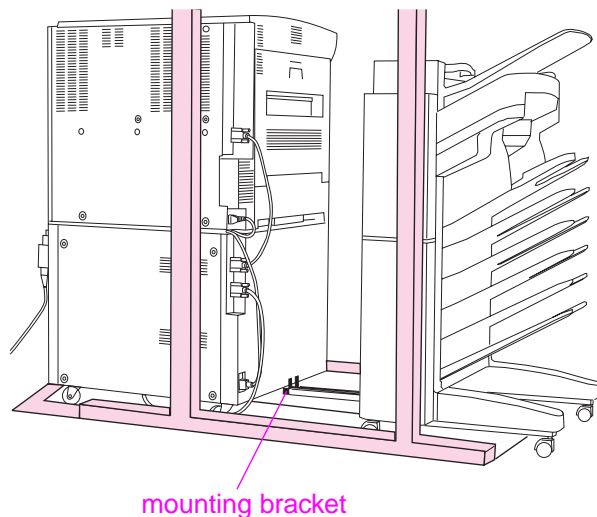

Figure 6-190 Optional Output Accessory

Note

Be sure to leave enough space to completely extend the optional output accessory away from the Mopier. See “Space Requirements” on page 47.

For cabling information, see “Communication Link (Daisy Chain)” on page 180.

Install the Copy Connect EIO Board into the Mopier

CAUTION

Make sure that the Mopier is turned off.

Insert the Copy Connect EIO Board that came with the HP Digital Copy 320 into slot 3 (the top slot) on the Mopier. (Use the screws that are in the existing EIO cover to install the Copy Connect EIO Board.)

Note

If a cover is on slot 3, use a phillips screwdriver to remove the two screws. Remove the cover and install the Copy Connect EIO Board.

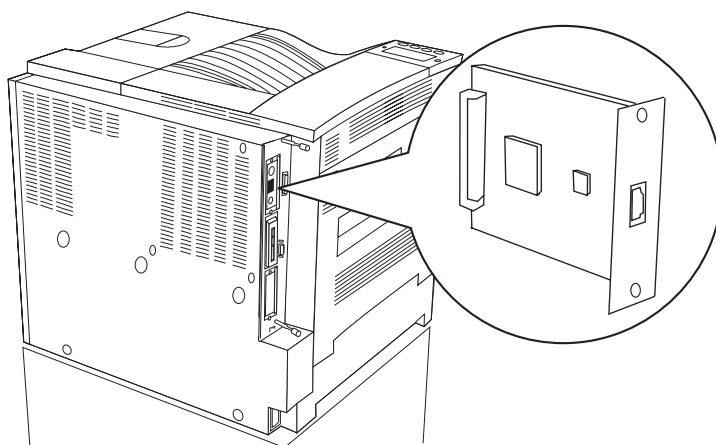

Figure 6-191 Copy Connect EIO Board (slot 3)

Install the Copy Connect Cable

- 1 Plug the Copy Connect cable into the HP Digital Copy 320 (A).

Note

See the icon on the back of the HP Digital Copy 320 for correct orientation of the cable.

- 2 Plug the other end of the Copy Connect cable into the Copy Connect EIO Board (B).
- 3 Wrap the excess cable as shown in figure 6-192(C).

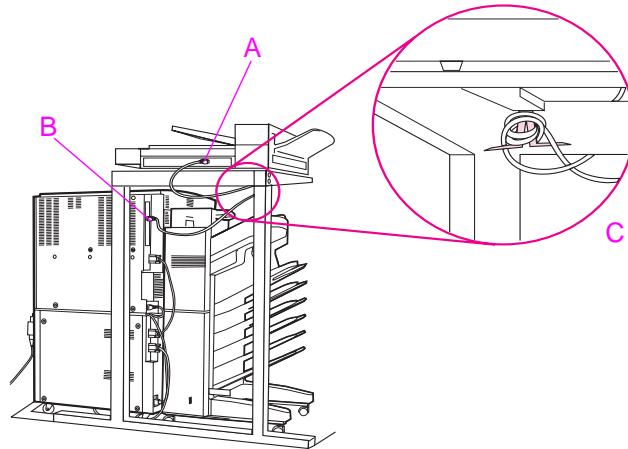

Figure 6-192 View with HP Digital Copy 320 Stand (preferred configuration)

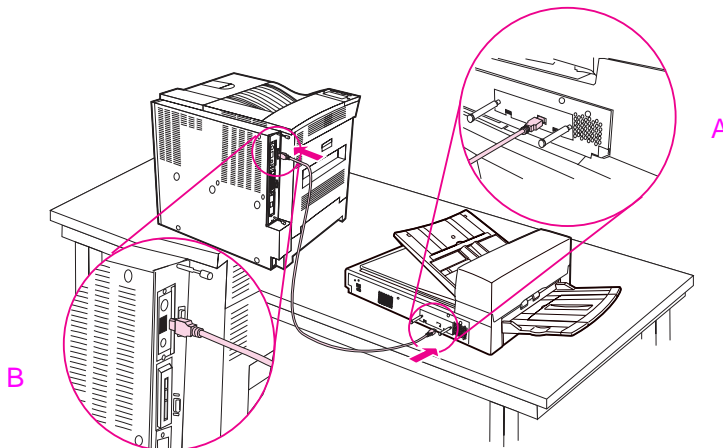
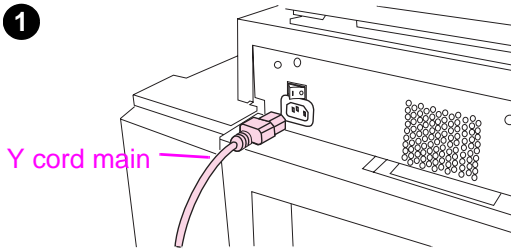

Figure 6-193 View with HP Digital Copy 320 on Tabletop

1



Install the Y Power Cord

CAUTION

Turn off the Mopier and HP Digital Copy 320 before you install the Y power cord.

2

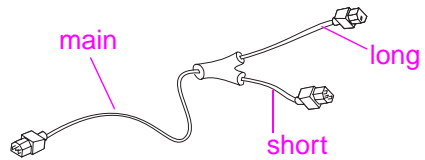
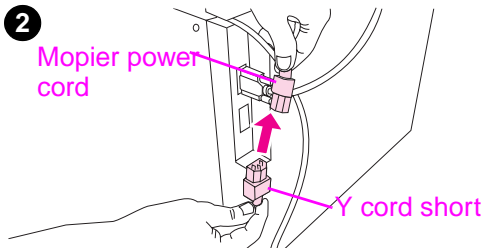

3

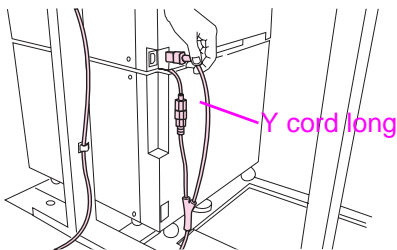

- 1 Plug the main end of the Y power cord into the HP Digital Copy 320.
- 2 Unplug the power cord from the Mopier. Plug the power cord into the short end of the Y power cord.
- 3 Plug the long end of the Y power cord into the Mopier.

Hardware Table

Note

The numbers in the “Reference” column are used in the diagrams in Chapter 8.

Table 6-2. Hardware Table

Example	Reference	Description	Part Number (for kits of 20)
	B1	TP Screw m3 x 8	PA03002-C282FJ
	B2	TP Screw m3 x 6	PA03002-C281FJ
	B3	TP Screw m4 x 8	PA03002-C288FJ
	B4	Machine Screw w/washer m3 x 6	PA03002-C283FJ
	B5	Machine Screw w/washer m3 x 8	PA03002-C284FJ
	B6	Machine Screw w/washer m3 x 35	PA03002-C285FJ

Table 6-2. Hardware Table (continued)

Example	Reference	Description	Part Number (for kits of 20)
	B10	Machine Screw w/washer m4 x 8	PA03002-C286FJ
	B15	Flathead Screw m3 x6	PA03002-C287FJ
	B20	E-ring, Latch Lever (20pcs)	PA03002-C254FJ
	B21	E-ring, Idle Roller (20pcs)	PA03002-C253FJ
	B22	Retainer Ring ADF Lock Bearing (20pcs)	PA03002-C255FJ
		Thumb Screw for Document Cover	PA03002-C290FJ
		Thumb screws for Pick Roller Cover	PA03002-C123FJ

NEED EXAMPLES OF SCREWS

Orientation of the HP Digital Copy 320

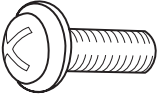
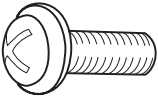
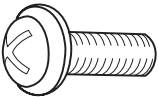
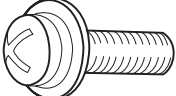
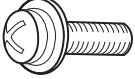
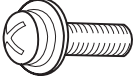
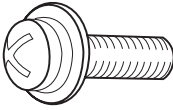
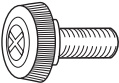
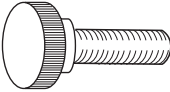
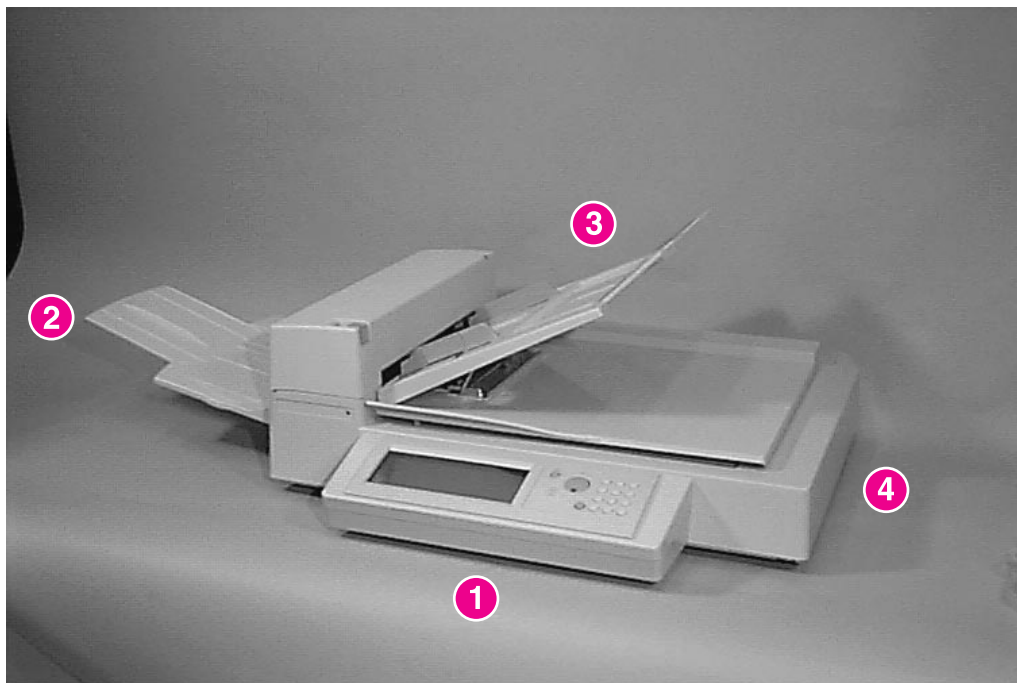

Figure 6-194 Orientation of the HP Digital Copy 320

- 1 Front
- 2 Left
- 3 Back
- 4 Right

WARNING!

Remove the power cord before you begin service procedures.

Copy Module Maintenance Parts

Separation Pad Assembly

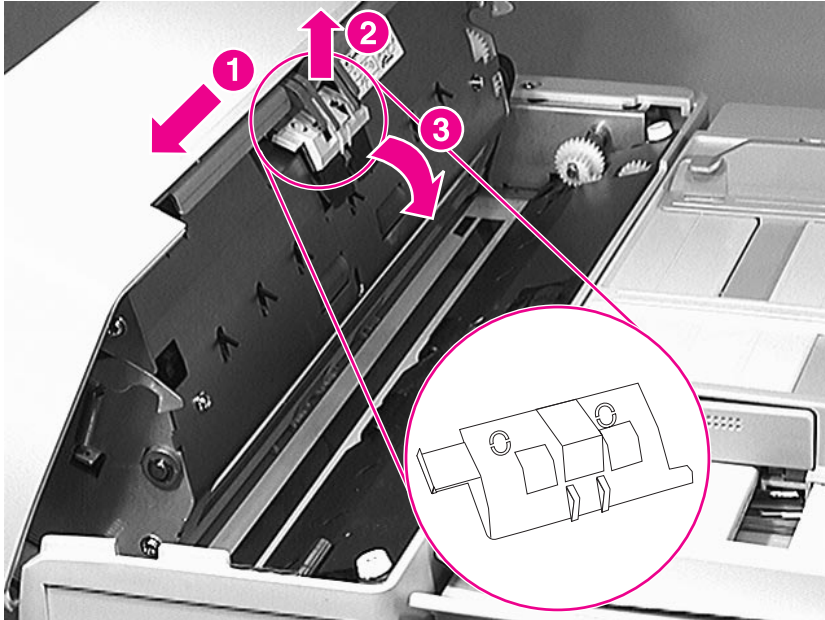

Figure 6-195 Separation Pad Assembly

CAUTION

Do not bend the pick spring (metal tabs) as you remove the Separation Pad Assembly.

- 1 Open the ADF.
- 2 Push the Separation Pad Assembly in the direction of the imprinted arrow (callout 1).
- 3 Rotate the Assembly down, free of the pick spring (callout 3).

To replace

Reverse the above procedure.

Pick Roller Assembly

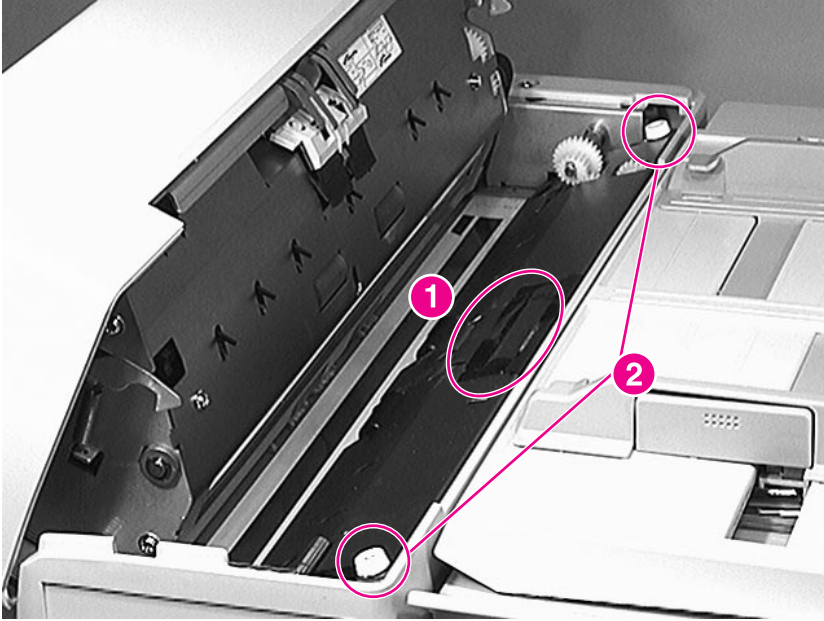

Figure 6-196 Pick Roller Cover

CAUTION

As you remove the Pick Roller Cover, do not bend the plastic parts in the middle of the cover (callout 1).

- 1 Remove 2 Flathead M3x6 thumb screws (callout 2) and remove the Pick Roller Cover.

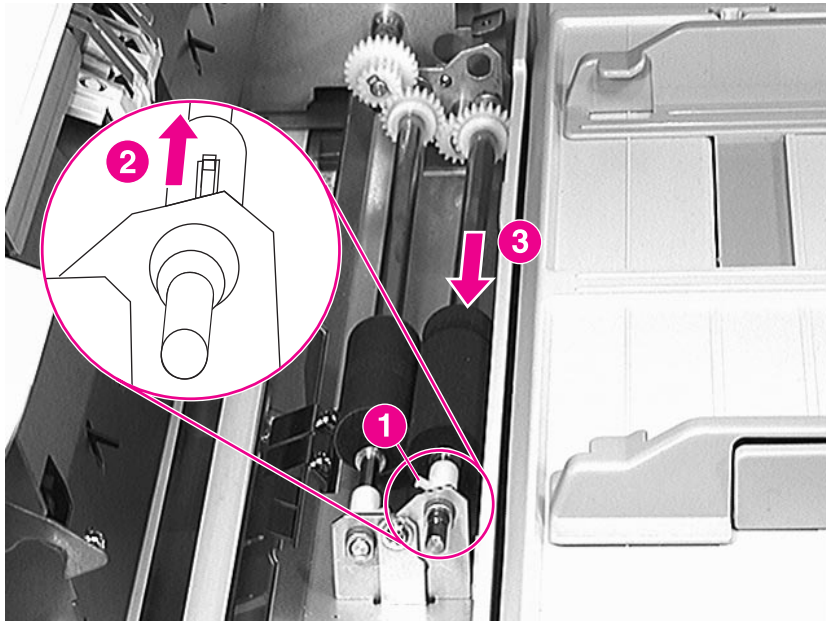

Figure 6-197 Pick Rollers (1 of 2)

- 2** Lift the white tab (callout 1) and push the collar toward the black roller (callout 2). This allows the brass bushing to slide along the shaft.
- 3** Slide the whole shaft and roller forward to release the shaft from the hole in the rear (callout 3).

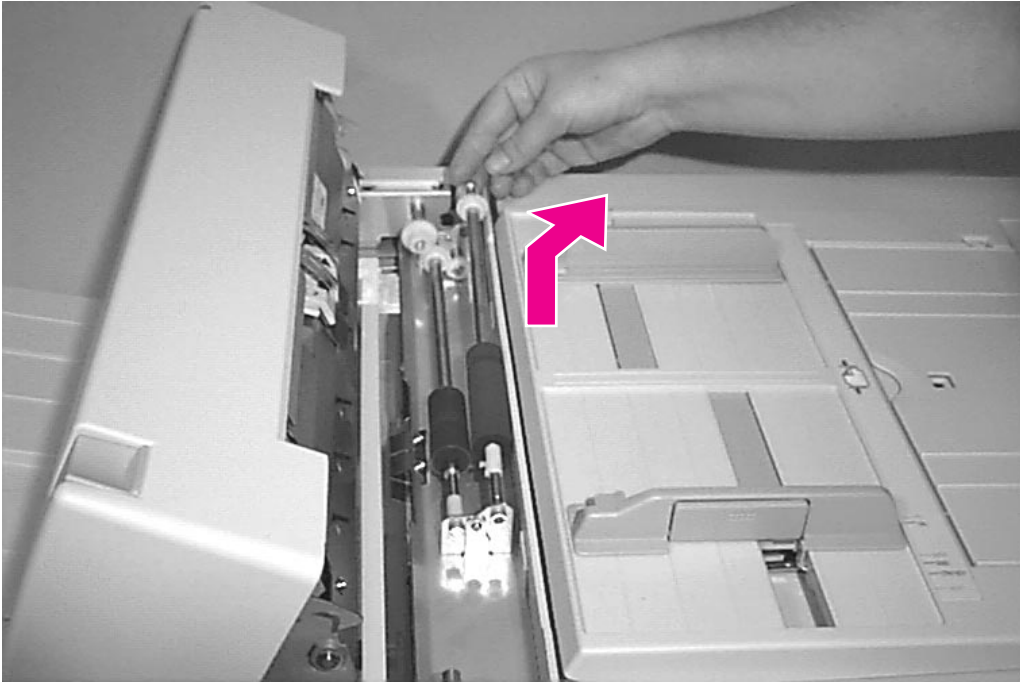

Figure 6-198 Pick Rollers (2 of 2)

- 4 Lift out the rear end of the roller and release the shaft from the hole in the front. Lift out the entire roller and shaft assembly.

CAUTION

Do not touch the rubber part of the new rollers. Skin oils or gear lubricant can damage the rollers.

Note

Important! Retain the brass bushings. Replacement Pick Rollers include the white collar but not the bushings.

When you replace the brass bushings on the roller, note that they are keyed flat on the sides to fit correctly in the holes.

- 5 Remove the front and rear brass bushings if they are not worn and place them on the new roller.

Note

To remove the second roller, follow the steps above. Note the difference between the rollers to replace the correct roller in its place.

To replace

- 1 Reverse the above procedure.

CAUTION

Do not touch the rubber part of the new rollers. Skin oils or gear lubricant can damage the rollers.

- 2 Place the brass bushings on the new roller and replace the front end first.
- 3 Align the rear end of the Pick Roller Cover with the gears first and then replace the cover.

Copy Module Skins

Document Holding Pad

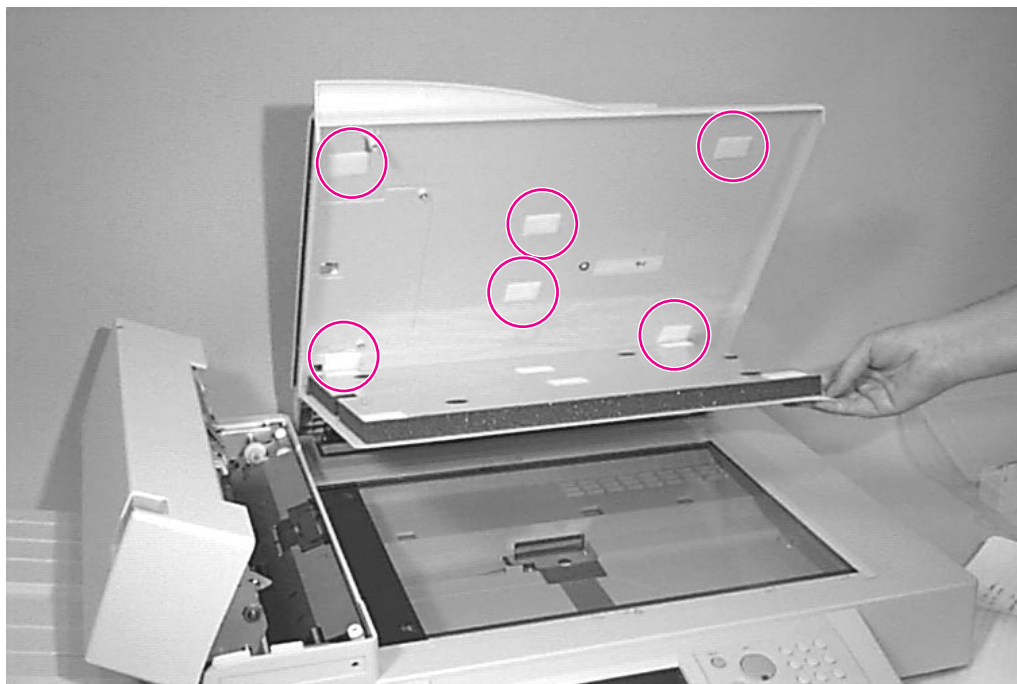

Figure 6-199 Document Holding Pad

Pull apart the Velcro pads and remove the Document Holding Pad.

Paper Chute Flip-out

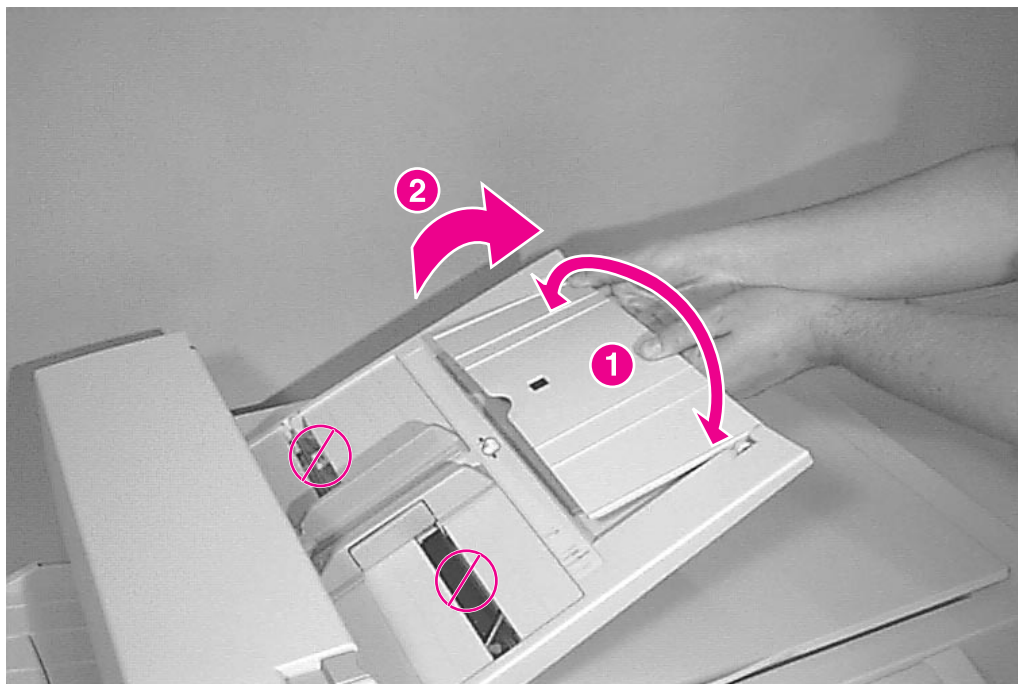

Figure 6-200 Paper Chute Flip-out

CAUTION

Do not attempt to remove the screws that hold the paper chute onto the FB Cover Assembly. If the screws are removed, the chute cannot be realigned properly by field service personnel.

- 1 Bow the tray slightly to free the pins from the hinges (callout 1).
- 2 Lift the tray out of the slots (callout 2).

Output Tray Flip-out

- 1 Bow the tray slightly to free the pins from the hinges.
- 2 Lift the tray out of the slots.

Note

This procedure is not shown because it is similar to removing the Paper Chute Flip-out (above).

Output Tray

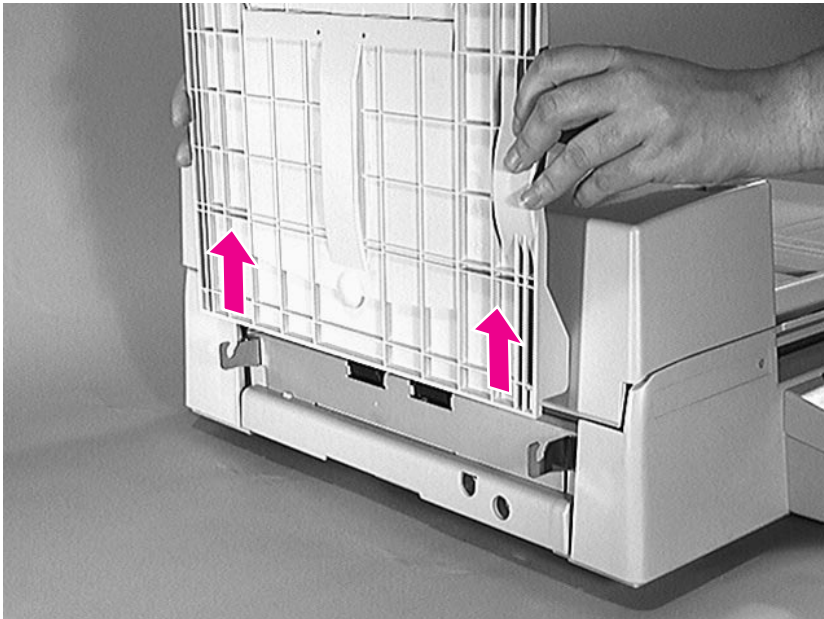

Figure 6-201 Output Tray

- 1 To remove the Output Tray, close the Output Tray Flip-out and raise the tray to the vertical position.
- 2 Lift the tray straight up.

Flatbed (FB) Cover Assembly

CAUTION

Do not attempt to remove the screws that hold the paper chute onto the FB Cover Assembly. If the screws are removed, the chute cannot be realigned properly.

The Rubber Stop, Paper Chute Flip-out, and Document Holding Pad can be replaced. Do not remove any other parts of the FB Cover Assembly.

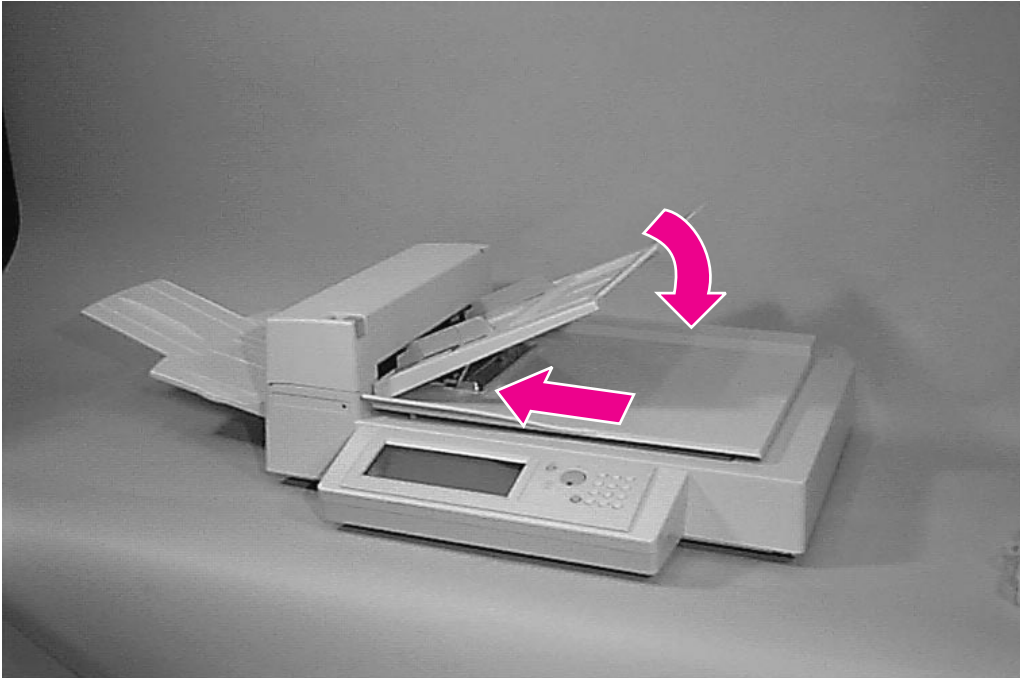

Figure 6-202 FB Cover Assembly

- 1 Push in the metal support and lower the chute to the storage position. Open the cover.

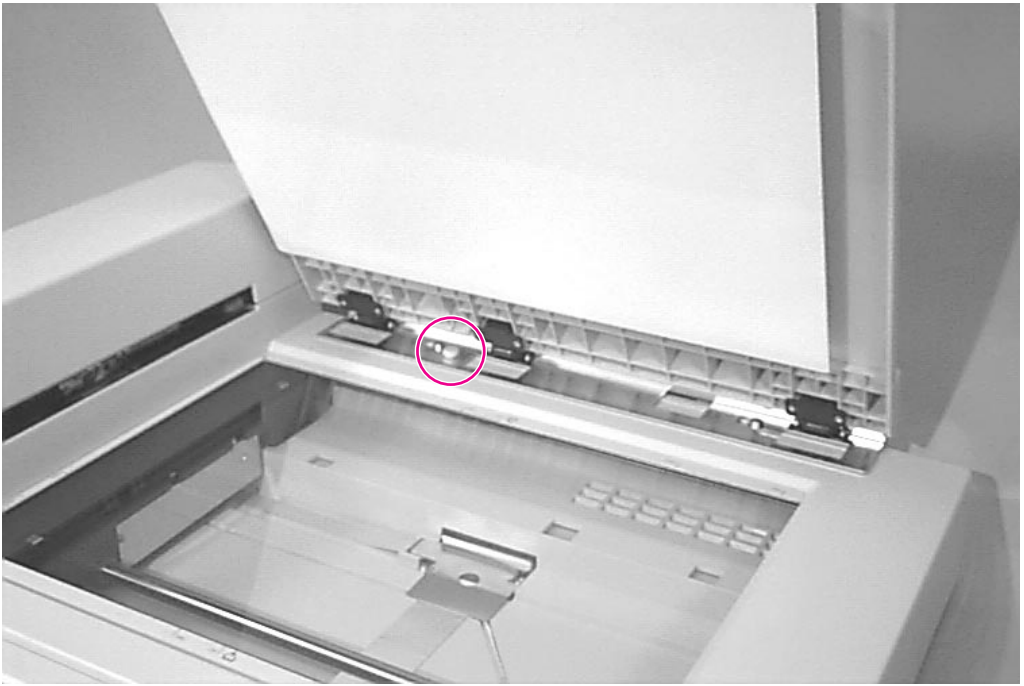

Figure 6-203 Thumb Screw for Document Cover Assembly

- 2 Remove the thumb screw.

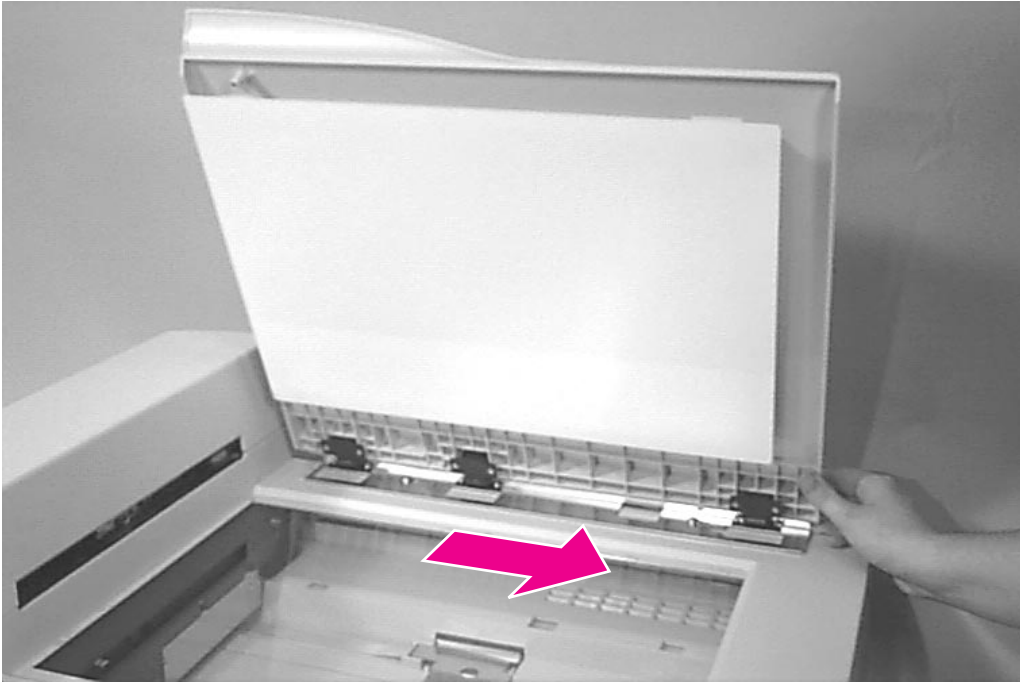

Figure 6-204 Removing the Cover from the Posts

CAUTION Do not hit the glass as you remove the FB Cover Assembly.

- 3 The FB Cover Assembly rests on two posts. Slide the assembly to the right to release it, then lift it straight up.

ADF Latch Cap



Figure 6-205 ADF Latch Cap

CAUTION

A magnetic screwdriver is required to remove the ADF Latch Cap.

- 1 Open the ADF.
- 2 Locate the screw inside the ADF Latch Cap.
- 3 Depress the ADF Latch Cap until you can reach the screw with a magnetic screwdriver.

CAUTION

Be careful not to drop the screw.

- 4 Remove the TP screw (m3x8).

To replace

- 1 Depress the lever for the ADF Latch Cap until the screw hole is accessible.
- 2 Use a magnetic screwdriver to place the screw in the hole.
- 3 Replace the ADF Latch Cap and tighten the screw.

ADF Cover

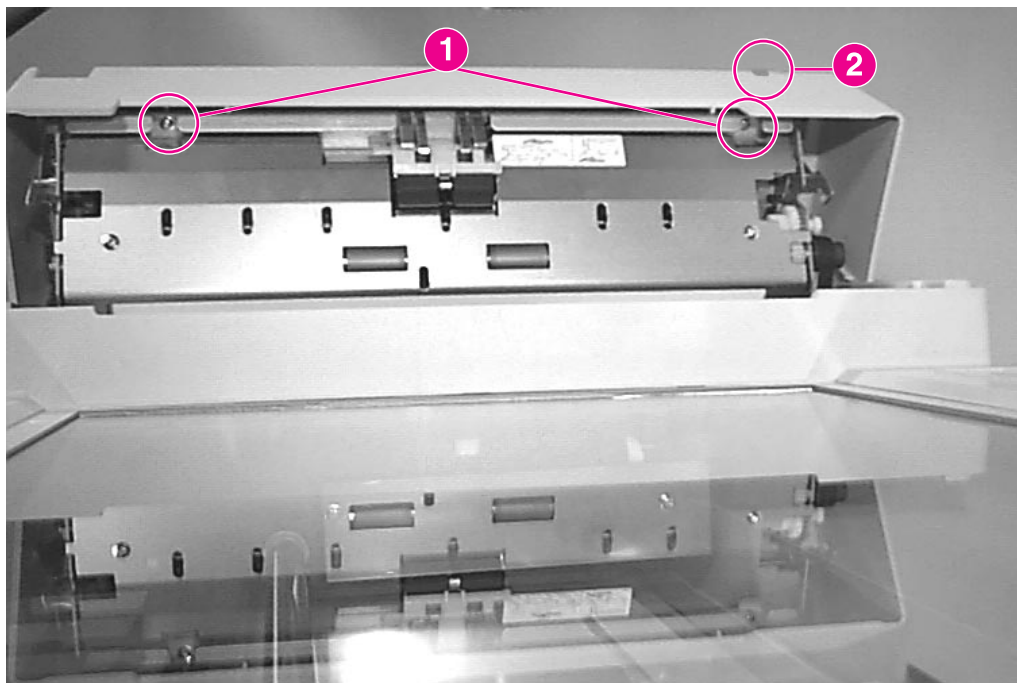

Figure 6-206 ADF Cover (1 of 2)

- 1 Open the ADF and remove 2 TP screws (m3x8) (callout 1).
- 2 Close the ADF.

Note

Note the location of the LED (callout 2). Be careful not to damage the LED Assembly underneath when you remove the ADF Cover.

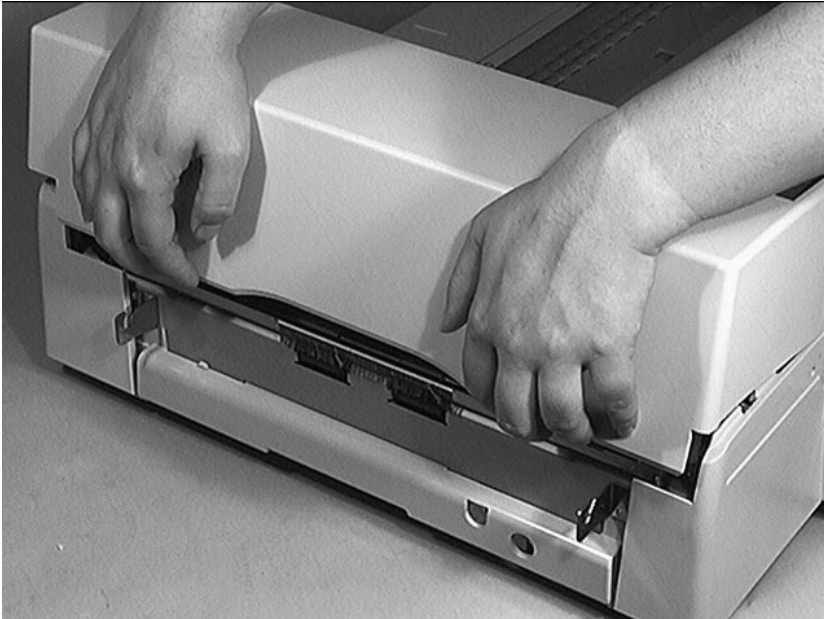

Figure 6-207 ADF Cover (2 of 2)

CAUTION

Be careful not to damage the LED Assembly when you remove the ADF Cover.

- 3 To remove the ADF Cover, pry outward to release the plastic tabs, and then pry the cover upward with your fingers as shown.

Front Panel

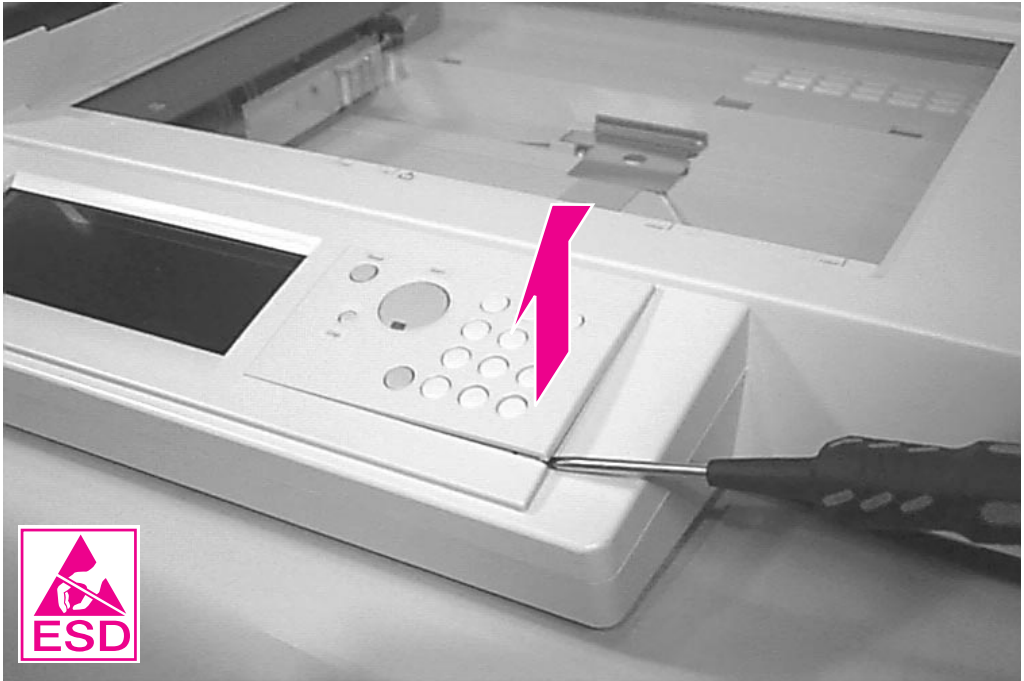

Figure 6-208 Front Panel (1 of 2)

- 1 Pry up the corner of the Front Panel overlay with a flat-blade screwdriver.
- 2 Lift off the overlay.

Note

The Front Panel can be removed while still attached to the Panel Cover. If this assembly is being removed to access the Flatbed Assemblies, go to “Panel Cover” on page 459.

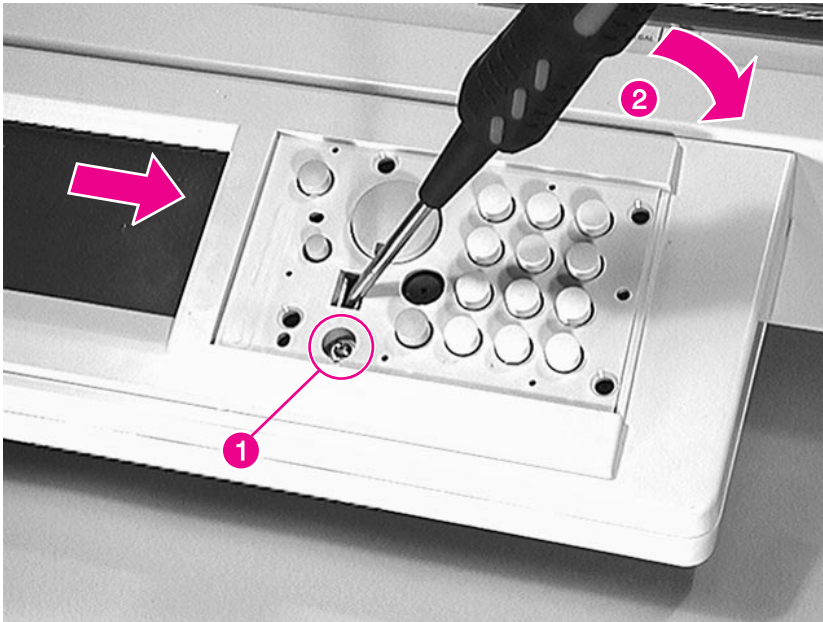

Figure 6-209 Front Panel (2 of 2)

- 3 Remove 1 TP screw (m3x8) (callout 1).
- 4 Insert a flat-blade screwdriver into the slot and push the handle to the right (callout 2) to pry the Front Panel loose, as shown by the arrow.

CAUTION

Be careful not to pull the connecting cable when you remove the Front Panel.

- 5 Remove the Front Panel.

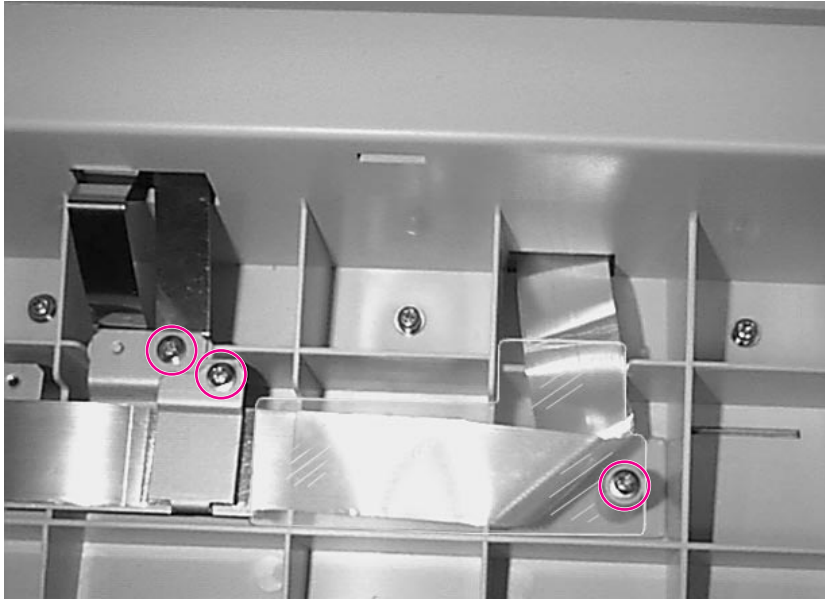

Figure 6-210 Front Panel Cable Clamp and Front Panel Frame Ground Plate

- 6 Remove 3 screws. Remove the Front Panel Cable Clamp and Front Panel Frame Ground Plate in order to remove the Ribbon Cable.

To replace

Be sure to place the top part of the Front Panel Cable Clamp on the exposed metal.

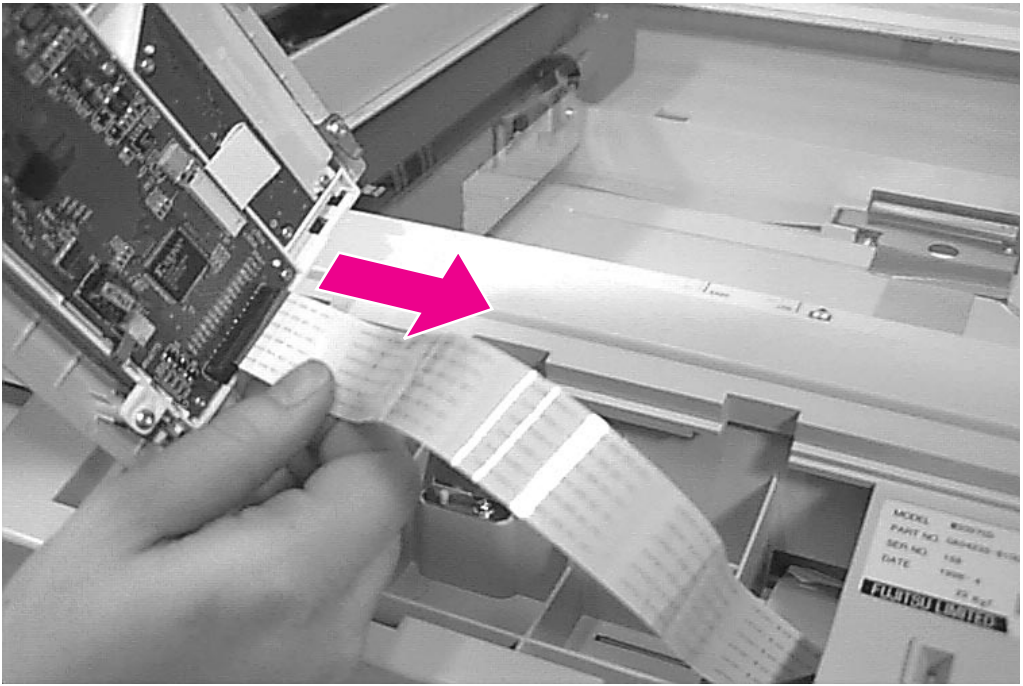

Figure 6-211 Front Panel Ribbon Cable

CAUTION

Handle the Ribbon Cable with care. Always release the connector before you pull on the cable. See the next page.

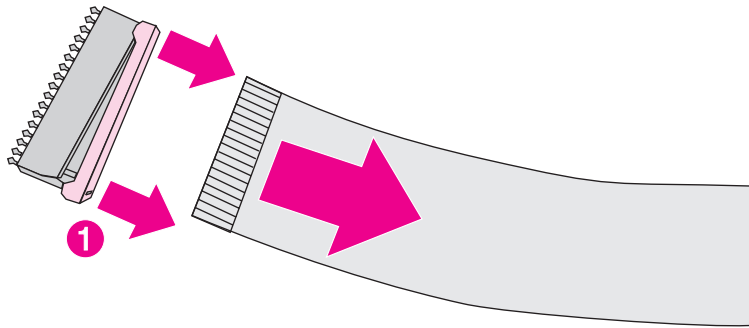

Figure 6-212 Unplugging the Ribbon Cable

- 7 To release the Ribbon Cable, use your fingernail to gently pull up each end of the connector (callout 1). Unplug the ribbon cable. Note the orientation of the contacts on the cable so the cable is not twisted.

To replace

- 1 Plug the cable into the connector. When the cable is inserted in the connector, the contacts point toward the middle of the Front Panel as shown in Figure 6-211. This also allows the cable to lie flat.
- 2 Press down the upper center of the Front Panel to engage the tabs as you push the Front Panel to the left, into place.

Panel Cover

CAUTION

Do not tip up the HP Digital Copy 320.

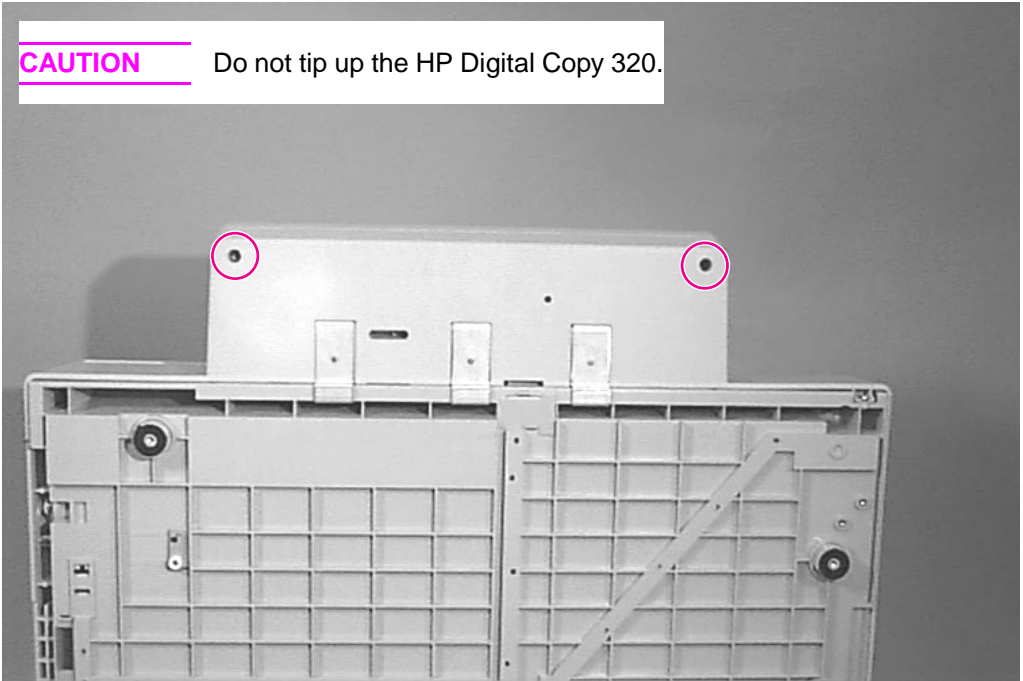

Figure 6-213 Panel Cover (bottom view)

CAUTION

Do not tip up the HP Digital Copy 320. Slide it to the edge of the table just far enough to access the screws.

- 1 Slide the HP Digital Copy 320 to the edge of the table.
- 2 Remove 2 TP screws (m3x8) underneath the Front Panel.
- 3 Lift up and pull out the Panel Cover.

Front Panel Brackets



Figure 6-214 Front Panel Brackets (1 of 2)

- 1 Remove 3 (brass machine screw m4x8 with washer) screws.

CAUTION

Do not tip up the HP Digital Copy 320.

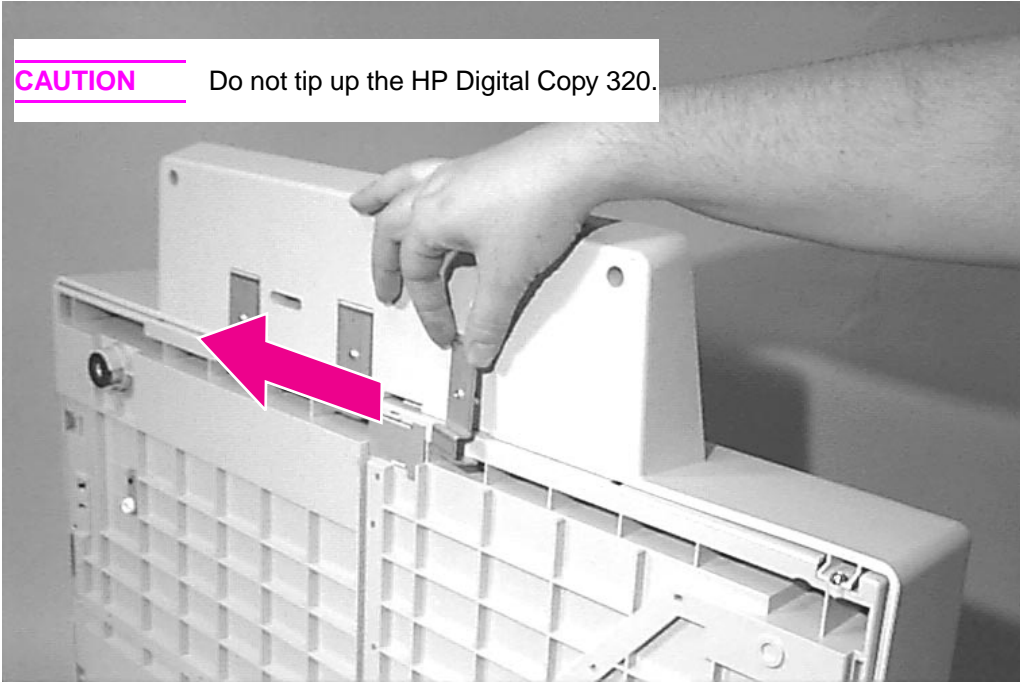

Figure 6-215 Front Panel Brackets (2 of 2)

CAUTION

Do not tip up the HP Digital Copy 320. Slide it to the edge of the table to access the bottom.

- 2 Slide the HP Digital Copy 320 to the edge of the table. Remove the brackets.

Upper Cover

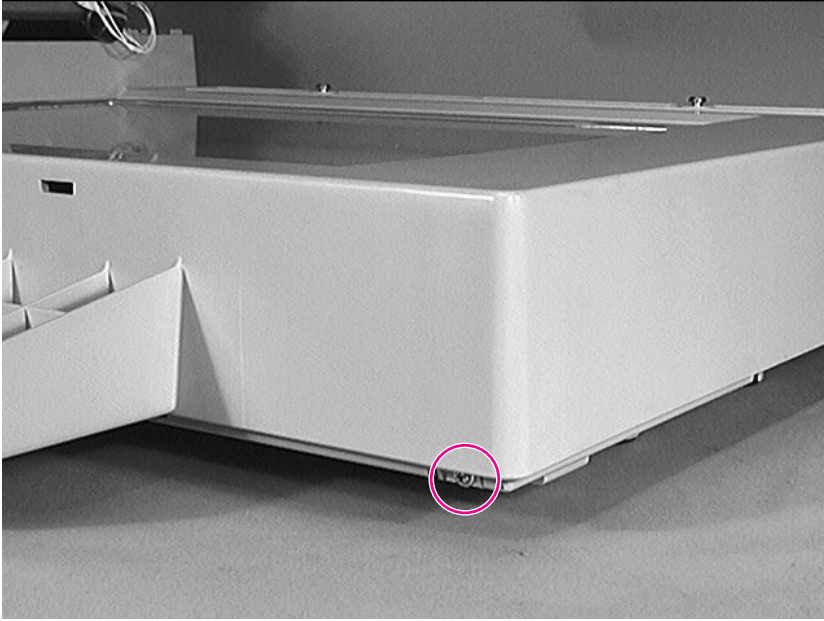

Figure 6-216 Upper Cover (1 of 2)

- 1 Remove the TP screw (m3x8) from the front right corner.

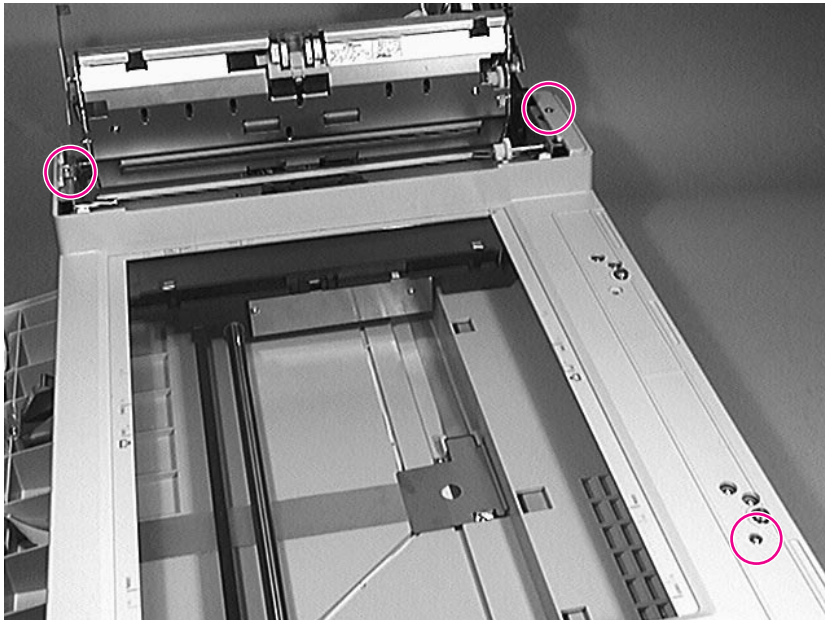

Figure 6-217 Upper Cover (2 of 2)

- 2 Remove 3 screws [two TP screws (m3x6) and one TP screw (m3x8)].

Note

For replacement, the screws in the ADF are longer.

The ADF is shown open to locate the screws. Always close the ADF to remove the Upper Cover.

CAUTION

Be careful of the LED PCA and Front Panel ribbon cable when you remove the cover.

- 3 Lift the Upper Cover straight up to remove it.

To replace

Carefully feed the Front Panel ribbon cable through the slot.

Copy Module Power Supply/Main Board Assemblies

WARNING!

Make sure the power is off and the main power to the system has been disconnected before servicing. See “Electrostatic Discharge (ESD) Precautions” on page 202.

The Power Supply and Main Board Tray contains the Copy Processor Board, the Power Supply, and the Control PCA.

Copy Processor Board

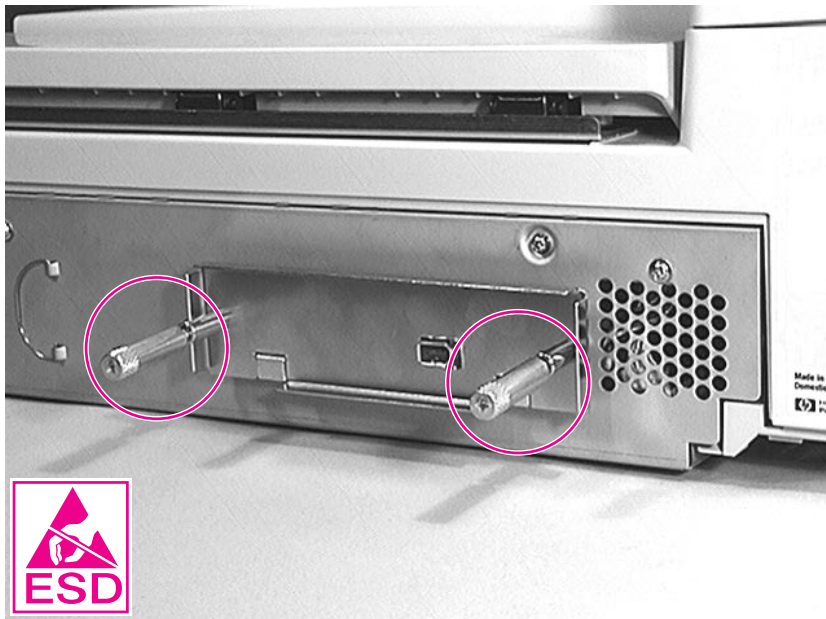

Figure 6-218 Copy Processor Board

CAUTION

The Copy Processor Board is ESD sensitive.

- 1 Remove 2 thumb screws.
- 2 Slide the Copy Processor Board out.

Power Supply and Main Board Tray

WARNING!

Make sure the power is off and the main power to the system has been disconnected before servicing. See “Electrostatic Discharge (ESD) Precautions” on page 202.

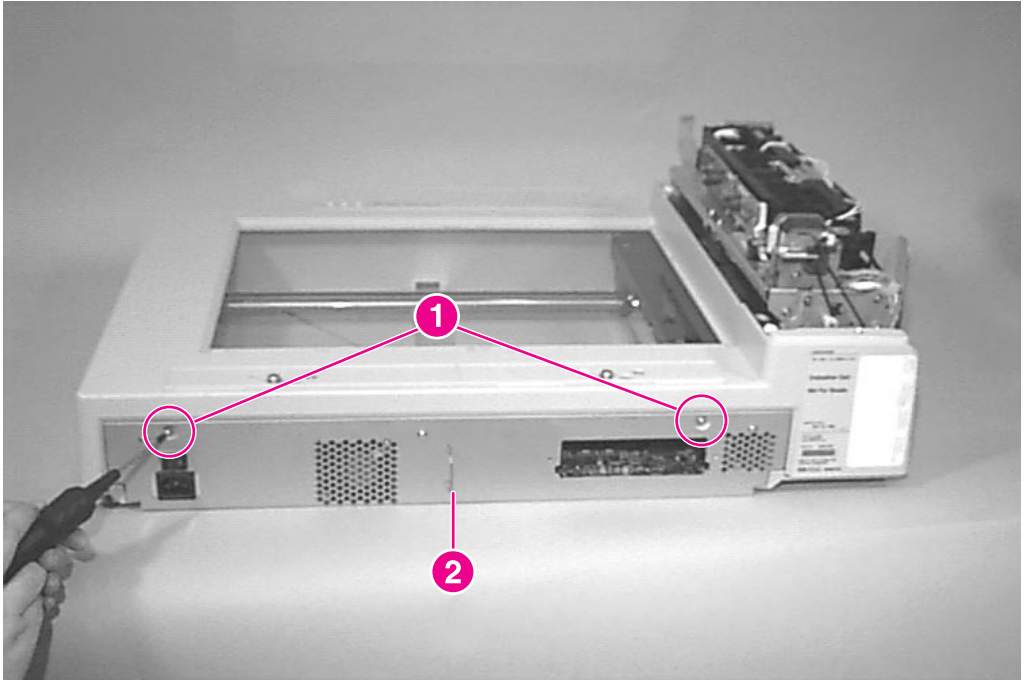

Figure 6-219 Power Supply and Main Board Tray (1 of 2)

- 1 Remove 2 brass machine screws with washers (m3x8) (callout 1).
- 2 Pull the Assembly out by the handle (callout 2) approximately 2.5 inches (6 centimeters).



Figure 6-220 Power Supply and Main Board Tray (2 of 2)

- 3 Unplug 3 connectors.
- 4 Remove the tray.

RFI Cover

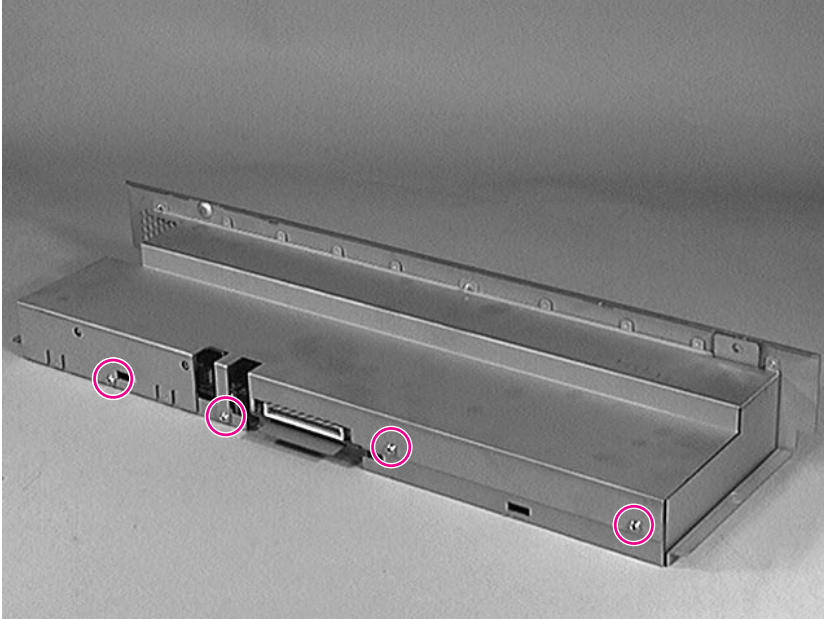

Figure 6-221 RFI Cover (inside/rear view)

Remove the RFI Cover (Radio Frequency Interference shield) in order to replace the Control PCA, the Power Supply, or the Fan Assembly.

- 1 Remove 4 TP screws (m3x8) from the rear of the RFI Cover.

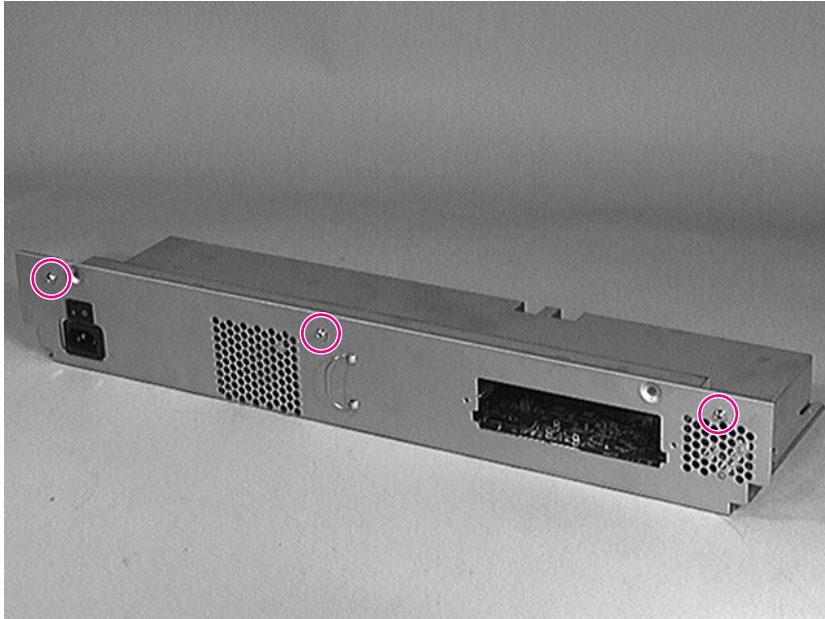

Figure 6-222 RFI Cover (outside/front view)

- 1 Remove 3 TP screws (m3x8) from the front of the RFI Cover.
- 2 Remove the RFI Cover.

Control PCA

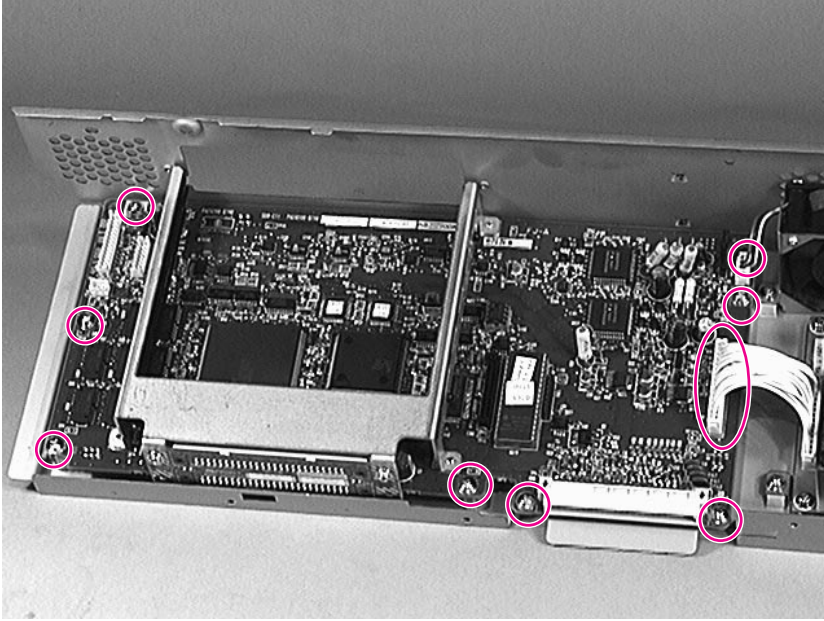

Figure 6-223 Control PCA

- 1 Remove the Power Supply and Main Board Tray and the RFI Cover.
- 2 Remove 7 TP screws (m3x8).
- 3 Unplug 2 connectors.
- 4 Remove the Control PCA. Retain the EEPROM (page 471), Back PCA (page 474) and the Card Cage (page 470).

Card Cage

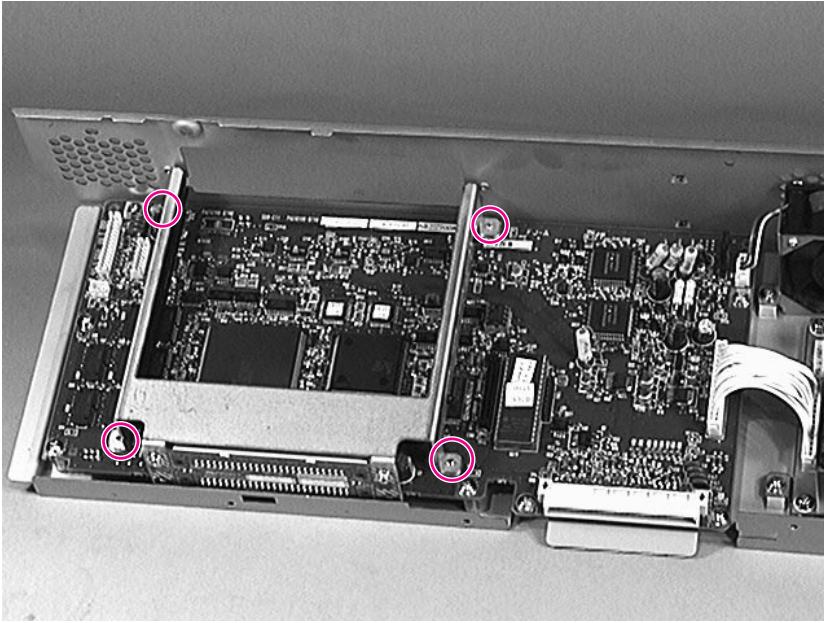

Figure 6-224 Card Cage

Note

To remove the Card Cage, flip over the Control PCA and remove 4 TP screws (m3x8).

EEPROM

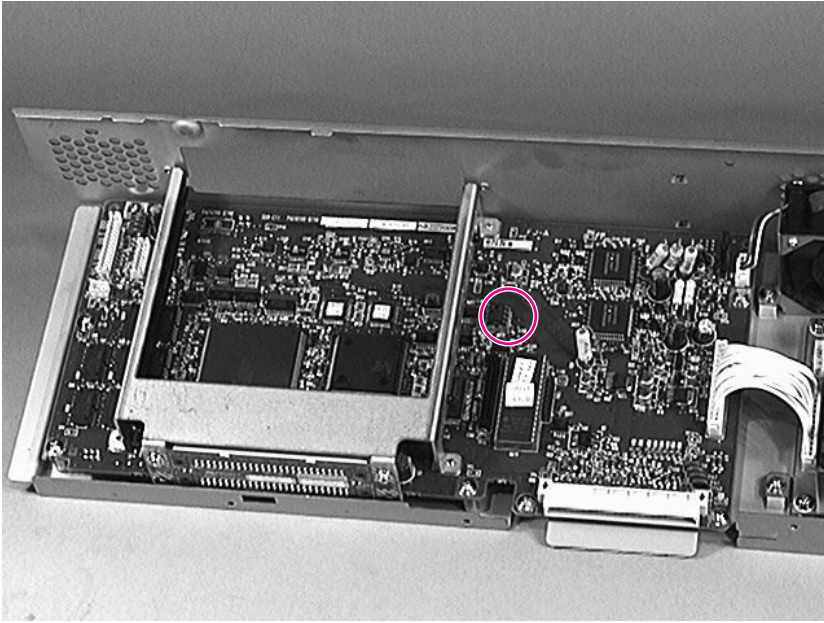

Figure 6-225 EEPROM

When you replace the Control PCA, retain the EEPROM from the old PCA and replace it on the new PCA in order to retain the default settings (such as calibration) for the HP Digital Copy 320.

Fan

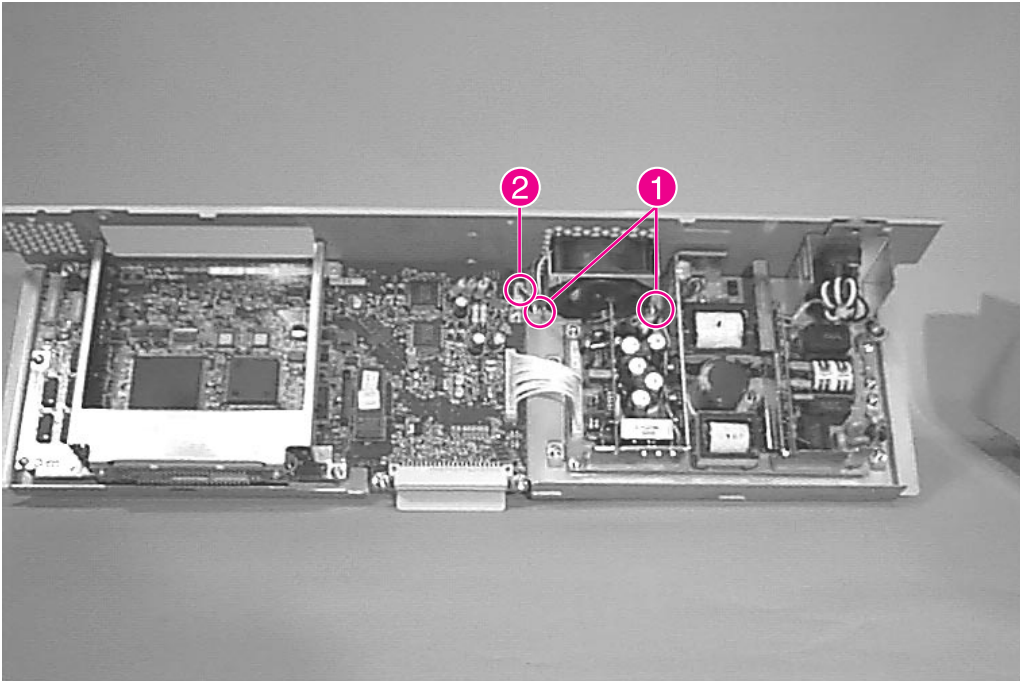

Figure 6-226 Fan

- 1 Remove the Power Supply and Main Board Tray and the RFI Cover.
- 2 Remove 2 TP screws (m3x8) (callout 1).
- 3 Unplug the connector (callout 2).

Power Supply

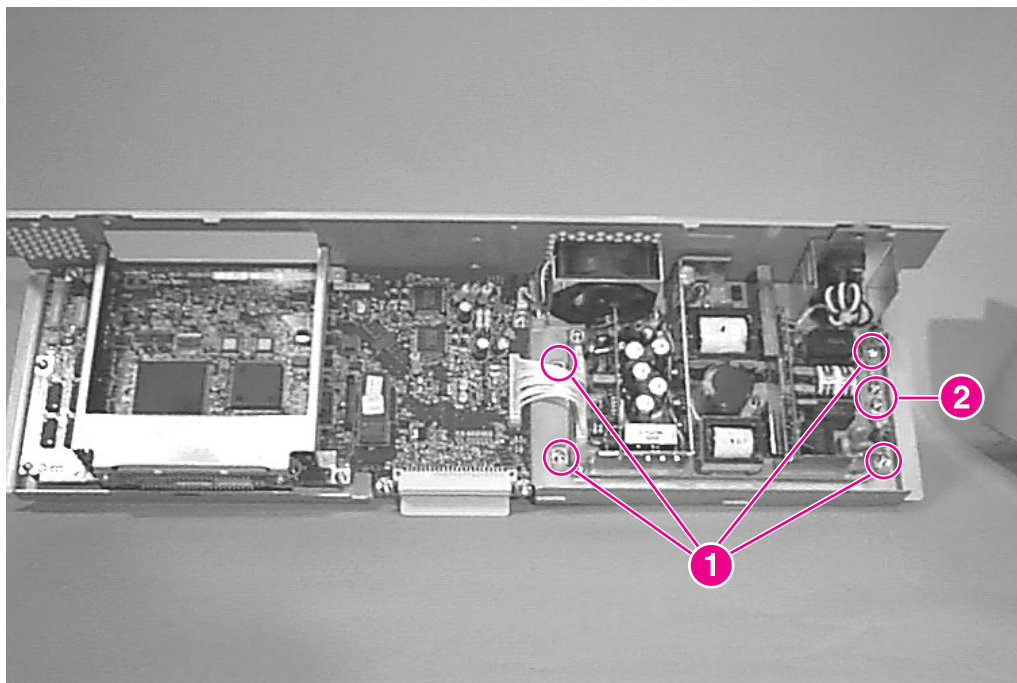

Figure 6-227 Power Supply

- 1 Remove the Power Supply and Main Board Tray and the RFI Cover.
- 2 Remove 4 TP screws (m3x8) (callout 1).
- 3 Remove 2 brass machine screws m4x8 with washer (callout 2).

Back PCA

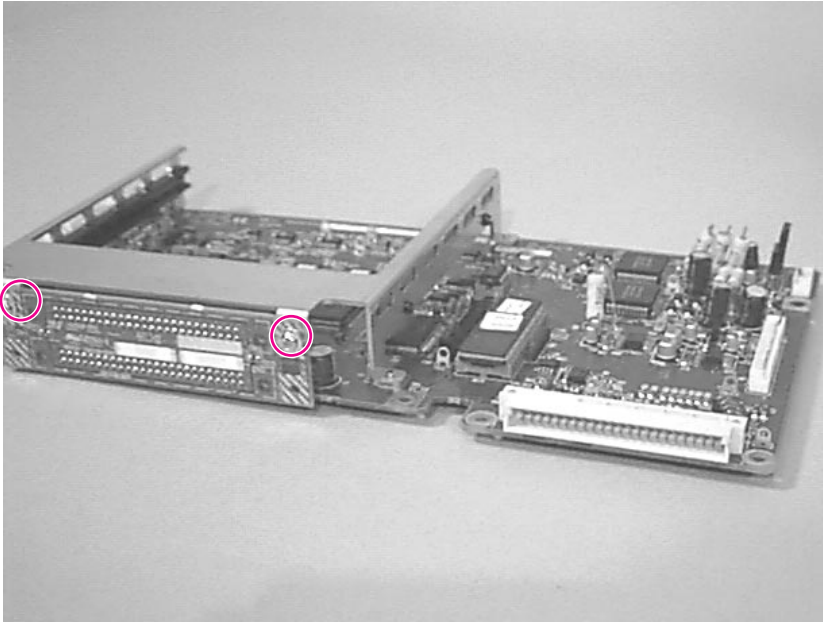

Figure 6-228 Back PCA

- 1 Remove the Power Supply and Main Board Tray and the RFI Cover. Remove the Control PCA (page 469).
- 2 Remove 2 TP screws (m3x8).
- 3 Pull out the Back PCA.

Note The board is keyed for correct insertion.

Copy Module ADF Unit Assemblies

Note

To access the ADF Unit Assemblies, remove the skins down to the ADF Cover (pages 445 to 452).

Optical Unit

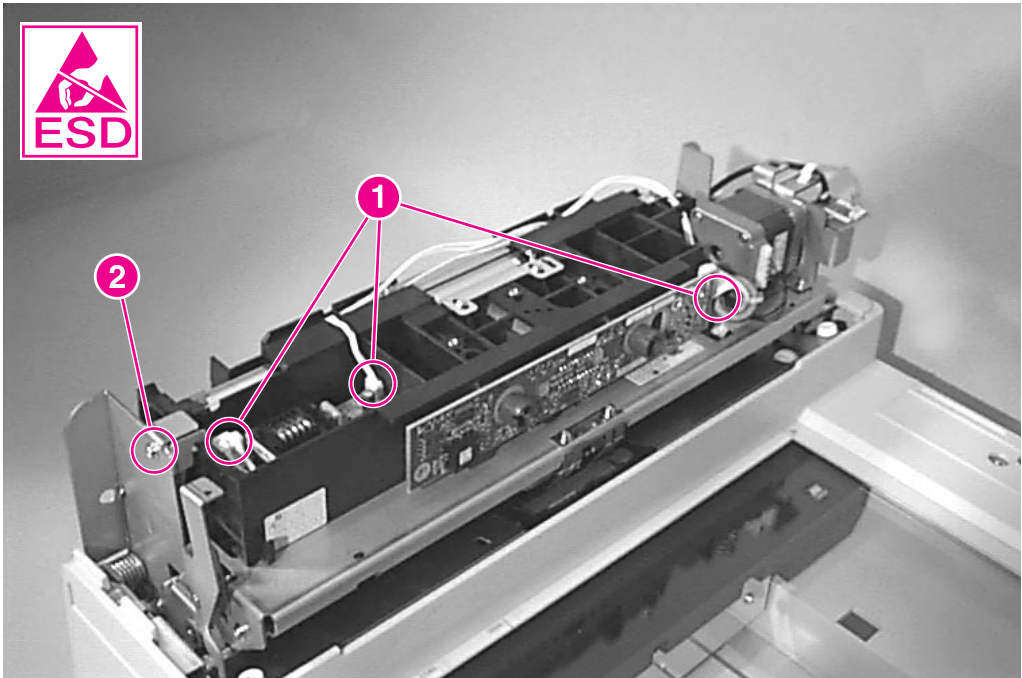

Figure 6-229 Optical Unit (1 of 2)

CAUTION

The Optical Unit is ESD sensitive.

- 1 Unplug 3 connectors (callout 1). Remove the cables from their routing guides. Note the routing of the cables in order to replace them in the correct positions. (Routing is also shown on page 486.)
- 2 Remove 1 TP screw (m3x8) and the Optical Unit Tie-down with Pad (callout 2).

CAUTION

Do not remove the CCD PCA or any of the screws on the Optical Unit other than the screws mentioned. Do not disassemble the Optical Unit.

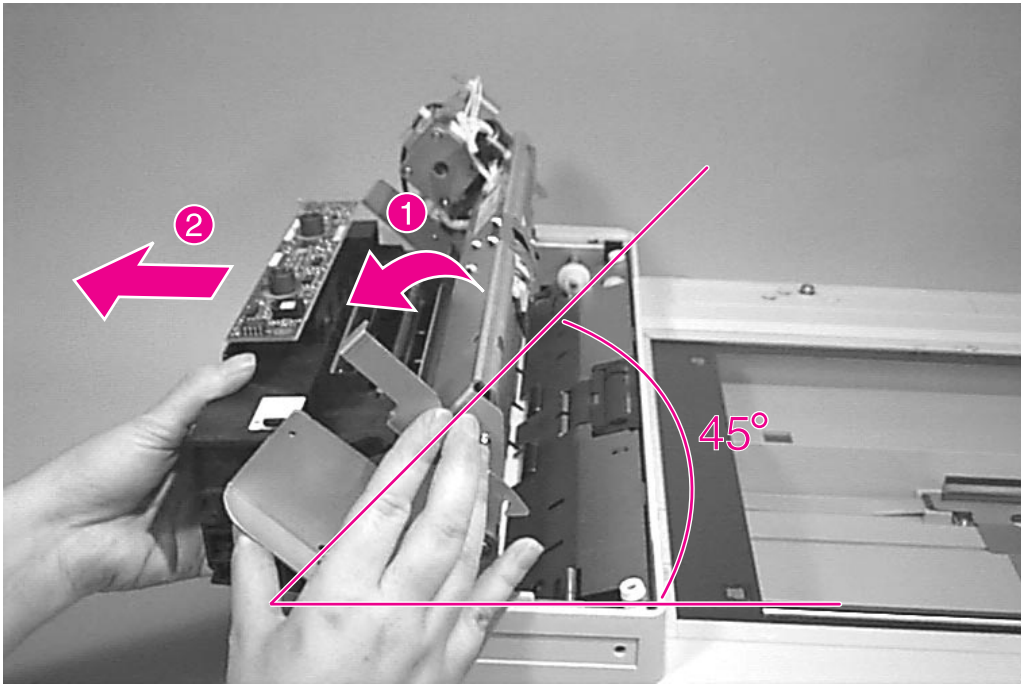

Figure 6-230 Optical Unit (2 of 2)

- 3 Holding the Optical Unit, release the ADF lever and open the ADF Assembly 45°. Rotate the Optical Unit as shown (the green board is on top and level) (callout 1).
- 4 Slide the Optical unit to the left off the slots in the metal bar (callout 2).

Note

The replacement Optical Unit includes a Back Side Lamp and Lamp Inverter PCA, but not an Optical Unit Tie-down with Pad.

ADF Lamp PCA

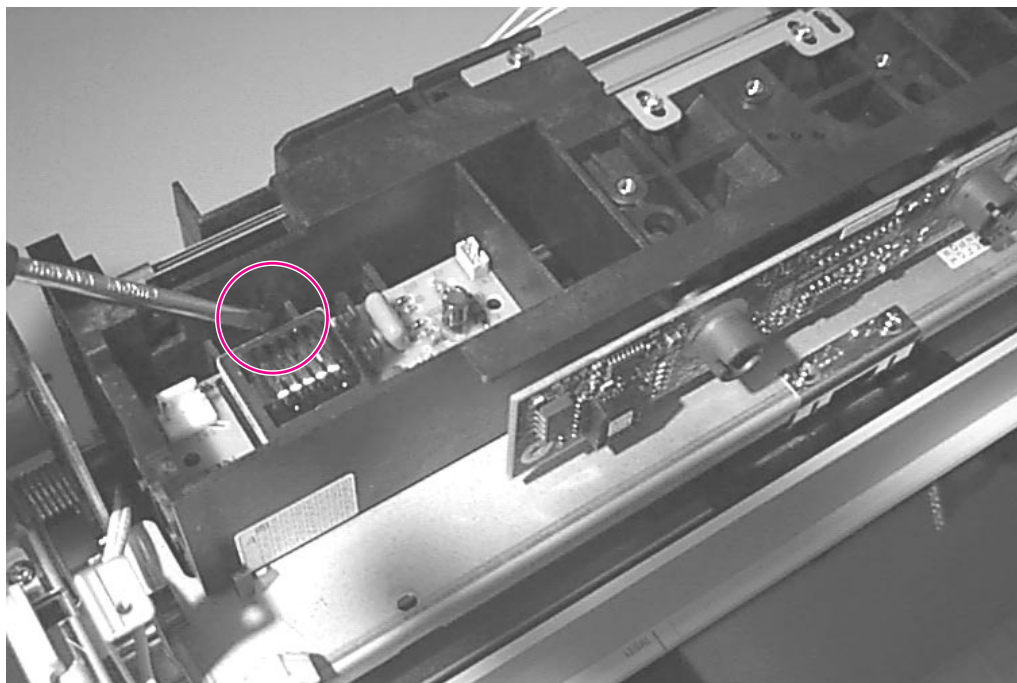

Figure 6-231 ADF Lamp PCA (1 of 2)

Note

It is not necessary to remove the Optical Unit to reach the ADF Lamp PCA.

CAUTION

Be careful not to damage the PCA as you remove it.

- 1 Use a flat-blade screwdriver to pry the tab loose.

CAUTION

Do not touch the Optical Unit Mirrors. Fingerprints will affect image quality.

To replace

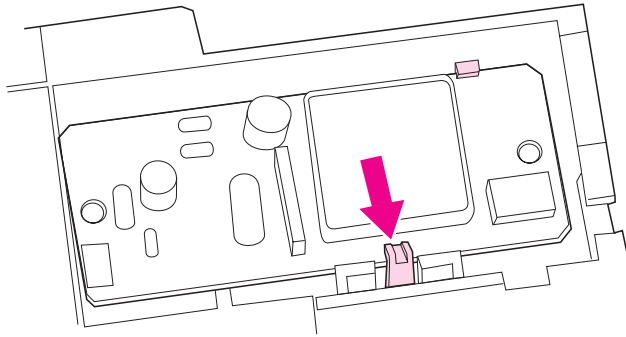

Figure 6-232 ADF Lamp PCA (2 of 2)

Note the orientation of the PCA to replace it in the correct position. The PCA fits under the tabs.

ADF Lamp

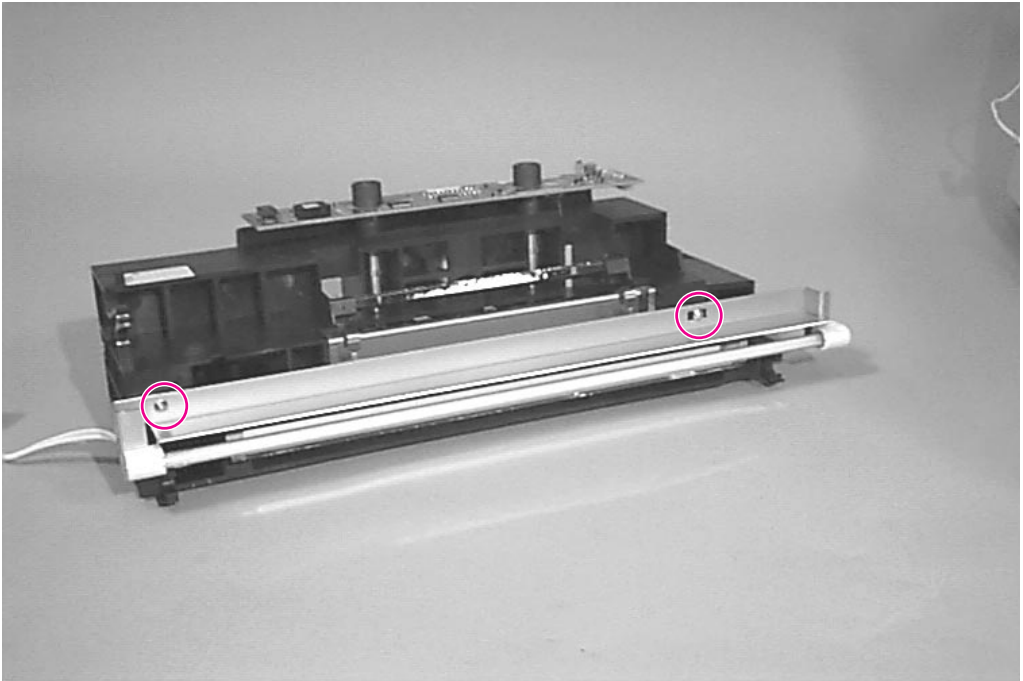

Figure 6-233 ADF Lamp

Remove 2 TP screws (m3x8).

CAUTION

Remove the Lamp carefully; it is fragile. Do not disassemble the Optical Unit beyond removal of the Lamp and Lamp PCA; it will be irreparably damaged!

To replace

Replace the screw nearest the Lamp cable first.

CAUTION

Do not over-tighten the screws holding the Lamp in place. Over-tightening the screws can damage the plastic.

Sensor Unit Assembly

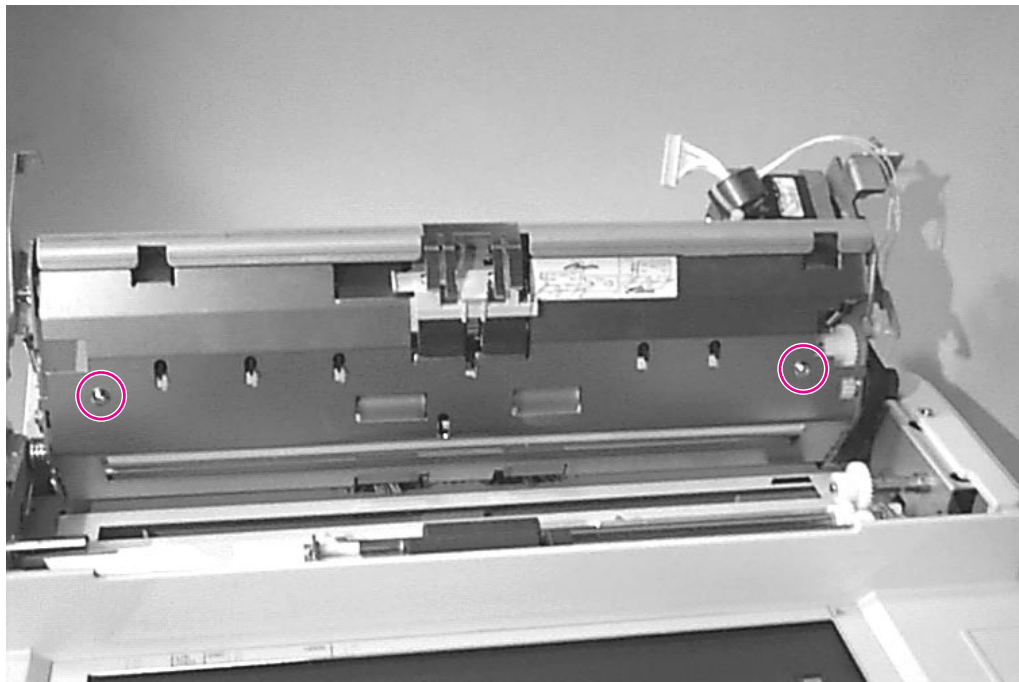

Figure 6-234 Sensor Unit Assembly (1 of 3)

- 1 Remove the Optical Unit.
- 2 Remove the Separation Pad (page 440).
- 3 Remove 2 TP screws (m3x8) as shown.

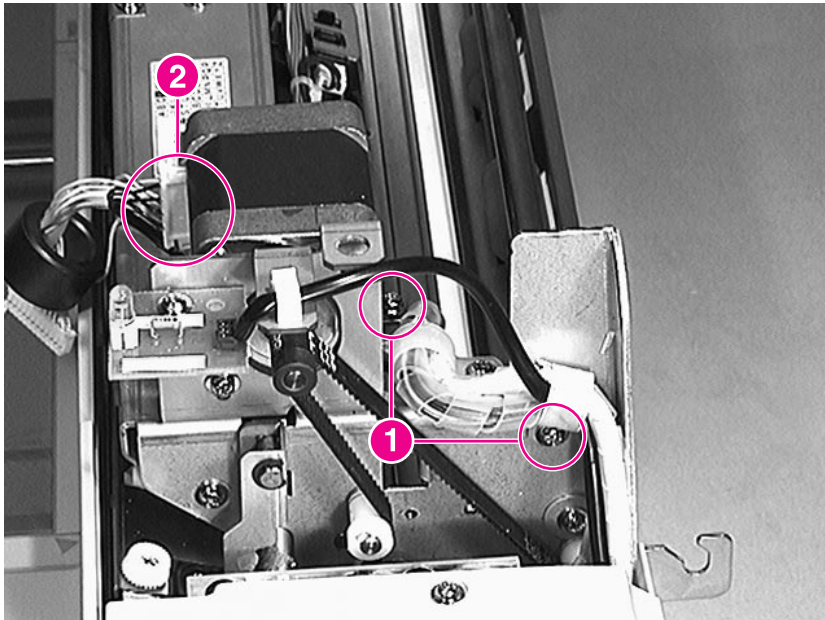

Figure 6-235 Sensor Unit Assembly (2 of 3)

- 4 Remove 1 TP screw (m3x8) from each of the 2 cable holders and remove the cables from the cable holders (callout 1).
- 5 Unplug 1 connector from the motor (callout 2).
- 6 Remove the cables from the wiring harness sleeve.

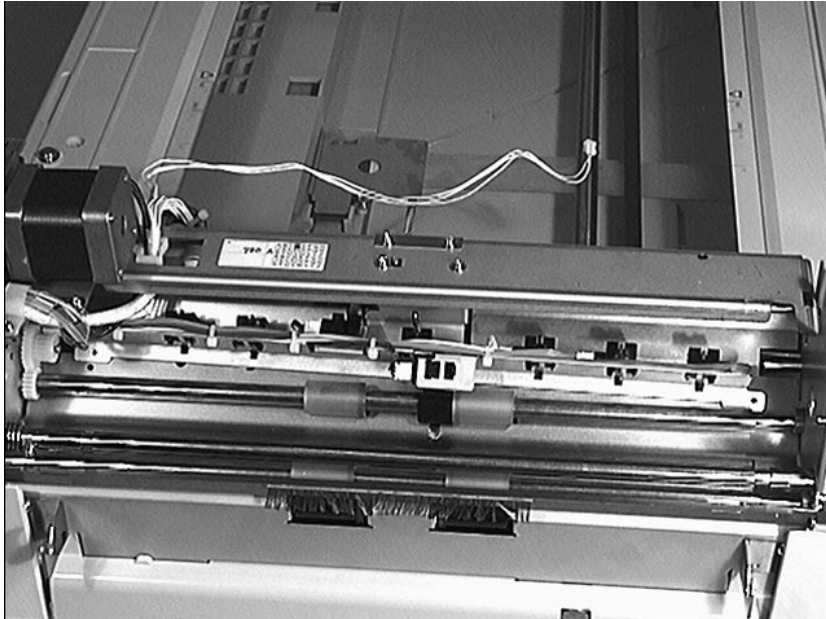

Figure 6-236 Sensor Unit Assembly (3 of 3)

- 7 Remove the Sensor Unit Assembly.

ADF Motor Unit

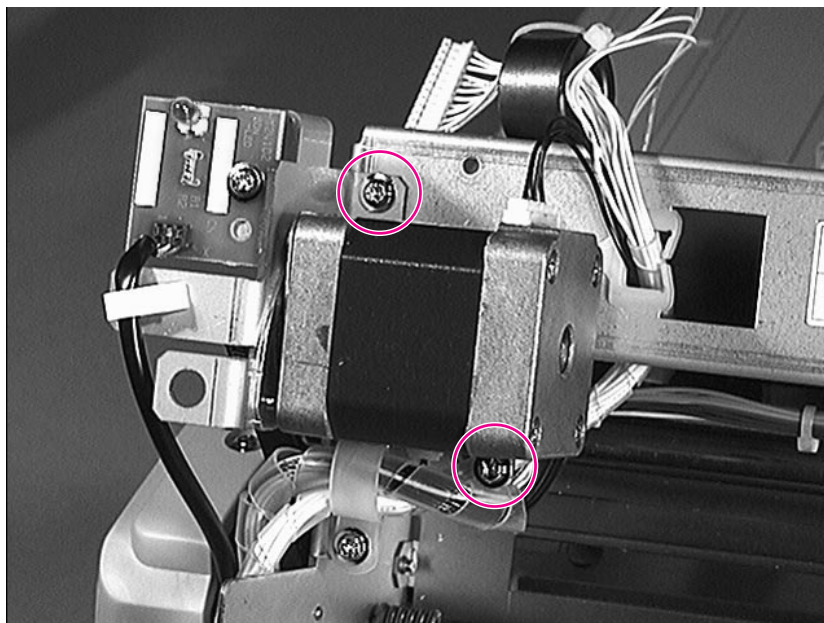

Figure 6-237 ADF Motor Unit

- 1 Remove the ADF Latch Cap (page 451) and the ADF Cover (page 452).
- 2 Unplug the connector from the ADF Motor.
- 3 Remove 2 TP screws (m3x8).
- 4 Move the belt out of the way.
- 5 Remove the ADF Motor.
- 6 Remove the belt (see the next page).

ADF Belt

- 1 Remove the ADF Latch Cap (page 451) and the ADF Cover (page 452).

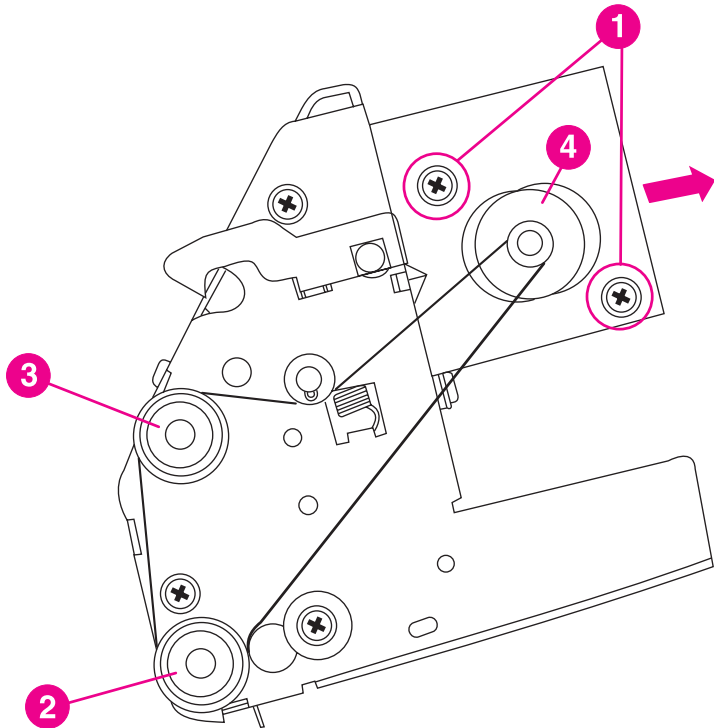

Figure 6-238 ADF Belt

- 2 Loosen 2 screws (callout 1) and remove the ADF Belt.

To replace

- 1 Place a new belt on pulleys 2 and 3 as shown.
- 2 Place the belt on pulley 4.

To adjust belt tension

- 1 Make sure the 2 screws (callout 1 in Figure 6-238) on the ADF Motor Unit are loose when you adjust the belt tension.
- 2 To adjust the belt tension, pull the motor up firmly (by hand only).

Note

It is very difficult to overtighten the belt tension by hand. A belt that is too loose, however, can adversely affect image quality.

- 3 Maintaining upward pressure on the motor, tighten the 2 screws (callout 1) on the ADF Motor Unit.

LED Assembly PCA

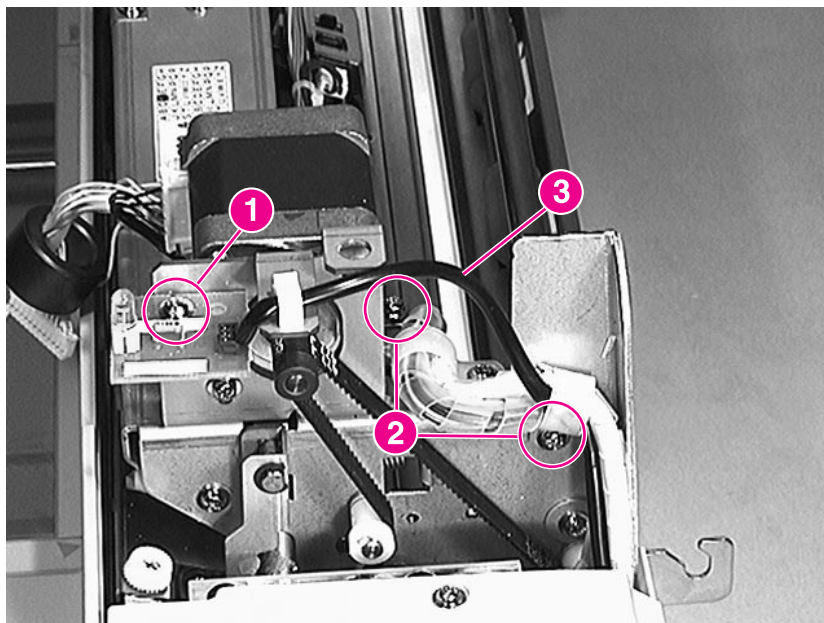

Figure 6-239 LED Assembly PCA

- 1 Remove the ADF Latch Cap (page 451) and the ADF Cover (page 452).
- 2 Remove 1 TP screw (m3x8) (callout 1).
- 3 Remove 1 TP screw (m3x8) from each of the 2 cable holders (callout 2) and remove the cables from the cable holders.

CAUTION

Do not attempt to unplug the connector from the PCA. It is permanently attached to the PCA on one end. Unplug the other end from the Main Board.

- 4 Unplug 1 connector from the Main Board.
- 5 Remove the cable (callout 3) from the wiring harness sleeve.

To replace

Note the PCA has 2 holes, one for the screw and one for the locating pin. Be sure to orient the PCA properly with the 2 holes.

ADF Unit

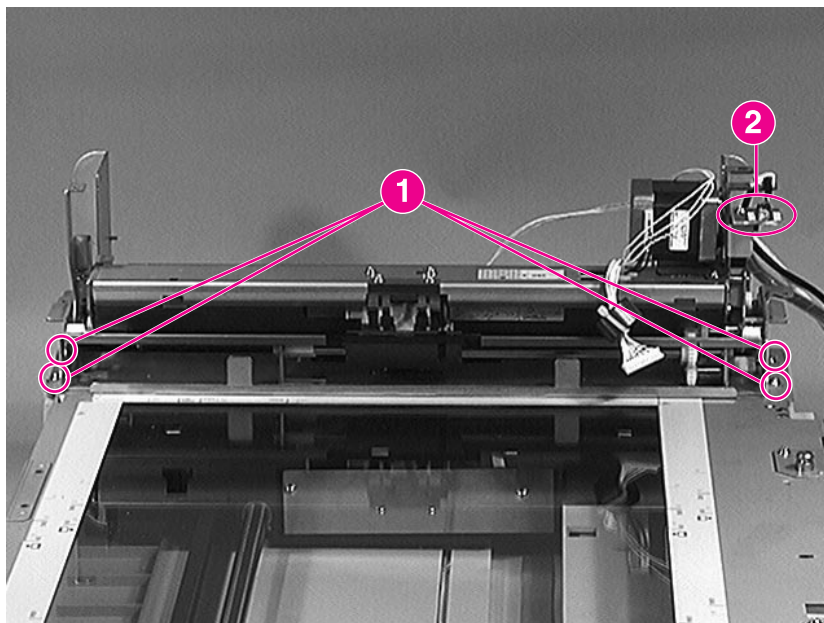

Figure 6-240 ADF Unit (shown without Optical Unit)

Note

To get to the Glass Plate assemblies, you can remove the ADF Unit with the Optical Unit intact. (An Optical Unit is not included with a replacement ADF Assembly.)

- 1 Remove 4 TP screws (m3x6) (callout 1) and unplug 3 cables from the Main Board Tray (shown in Figure 6-220 on page 466).

WARNING!

Once the ADF latch is removed, if the lever is triggered the ADF can spring open rapidly and pinch your fingers.

CAUTION

Be careful not to damage the LED Assembly (callout 2) when you are working around the ADF Unit.

- 2 Lift off the ADF Unit.

To replace

- 1 The ADF is keyed to the Glass Plate Assembly. Make sure it fits properly in its place before you replace the screws.
- 2 Always perform an offset adjustment whenever you replace the ADF. See “Calibrating the HP Digital Copy 320” on page 126.

Copy Module Flatbed Assemblies

Note

To access the Flatbed Assemblies, remove the skins (starting on page 445), including the Front Panel (starting on page 454) and the ADF Unit Assemblies (starting on page 475).

Front Panel Frame Ground Spring

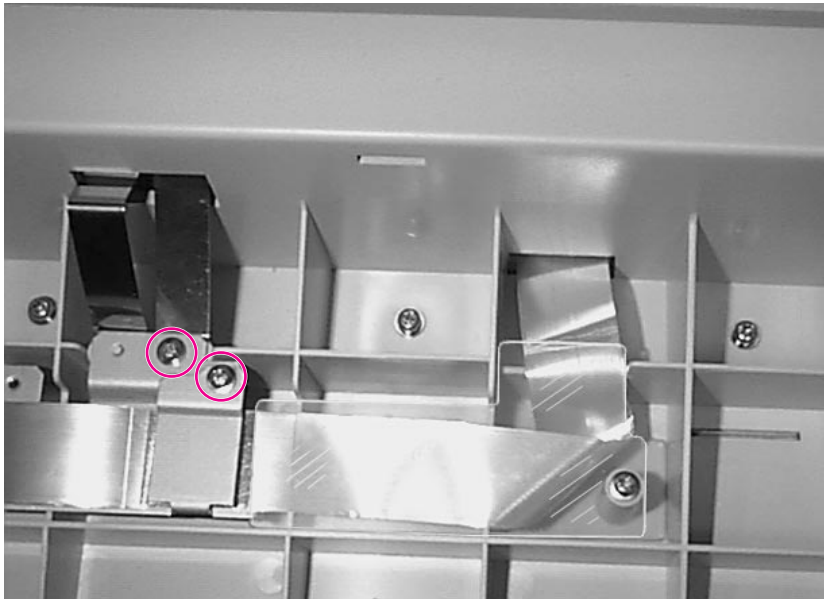

Figure 6-241 Front Panel Frame Ground Spring

- 1 Remove 2 TP screws (m3x8).
- 2 Remove the spring.

Output Tray Brackets

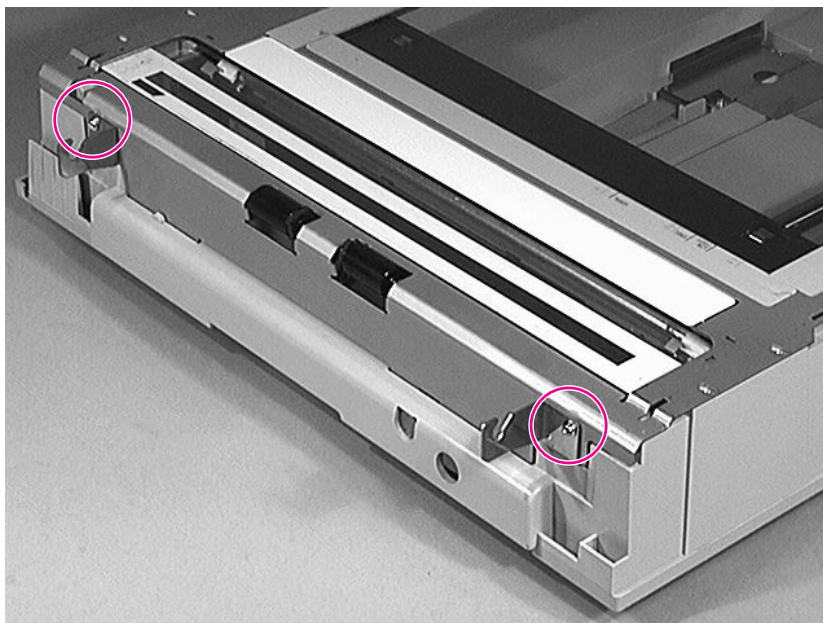

Figure 6-242 Output Tray Brackets

Remove 1 TP screw (m3x8) from each bracket and remove the bracket.

Glass Plate Assembly

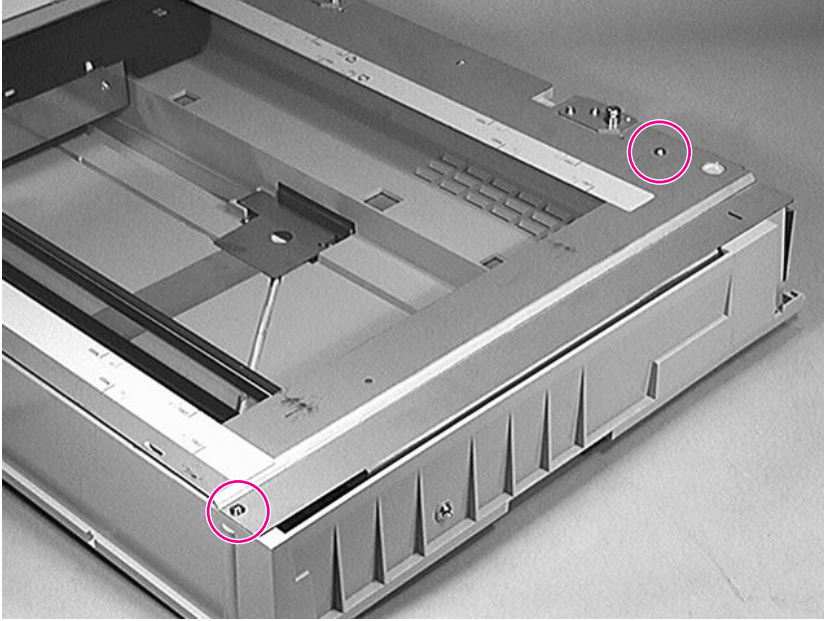

Figure 6-243 Glass Plate Assembly

- 1 Remove the ADF Unit (page 487). Output Tray Brackets and open the Power Supply and Main Board Tray.
- 2 Remove 2 TP screws (m3x8) as shown.

CAUTION

Remove the Glass Plate Assembly carefully; it is breakable.

- 3 Remove the Glass Plate Assembly.

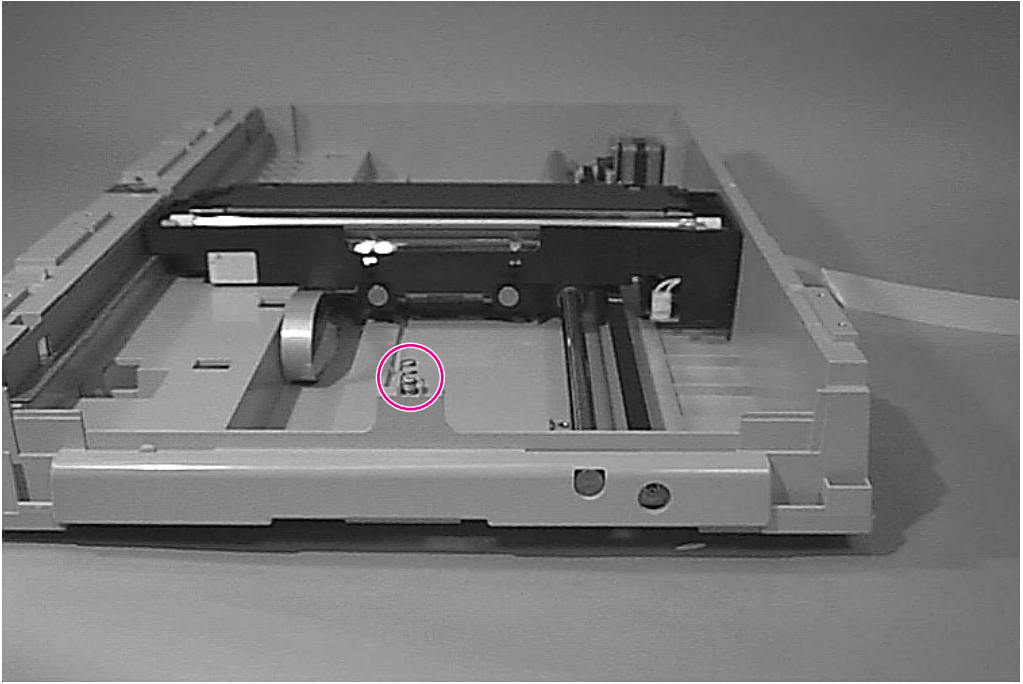

Figure 6-244 Idle Roller Coil Spring

Remove the Idle Roller Coil Spring.

To replace

Align the Idle Roller Coil Spring on the pin and press it into place.

Home Position Sensor

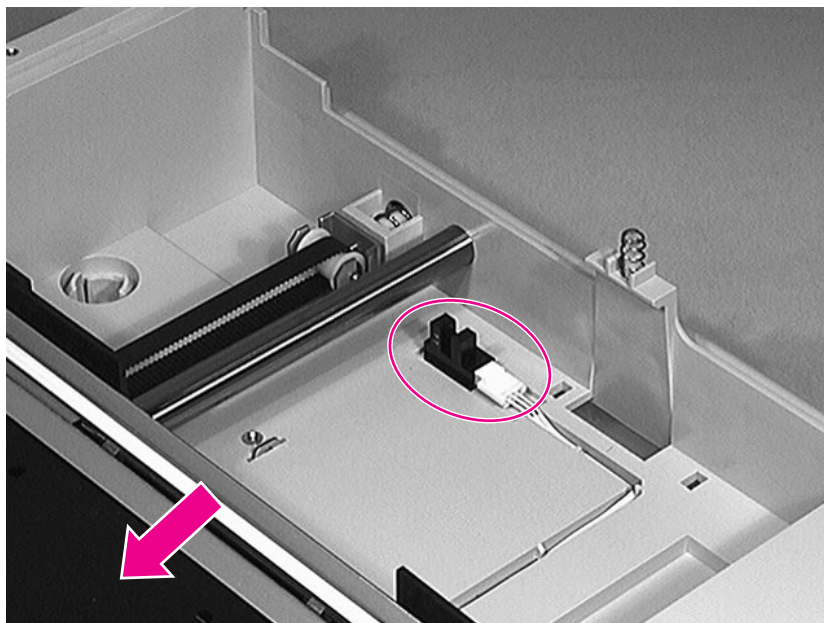

Figure 6-245 Home Position Sensor (1 of 2)

- 1 Move the Carrier Unit away from the sensor.



Figure 6-246 Home Position Sensor (2 of 2)

- 2 From underneath, pry the tabs to release the sensor.
- 3 Unplug the connector. (The cable is included with the Junction PCA.)

Carrier Unit Lamp

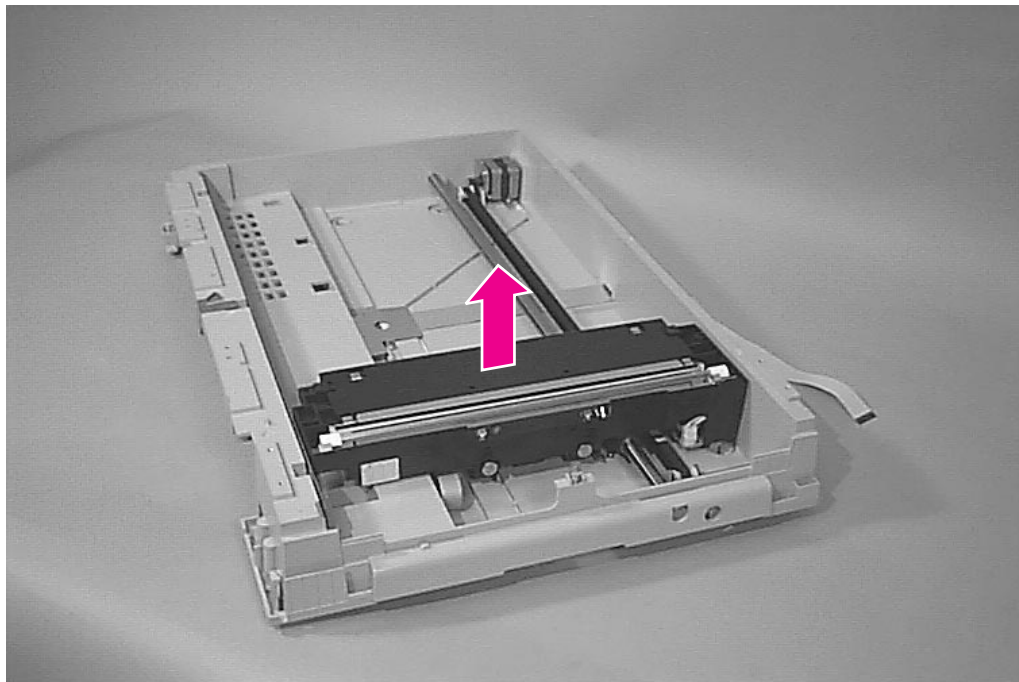

Figure 6-247 Dust Cover

- 1 Remove the Carrier Unit Dust Cover.

To replace

Place the dust cover shiny side down and underneath the long metal tab.

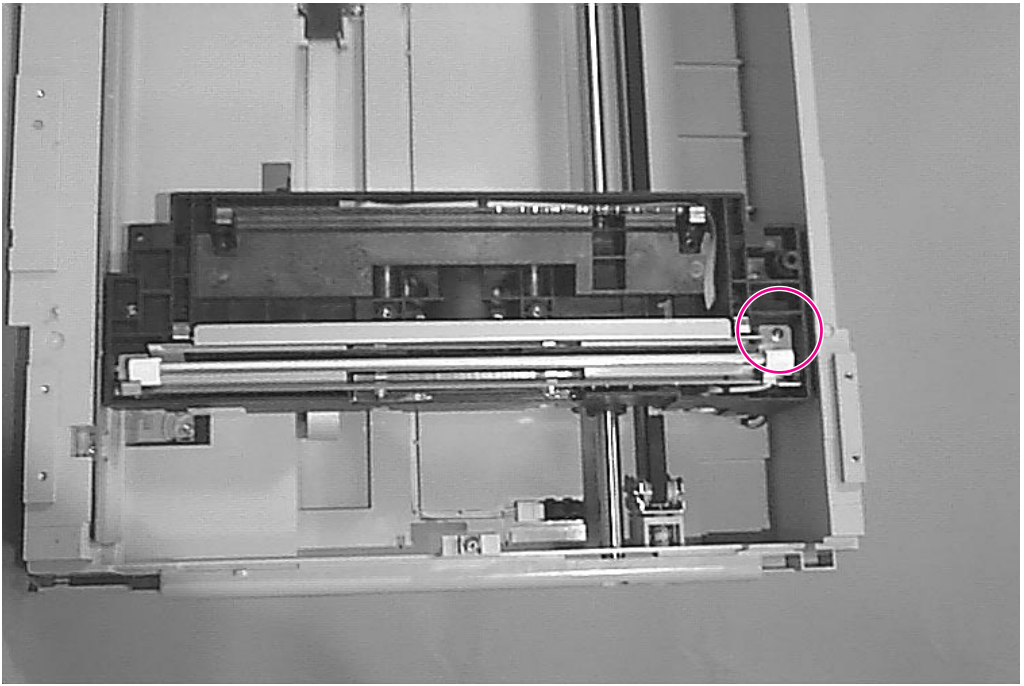

Figure 6-248 Lamp (1 of 2)

- 1 Remove 1 TP screw (m3x8).

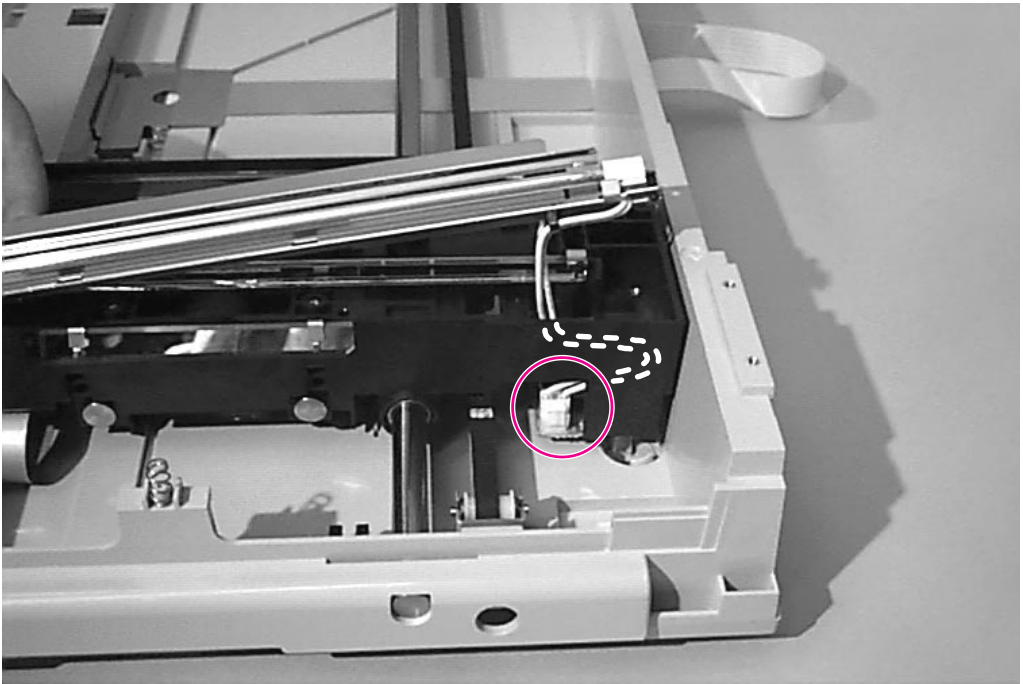

Figure 6-249 Lamp (2 of 2)

- 2 Unplug 1 connector.

CAUTION

When you replace the Lamp, be sure to replace the cable as far as possible into the recess of the corner of the Carrier Unit so it will not get pinched or cut.

Note

For replacement, the rear end of the Lamp goes in first.

Carrier Unit

CAUTION

Do not disassemble the Carrier Unit.

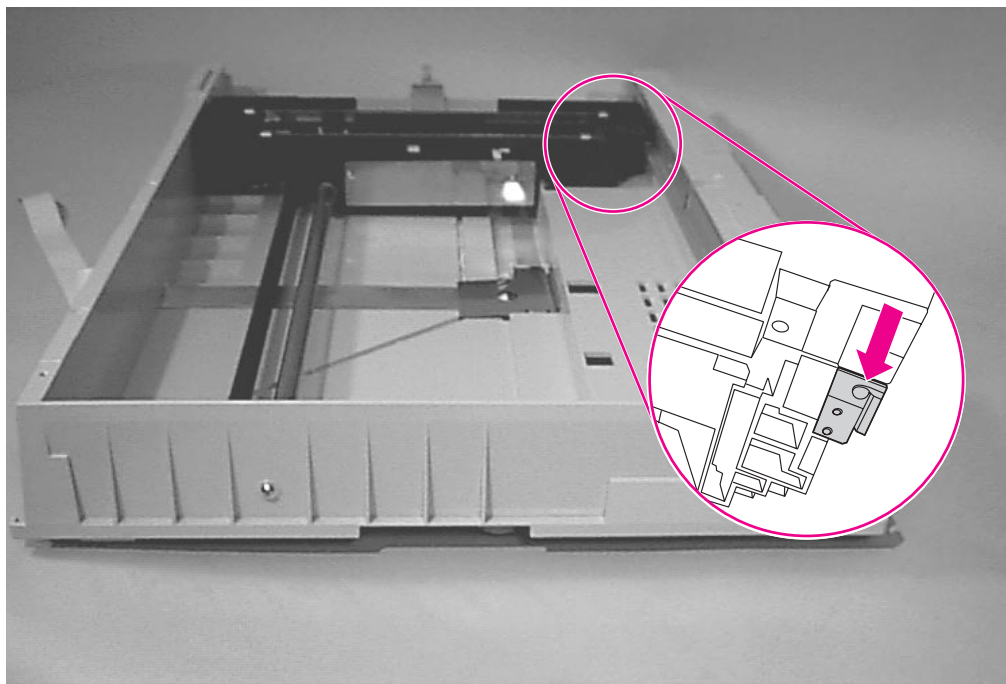

Figure 6-250 Carrier Unit (1 of 2)

- 1 Remove 1 screw from the end of the Carrier Shaft.

Note

When you replace the Carrier Unit, check the alignment of the rail and rail bushing. The metal bushing should fit into the rail instead of sitting on top.

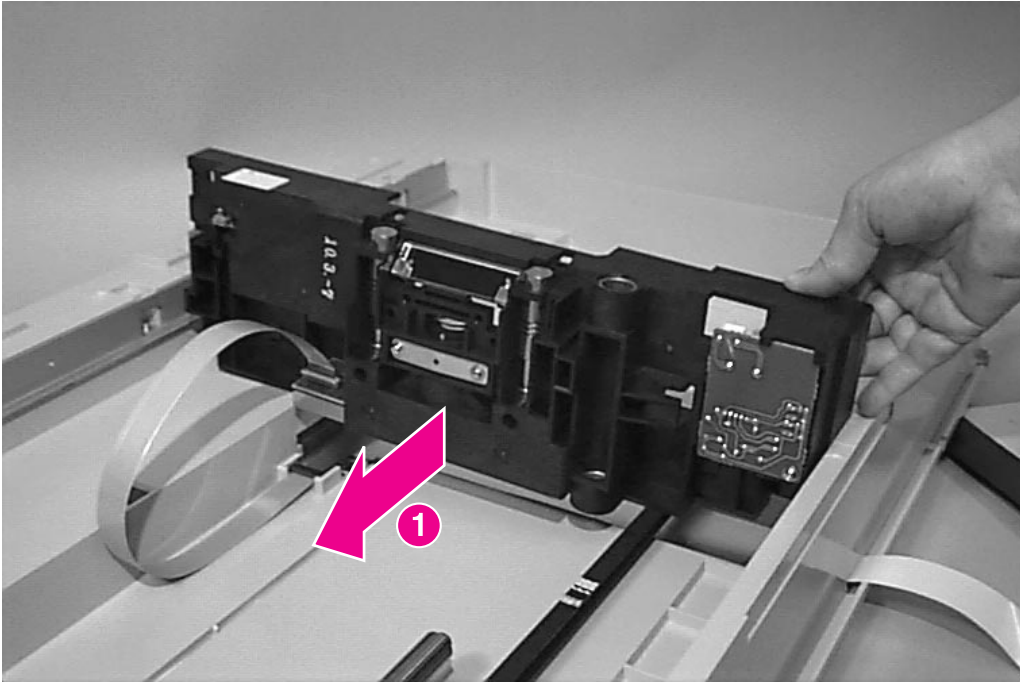

Figure 6-251 Carrier Unit (2 of 2)

- 2 Move the Carrier to the center (callout 1).
- 3 Pull out the Carrier Shaft.

Cleaning and Lubricating the Carrier Unit Shaft

- 1 If the Carrier Unit Shaft is dirty, wipe it off with a cloth, then relubricate it (see below). Otherwise, be careful not to remove the lubricant.
- 2 Place an even coating of Terrace Oil 46 (light weight oil) on the Carrier Unit Shaft as needed (for example, if paper dust or other material interferes with movement of the Carrier Unit, or if you have cleaned the shaft).

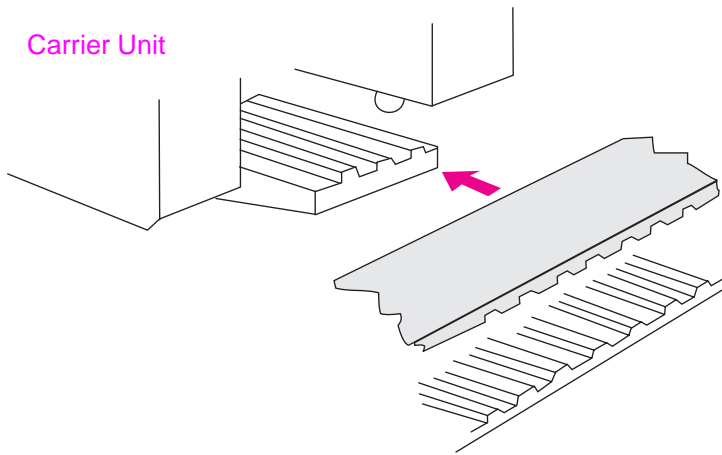

Figure 6-252 Carrier Belt

- 3 Slide the belt off the Carrier Unit.

CAUTION

Handle the Ribbon Cable with care. Always release the connector before you pull on the cable.

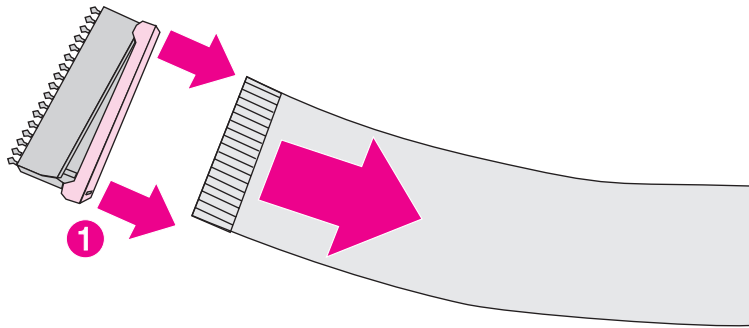

Figure 6-253 Unplugging the Ribbon Cable

- 4 To release the Ribbon Cable, use your fingernail to gently pull up each end of the connector (callout 1). Unplug the ribbon cable. Note the orientation of the contacts on the cable so the cable is not twisted.

CAUTION

During reassembly, when you insert the Carrier Shaft, be careful not to dislocate the Felt Pad in the Carrier Frame. See page 501.

- 5 Remove the Carrier Unit.

Note

The replacement Carrier Unit includes a Lamp, Dust Cover, and pre-lubricated Felt Pad. A ribbon cable is not included.

CAUTION

If the brass bushing comes off the rail, be sure to replace it so that the rail fits into the bushing's groove, and the bushing does not sit on top of the rail. If the bushing sits on top of the rail, it can block the Carrier Unit.

Felt Pad

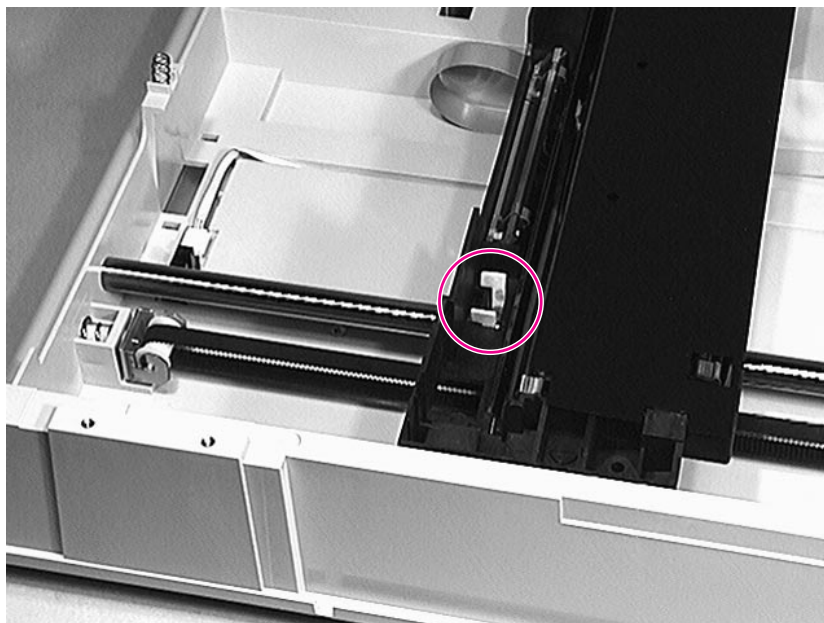

Figure 6-254 Felt Pad

- 1 Remove the Carrier Unit Lamp.
- 2 Insert the Felt Pad as shown.

Feet

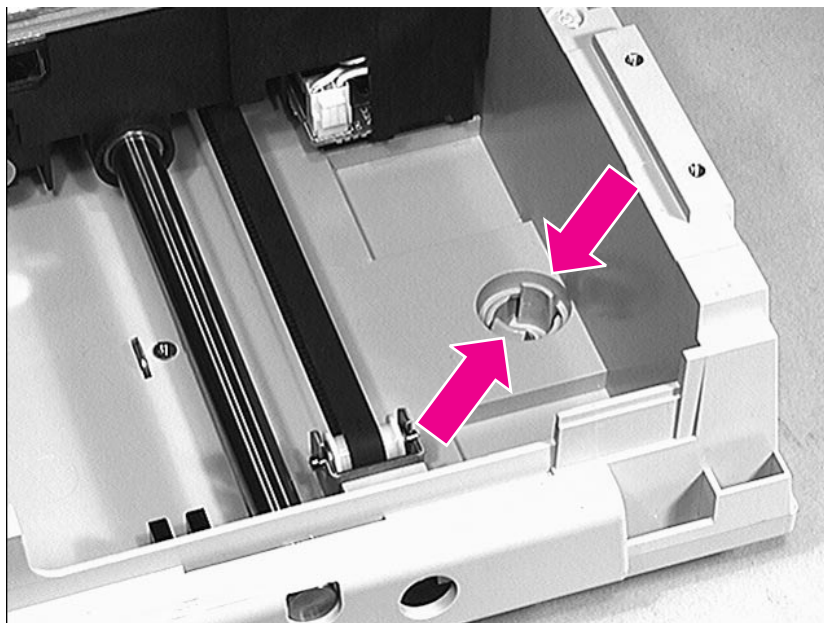

Figure 6-255 Feet

Pinch the tabs to remove the foot.

Frame Ground Spring

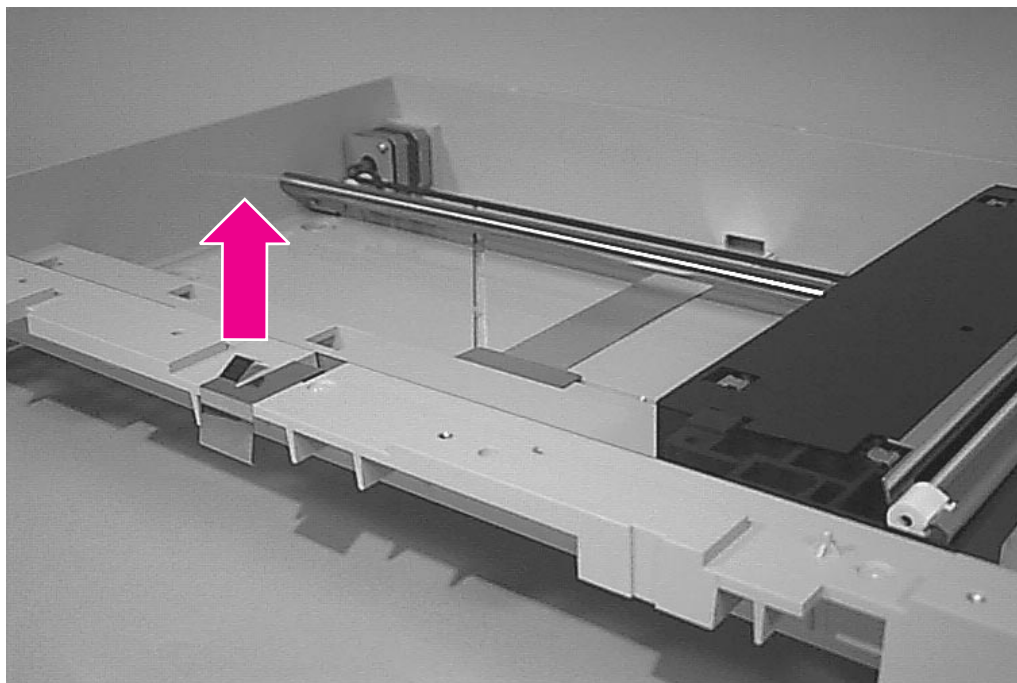

Figure 6-256 Frame Ground Spring

- 1 Lift out the Frame Ground Spring.

To replace

Align the spring and the grounding plate.

CAUTION

Do not forget to replace the Frame Ground Spring when you reassemble the HP Digital Copy 320.

Front Lamp PCA

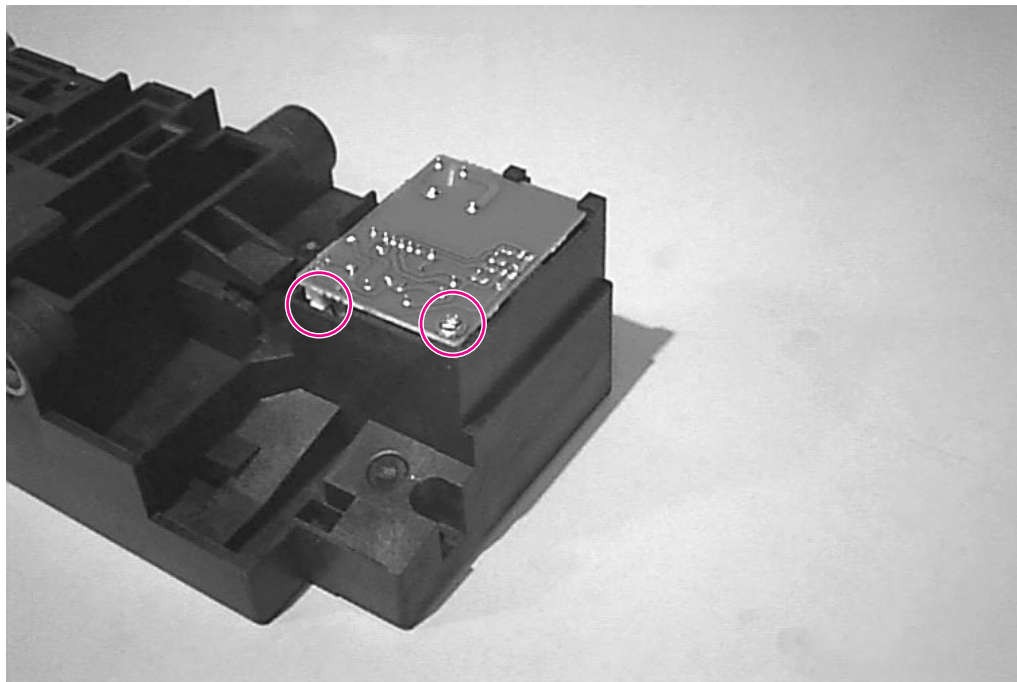

Figure 6-257 Front Lamp PCA

- 1 Remove the Carrier Unit. The Front Lamp PCA is located on the underside of the Carrier Unit.
- 2 Unplug 1 connector.
- 3 Remove 1 TP screw (m3x8).

Junction PCA and Cover

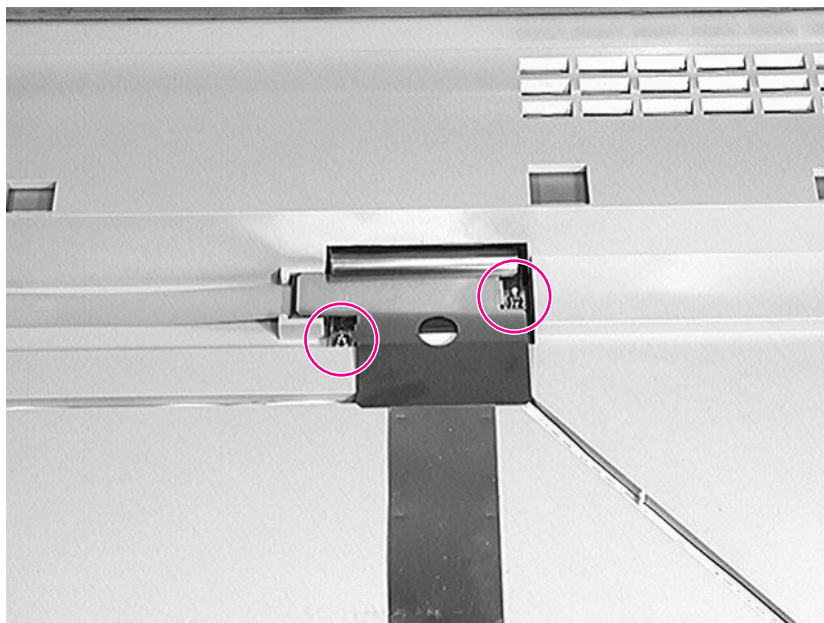

Figure 6-258 Junction PCA Cover

- 1 Remove 2 TP screws (m3x8).
- 2 Remove the Junction PCA Cover.

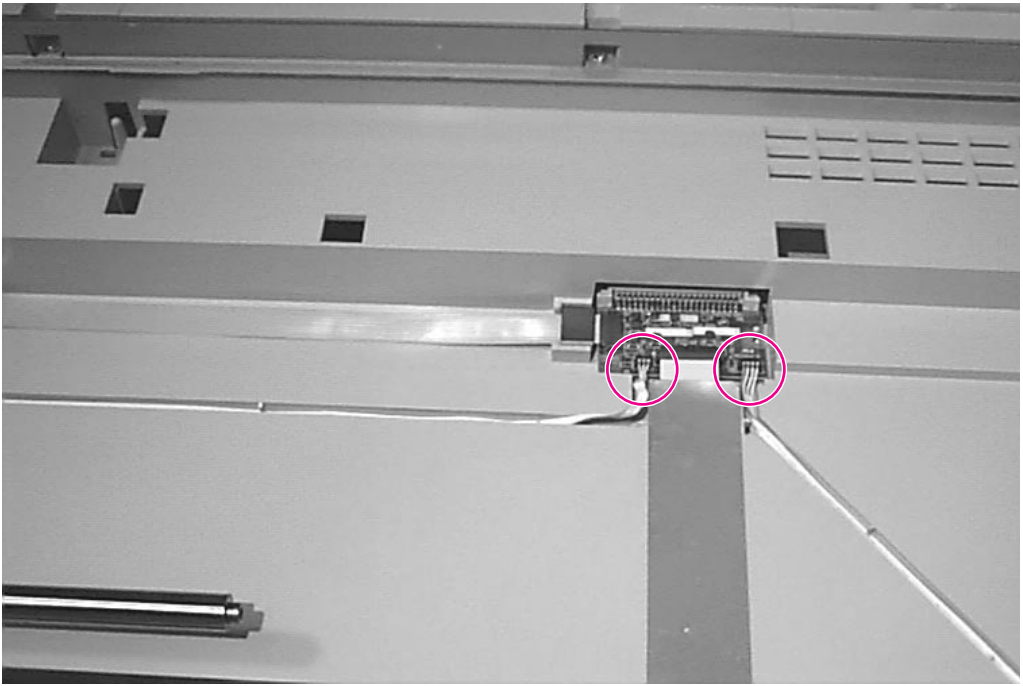

Figure 6-259 Junction PCA

3 Unplug 2 connectors.

Note For replacement, note the routing of the cables.

Front Panel Ribbon Cable

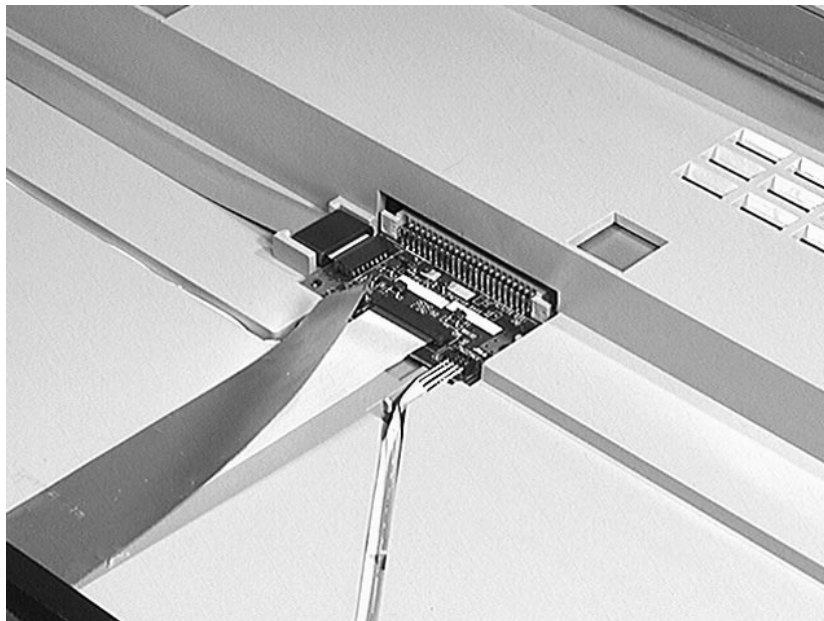

Figure 6-260 Front Panel Ribbon Cable

CAUTION

Do not bend the metal Front Panel Cable Cover.

- 1 Gently peel off one side of the Front Panel Cable Cover.

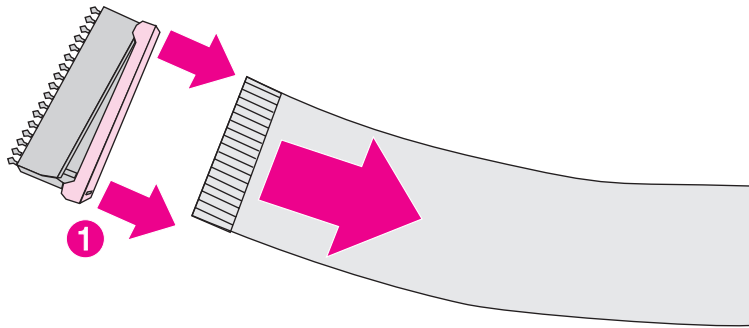

Figure 6-261 Unplugging the Ribbon Cable

- 2 Remove the Front Panel Cable Clamp and Front Panel Frame Ground Plate (figure 6-210 on page 456).
- 3 To release the Ribbon Cable, use your fingernail to gently pull up each end of the connector (callout 1). Unplug the ribbon cable. Note the orientation of the contacts on the cable so the cable is not twisted.

To replace

CAUTION

You must remove the Front Panel Cable Clamp and Front Panel Frame Ground Plate in order to replace the cable. The cable will be crushed if you place it over the top of the clear cover.

- 1 Remove the Front Panel Cable Clamp and Front Panel Frame Ground Plate.
- 2 Replace the Ribbon Cable and the Front Panel Cable Clamp and Front Panel Frame Ground Plate.
- 3 Make sure the Front Panel Cable Clamp lies as flat as possible, allowing the Carrier Unit to pass over without touching the clear part.

Carrier Belt and Motor

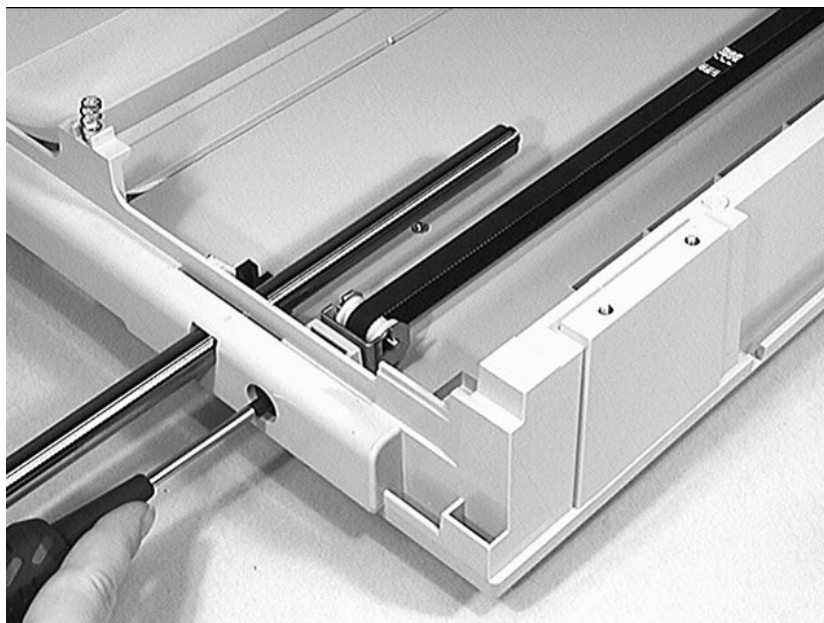

Figure 6-262 Carrier Belt and Motor (1 of 2)

- 1 Remove 1 machine screw with washer (m3x35) to release the pulley shaft and pulley spring.
- 2 Remove the Carrier Belt from the pulley.

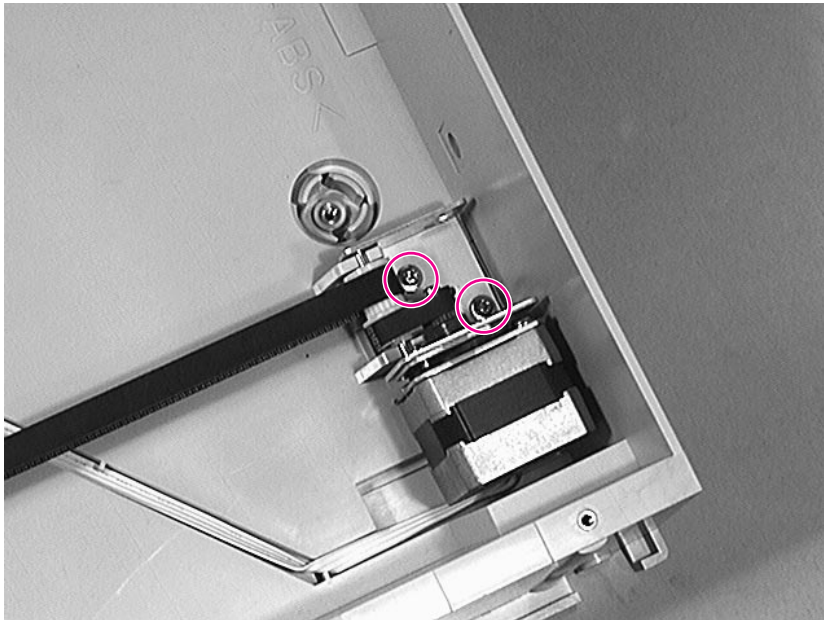

Figure 6-263 Carrier Belt and Motor (2 of 2)

CAUTION

Do not disassemble the Carrier Motor Assembly.

- 3 Remove 2 TP screws (m3x6) from the bracket by the motor.
- 4 Lift the motor and unplug 1 connector from underneath the motor.

Note

The replacement Flatbed Motor Unit includes a replacement motor, a short belt, and a long belt. The cable, pulley shaft, and spring are ordered separately.

To replace

- 1 Reverse the above procedure.
- 2 To adjust the tension of the Carrier Belt, tighten or loosen the screw shown in Figure 6-262.

7 Troubleshooting

Chapter contents

Service Approach	512
Troubleshooting Process	515
Troubleshooting the Mopier System-	522
Troubleshooting the Mopier and Paper-handling Devices	534
Step 1 Power On	534
Step 2 Display	538
Step 3 Printer and Paper-Handling Devices Messages	542
Step 4 Paper Path Troubleshooting	581
Step 5 Information Pages	587
Step 6 Image Quality	597
Self-Diagnostics on Paper-handling Devices	617
Diagrams	638
Troubleshooting the HP Digital Copy 320	651
Step 1 Power On	652
Step 2 Display and Communication	653
Step 3 Error Messages and Problems	654
Step 4 Image Quality	661
Step 5 Paper Path	660
Testing the HP Digital Copy 320	664

Service Approach

Repair of the complete Mopier system normally begins with a four-step process:

- Step 1: Isolate the problem to the major system, i.e. the host computer, the network and/or server, or the printer system. See “Mopier System Troubleshooting Process” on page 517.
- Step 2: Determine if the problem is located in the paper-handling devices or in the printer engine. See “Mopier/Paper-Handling Troubleshooting Process” on page 518.
- Step 3: Determine if the problem is located in the copy module. See “Copy Module Troubleshooting Process” on page 520.
- Step 4: Troubleshoot the problem using the procedures in this chapter.

Once a faulty part is located, repair is usually accomplished by assembly level replacement of Field Replaceable Units (FRUs). Some mechanical assemblies may be repaired at the subassembly level. Replacement of components on the printed circuit assemblies is not supported by Hewlett-Packard.

Ordering Parts

Field replaceable part numbers are listed in Chapter 8 of this manual. Replacement parts may be ordered from HP's Support Materials Organization (SMO), or Support Materials Europe (SME).

Phone numbers

PSD/SMO (Product Support Division/Support Materials Organization)

1-800-227-8164 (U.S. Only)

PSD/SME (Product Support Division/Support Materials Europe)

(49 7031) 142253

HP's Distribution Center (HPD)

1-303-353-7650

Exchange Program

HP offers remanufactured assemblies for some parts. These are identified in Chapter 8 and can be ordered through Parts Direct Ordering (PDO), Support Materials Organization (PSD/SMO), or Support Materials Europe (PSD/SME).

Consumables

The Mopier has two consumables; the toner cartridge and staple cartridges, which may be ordered directly from Hewlett-Packard. See Chapter 8 for ordering information.

Toner Cartridge Life

The Toner Cartridge is designed to simplify replacement of the major “consumable” parts. The toner cartridge contains the printing mechanism and a supply of toner.

At 5% page coverage, a toner cartridge is guaranteed to print approximately 20,000 images.

The toner cartridge may print less than 20,000 images if routinely printing very dense print. Conversely, when routinely printing images with less coverage (such as short memos), or in EconoMode, the toner cartridge may print more than 20,000 images. However, EconoMode does not extend toner cartridge component life.

Note

For best results, always use a new toner cartridge before the expiration date stamped on the toner cartridge box.

Refilled Toner Cartridges and Non-HP Staple Cartridges

While Hewlett-Packard does not prohibit the use of refilled toner cartridges and non-HP staple cartridges, their use is not supported for the following reasons:

- Hewlett-Packard has no control or process to ensure that a refilled toner cartridge or non-HP staple cartridge functions at the high level of reliability of a new HP LaserJet toner cartridge or HP LaserJet staple cartridge. Also, Hewlett-Packard cannot predict the long term reliability effect on the printer when using different toner formulations found in refilled cartridges.
- The print quality of HP LaserJet toner cartridges influences the customer's perception of the printer. Hewlett-Packard has no control over the actual print quality of a refilled toner cartridge.

Recycling Toner Cartridges

In order to reduce waste, Hewlett-Packard uses a recycling program for used toner cartridges. Cartridge components that do not wear out are recycled, as are plastics and other materials. Hewlett-Packard pays the shipping costs from the user to the recycling plant. For each cartridge returned, HP donates one U.S. dollar to be shared by the Nature Conservancy and the National Wildlife Federation. To join this recycling effort, follow the instructions inside the toner cartridge box.

Troubleshooting Process

The troubleshooting process is a systematic approach that addresses the major problems first and then other problems as you identify the causes for printer malfunctions and errors. If you know the cause of a problem in the Mopier system, go directly to that area. Otherwise, use the troubleshooting process diagrams starting on the next page. The diagrams illustrate the major steps for troubleshooting the printing system. In the diagrams starting on page 517, each heading depicts a major troubleshooting step. A **YES** answer to the questions allows you to proceed to the next major step.

A **NO** answer indicates that additional testing is needed. Proceed to the referenced location and follow the directions for that area. After completing the additional testing, proceed to the next major step.

To avoid replacing parts that are not broken, use figure 7-1 below to isolate the problem.

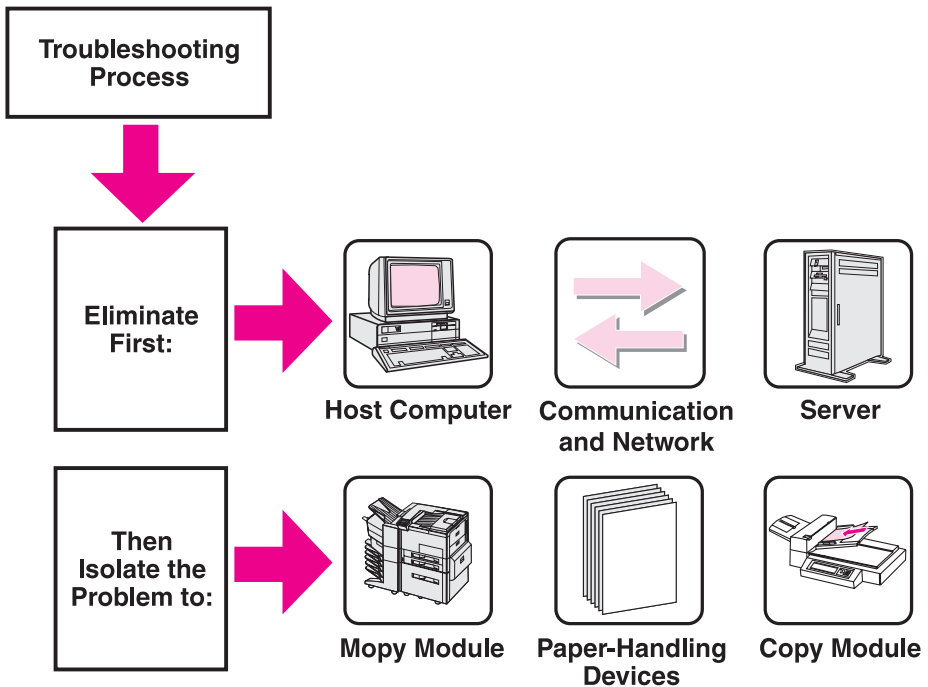

Figure 7-1 Troubleshooting Process

See the flowcharts on the following pages for each of the components of the troubleshooting process:

- Mopier System Troubleshooting Process (page 517)
- Mopier/Paper-Handling Troubleshooting Process (page 518)
- Copy Module Troubleshooting Process (page 520)

Mopier System Troubleshooting Process

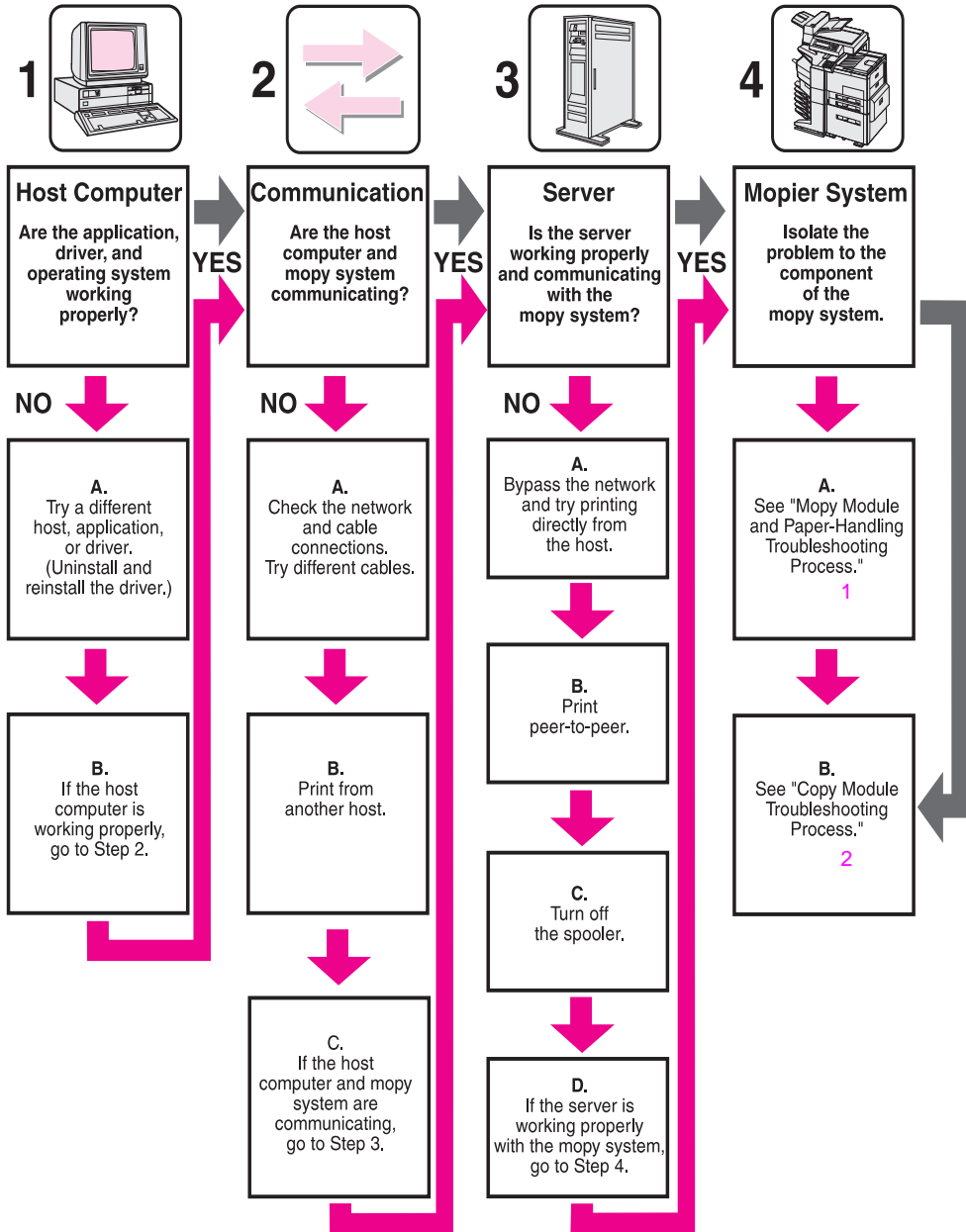

Figure 7-2 Mopier System Troubleshooting Process

- 1** Mopier/Paper-Handling Troubleshooting Process (page 518)
- 2** Copy Module Troubleshooting Process (page 520)

Mopier/Paper-Handling Troubleshooting Process

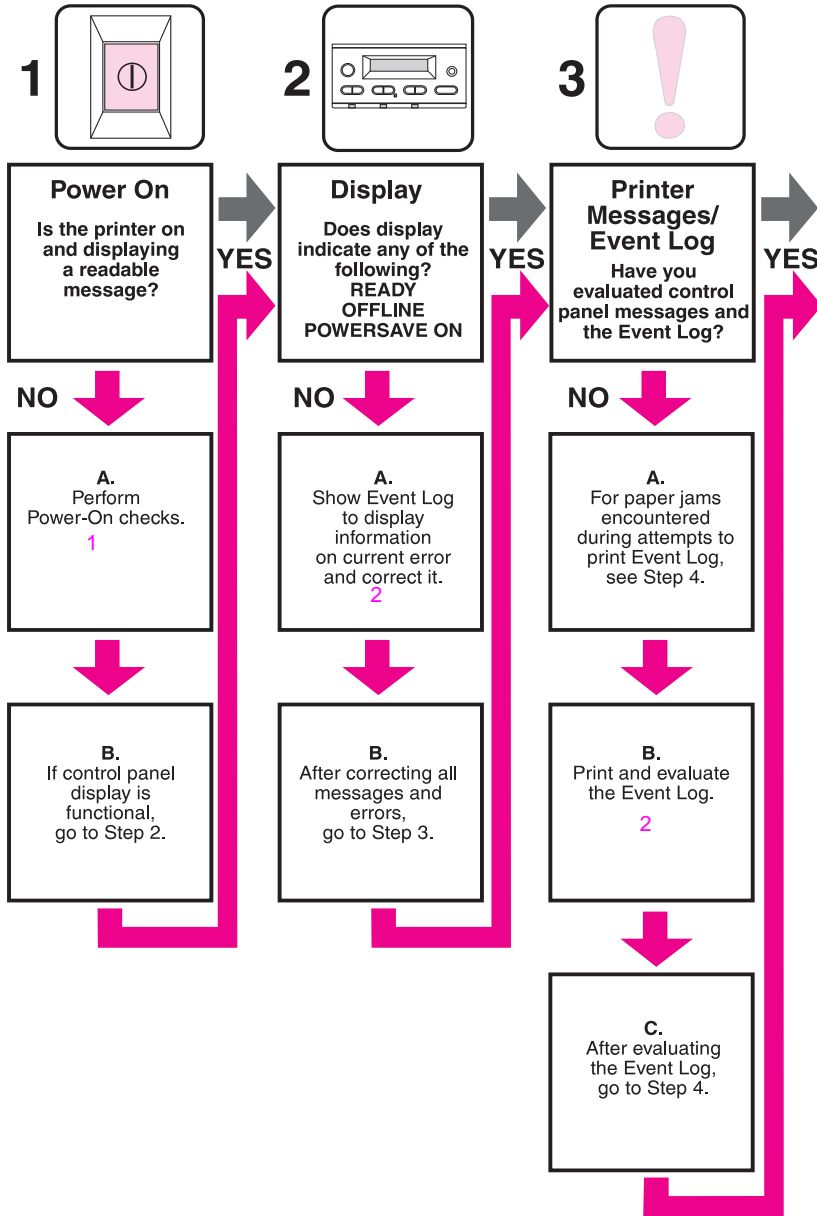

Figure 7-3 Mopier and Paper-Handling Troubleshooting Process (1 of 2)

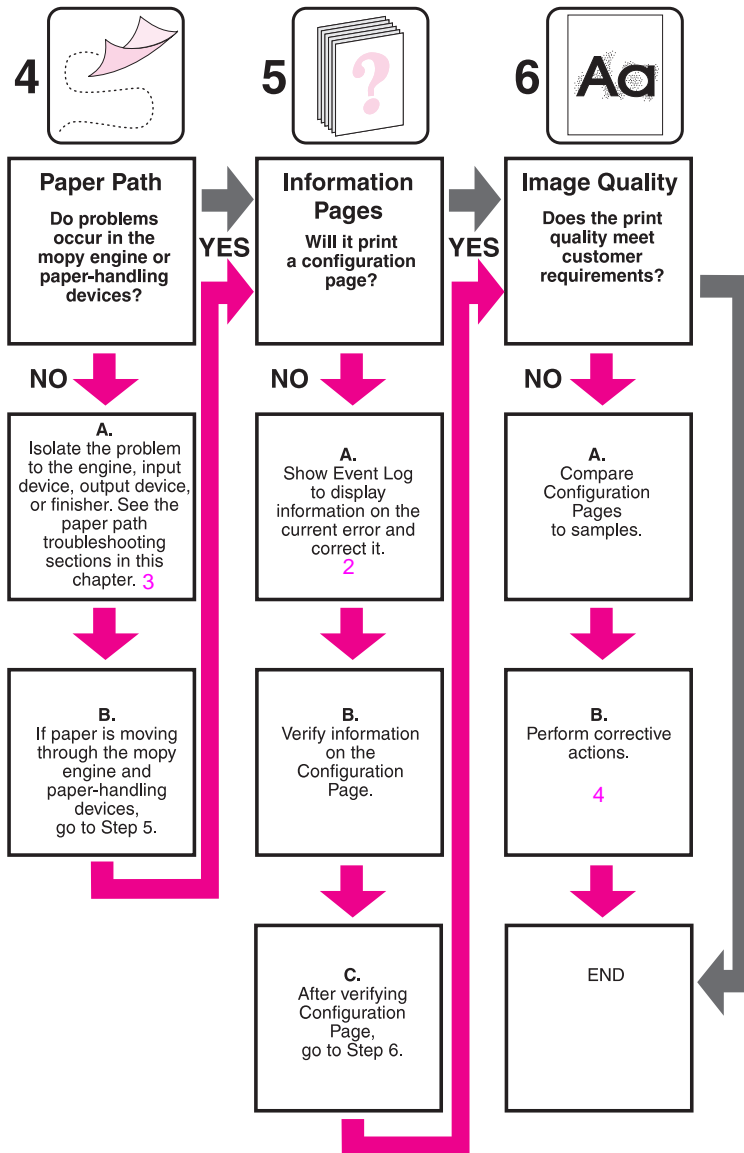

Figure 7-4 Mopier and Paper-Handling Troubleshooting Process (2 of 2)

- 1. Power On (page 534)
- 2. Event Log (page 538)

- 3. Paper Path Troubleshooting (page 581)
- 4. Image Quality (page 597)

Copy Module Troubleshooting Process

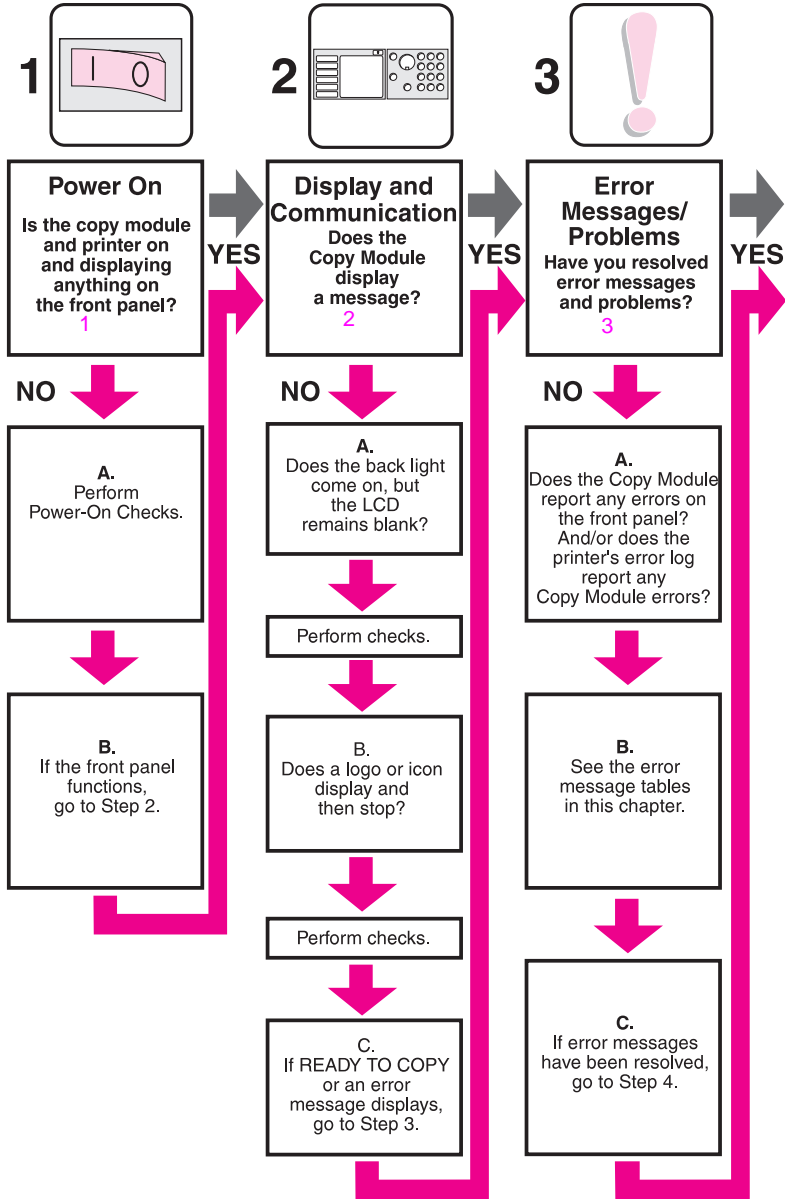

Figure 7-5 Copy Module Troubleshooting Process (1 of 2)

1. Power On (page 652)

2. Display and Communication (page 653)

3. Error Messages and Problems (page 654)

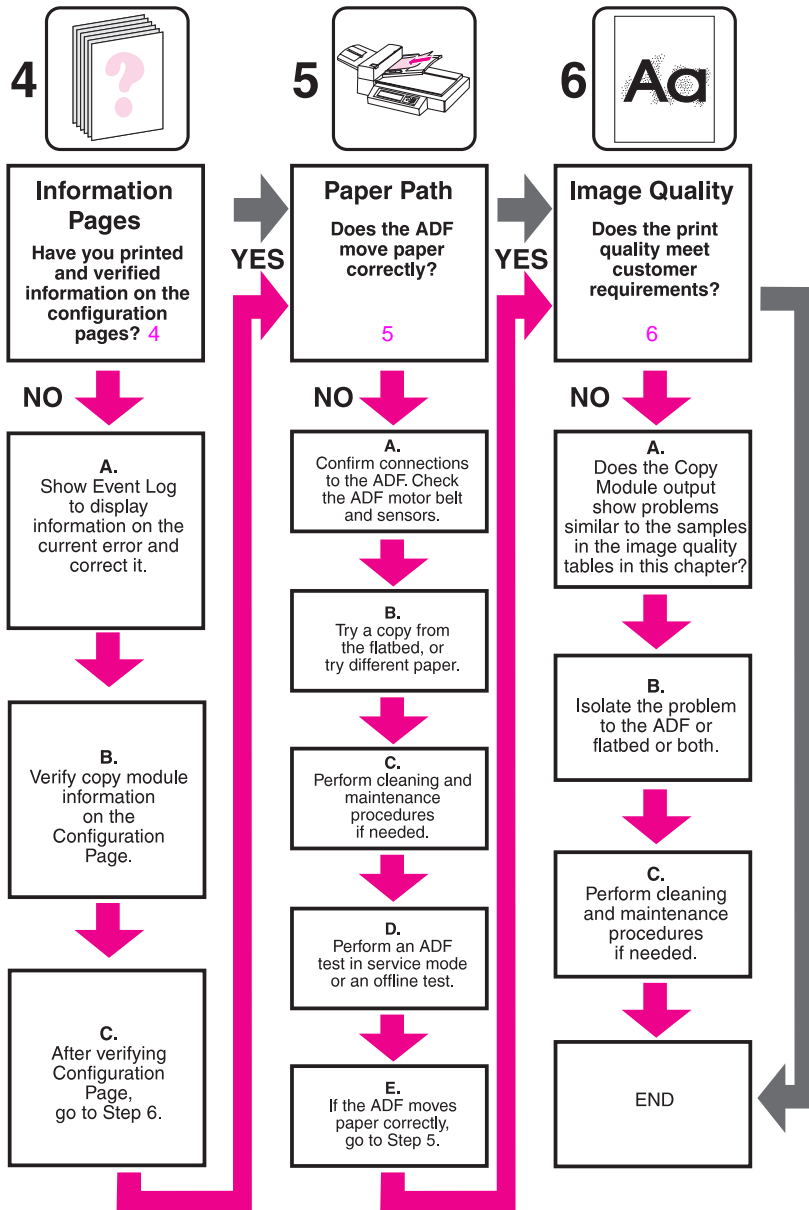

Figure 7-6 Copy Module Troubleshooting Process (2 of 2)

- 4. Information Pages (page 659)
- 5. Paper Path (page 660)

- 6. Image Quality (page 661)

Troubleshooting the Mopier System

Preliminary Operating Checks

Prior to troubleshooting a specific printer problem, you should ensure that:

- The printer is being maintained on a regular basis as described in Chapter 4.
- The customer is using acceptable paper as specified in the *HP LaserJet Printer Family Paper Specifications Guide*.
- The printer is positioned on a solid, level surface.
- The line voltage does not vary more than 10% from the nominal rated value as specified on the Power Rating Label.
- The operating environment for the printer and paper is within the temperature and humidity specifications listed in Chapter 1 of this manual.
- The printer is never exposed to ammonia fumes such as those produced by diazo copiers or office cleaning materials.
- The printer is not exposed to direct sunlight.
- Non-HP components (such as refilled Toner Cartridges, font cartridges, and memory boards) are removed from the printer.

Note

When moving the printer into a warm room from a cold location such as a warehouse, various problems can occur due to condensation in the printer. For example, if the photosensitive drum is cold, the resistance of the photoconductive layer will be high. This will lead to incorrect contrast. Leave the printer running for 10 to 20 minutes.

Communication

Ask the customer to run a print job from the host system. If the print job is successful, communication to the printer is ensured.

Interface Troubleshooting

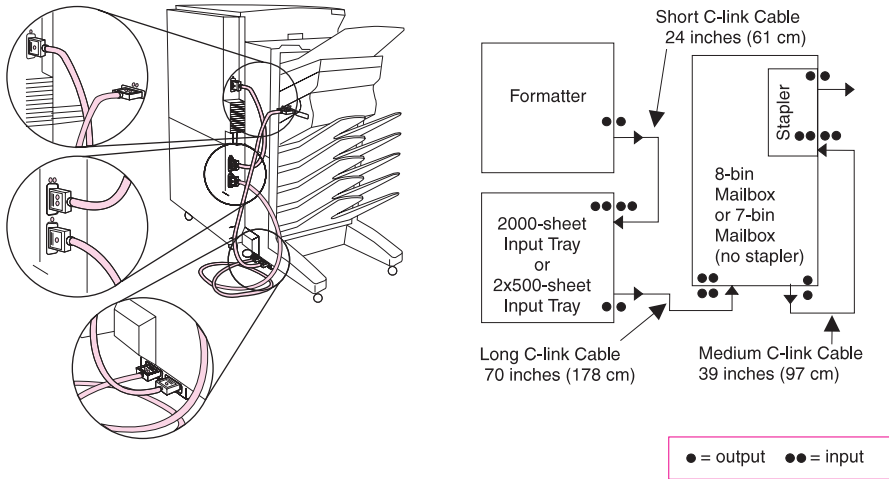

Figure 7-7 Communications Link (C-link) Cables, Supported Daisy Chain Connections

Note If the 7-bin Tabletop Mailbox is sitting on a tabletop instead of on a stand, it is the first device in the daisy chain.

All C-link cables have a single dot molded into the device output connector cable end, and two dots molded into the device input connector cable end.

Note It is important that the C-link cables are installed in the supported daisy chain configuration as shown in figure 7-7. This is so that the devices are recognized and correctly reported on the Event Log.

It is possible, but not recommended, to attach the C-link cables in other configurations. This will rearrange the supported device numbering. Keep this configuration in mind when evaluating the Event Log.

If any of the installed devices are not shown on the configuration page, verify that the C-link cabling is correctly connected and functional (figure 7-7) and that DC power is available to the paper handling devices. Check and reseal suspect cable connections. If any of the cables are replaced, you must cycle the power to have the printer recognize the device again.

Network Troubleshooting

This section provides an overview of the printer's interface requirements.

Note

Communication problems are normally the customer's responsibility. Refer the customer to the network administrator for assistance in troubleshooting network problems.

Test Message

After the printer is installed, verify communications between the printer and the IBM-compatible computer. Enter the following at the DOS prompt:

```
C:\>DIR>LPT1 ENTER (for printing to parallel port #1)
```

The printer should print a directory listing of the C:\ directory.

EIO Troubleshooting

The JetDirect Configuration Page shown in figure 7-8 on page 526 contains valuable information about the current status of the EIO accessories. Before attempting to troubleshoot a network problem or notifying your network consultant of a problem, always print a Configuration Page from the Control Panel's Information Menu. If an EIO accessory is installed, the JetDirect Configuration Page prints too.

See the *HP JetDirect Network Interface Configuration Guide* for detailed explanations of network issues.



Figure 7-8 Sample JetDirect Configuration Page

- If the EIO JetDirect Card has successfully powered up and completed its internal diagnostics, the `I/O CARD READY` message will appear. If communication is lost, an `I/O NOT READY` message appears followed by a two digit error code. Consult the *HP JetDirect Network Interface Configuration Guide* for further details and recommended action.
- The “Network Statistics” column indicates the status of network activity. Bad packets, framing errors, un-sendable packets, and collisions should be minimal. If a high percentage (greater than one percent) of these occur, contact the network administrator. All of the statistics are set to zero when the printer is powered off.
- A “Novell Status” block should state the Novell printer server name to which the printer is connected. If the Node Name reads “NPIxxxxxx” (xxxxxx = last six digits of the EIO's LAN address), the EIO card has not been configured for a Novell server (as in figure 7-8). This could indicate that the card is operating under an IPX protocol other than Novell. Consult with the network administrator if the Node Name is not present.
- In the TCP/IP protocol block, the default IP address is “192.0.0.192.” It is acceptable to operate the printer with this default address. The error message, `ARP DUPLICATE IP ADDRESS` may appear in this block. This is also an acceptable error code if the TCP/IP protocol is not being used. Please check with the network administrator to determine the correct IP address for the printer.

Verify Host System Operation

Try to print to another known working printer or move the failing printer to a known working location. Verify that the correct driver is installed and operating properly.

Verify Network and Server Operation

- Try to print the job to the printer's parallel port.
- Try to print from the host system through the network to another printer. Contact the network administrator for assistance.

General Troubleshooting Information

Miscellaneous Problems and Solutions

The following lists symptoms and typical solutions to those problems.

Abnormal noises are evident, such as grinding or chattering when main motor energized.

From the toner cartridge area:

- 1 Replace the toner cartridge.
- 2 Replace the Main Gear Assembly. See “Main Gear Assembly” on page 256 for instructions.

From Tray 2 or 3:

- 1 Verify proper paper loading, acceptable media.
- 2 Inspect the “fingers” on the paper trays to ensure proper paper size detection.
- 3 Replace the Paper Input Unit. See “Paper Input Unit (PIU)” on page 260 for instructions.
- 4 Replace the Main Gear Assembly. See “Main Gear Assembly” on page 256 for instructions.

From 2000-sheet Input Tray:

- 1 Check the white plastic bushing on Tray 4. The bushing is located on the Tray 4 main drive assembly. The bushing accepts the Tray 4 pilot pin when Tray 4 is closed. Replace if broken.
- 2 Replace 2000-sheet Input Tray Vertical Transfer Assembly.
- 3 Replace the 2000-sheet Input Tray Main Drive Assembly.

From 8-bin Mailbox:

- 1 Verify pawls are riding above the output rollers (see figure 7-24 on page 639).

Will not feed from Tray x when printing from application; paper path test works fine.

Verify the correct paper size:

- 1 Tray 1: From Control Panel Paper Handling Menu.
- 2 Tray 2, 3, 4, or 5: Remove and reseal the paper fences in the correct position in the failing tray.

Excessive Image Skew

- 1 Remove and reseal the paper fences (front fence in paper trays).
- 2 Image Skew Specifications:
 - 1 mm over 260 mm length
 - First line to leading edge 5.0 +/- 2.5 mm
 - Text Stretching 1% simplex 1.5% duplex

Envelope

- Skew 6.0 over 260 mm length
- First line on envelopes to leading edge/ left margin 15 +/- 4.5 mm

Loses Page Counts, Serial Number.

Print the Event Log and look for a 68 error with a page count of zero. Using the Event Log, take the page count shown at the top of the page and add the page count from any/all errors preceding any 68 errors. Use this number and enter it into the Control Panel from Service Mode.

Will not print from 2000-sheet Input Tray or 2 x 500-sheet Input Tray.

- 1 Print the Configuration Page. Make sure that the Paper Handling Controller and 2000-sheet or 2 x 500-sheet Input Tray are listed in the Paper Handling Options section.
- 2 Verify that power is supplied to the 2000-sheet or 2 x 500-sheet Input Tray.

- 3 Run a paper path test from Tray 4 or 5. If the test is successful, the paper size detection switches may have failed or an incorrect size is specified in the application software.
- 4 Replace the Paper Handling Controller if it is not shown on the Configuration Page.
- 5 Verify that the C-link cables are connected as shown in figure 7-7 on page 523.
- 6 Reseat the C-link Cable, and inspect for pushed in pins.
- 7 Replace the C-link Cable.
- 8 Replace the 2000-sheet or 2 x 500-sheet Input Tray Controller PCA.

Jams when printing envelopes, transparencies, or labels to the 8-bin Mailbox or 5-bin Mailbox with Stapler.

The 8-bin Mailbox does not support these media. Direct these media to the Face-up Bin (top bin of the 8-bin Mailbox).

Stops printing and hangs on certain jobs.

- 1 Remove any non-HP Memory DIMMs and retry.
- 2 Set to 300 DPI and retry.

Top 2/3 of portrait page is lighter.

- 1 Replace the Toner Cartridge and retry.
- 2 Replace the Transfer Guide.

Will not print to Mailbox.

- 1 Print the Configuration Page. Make sure that the Paper Handling Controller, 2000-sheet Input Tray, and 8-bin Mailbox are listed in the Paper Handling Options section.
- 2 Replace the Paper Handling Controller if it is not shown on the Configuration Page.
- 3 Inspect the C-link Cables for pushed out pins.
- 4 Replace the C-link Cables.
- 5 Connect the 8-bin Mailbox directly to the printer. If it is now recognized on the Configuration Page, replace the 2000-sheet Input Tray Controller.
- 6 Replace the 8-bin Mailbox Controller.
- 7 Replace the 8-bin Mailbox External Power Supply.
- 8 Replace the entire 8-bin Mailbox.

Wrinkling Envelopes

- 1 Place the Fusing Levers in up position and retry the envelopes.
- 2 Try new media. Make sure that the envelopes are within specifications. See the *HP LaserJet Family Paper Specifications Guide*.

Poor Fusing

- 1 Make sure that the Fusing Levers are in the down position for cut sheet paper.
- 2 Try new media. Make sure that the media is within specifications. See the *HP LaserJet Family Paper Specifications Guide*.
- 3 Make sure that the AC power does not fluctuate out of range during the print cycle. See table 2-4 on page 53.

Feeds from incorrect tray when selecting different media for the first page of the job.

First you must determine if it is a hardware or a software issue. Run a paper path test from each paper tray to eliminate the hardware. See page 584.

If the paper path test fails, troubleshoot the error message.

Make sure that the most current printer driver is installed. Select the **Print Quality Tab** from the printer driver. Click on **About**. You may find the most current driver in various electronic locations. Check with HP Service and Support.

If the paper path test works, it may be a software or user related issue. Perform the following steps:

- 1 Define the media types that are loaded in each paper tray. This can be done from either JetAdmin or the front control panel of the printer.

From JetAdmin

- 1 Select the Trays tab.
- 2 Select the correct media type for each tray listed.
- 3 Click on **OK** save your changes and exit JetAdmin.

From the Control Panel

Note

To set the paper type for Tray 1, set `TRAY 1 MODE=CASSETTE` from the Paper Handling Menu.

- 1 From the Paper Handling Menu, press **ITEM** to select a specific tray.
- 2 Press **+** until you get to the correct type of media.
- 3 Press **SELECT**.
- 4 Repeat this step for each paper tray.
- 5 Press **Go**.
- 6 From inside your application, choose the page setup option for that application.
- 7 Select the paper source/type option.
- 8 Select the correct media source/type for the first page.
- 9 Select the correct media source/type for all other pages.

Note

You must have the HP Mopier 320 selected in your application in order for your application to provide you with the correct paper tray and media type selections.

CAUTION

Do not make changes to the driver unless the application does not provide this option. Print job settings selected through your application always override settings made through the printer driver. Printer settings made in the application or print driver always override the corresponding setting made on the printer Control Panel.

- 10 Print the document.

Paper Curl

Paper curl is inherent to the laser printing processes, as it occurs when paper is subjected to heat. Paper curl tends to relax as the paper cools while resting on a flat surface. The specification for maximum paper curl when the paper is lying flat before print is 0.2 inches (5 mm).

Although paper curl cannot be totally eliminated, some steps can be taken to lessen its impact, as suggested in the following table.

Table 7-1. Paper Curl

Possible Cause	Recommended Action
1. Paper Path	Try using Tray 1 and output the paper to the Face-up Bin.
2. Paper Surface	The recommended printing surface of the page is usually marked on the end of a ream of paper, indicated by a small arrow and the phrase "print this side first." Load paper in Tray 1 with the recommended printing surface facing up (facing down in Trays 2, 3, 4, and 5).
3. Paper Storing and Handling	Over time, paper assumes the characteristics of its storage environment (in a humid environment, paper absorbs moisture; in a dry environment, paper loses moisture). Paper with higher moisture content will tend to curl more. Evaluate the storage conditions of the paper.
4. Paper Type	All paper is manufactured differently (different textures, moisture content, drying processes, composition, etc.). Change the type of paper being used and re-evaluate the paper curl results.

Troubleshooting the Mopier and Paper-handling Devices

Step 1 Power On

It is important to have the printer's Control Panel functional as soon as possible in the troubleshooting process so that the printer's diagnostics can assist in locating printer errors.

Table 7-2. Power On Defects or Blank Display

Problem	Action
1. Is AC power available at the printer's power receptacle?	Verify. See table 2-4 on page 53.
2. Is the printer's on/off switch set to on?	Push the switch to the on position.
3. Are the printer's fans on? (See figure 7-9 on page 536 to locate the fans.)	Note: Fan operation is significant since all fans are controlled by the printer's DC Controller PCA. When the printer is in PowerSave mode, the fans are off. Make sure that the printer is not in PowerSave mode. Press Go . Operational fans indicate: <ol style="list-style-type: none">1. AC power is present in the printer.2. DC power supply is functional (both 24V DC and 5V DC are being generated).3. DC Controller PCA's micro-processor is functional.
NO	If the fans are NOT working, turn off the printer and remove the printer's Formatter PCA. Disconnect all the printer's paper handling options. Then turn on the printer and check the fans again. If the fans are still not working, perform the following steps: <ol style="list-style-type: none">1. Verify that all fans are connected to the DC Controller PCA according to figure 7-29 on page 644.2. Replace the low-voltage DC power supply. See "Low Voltage Power Supply (LVPS)" on page 270 for instructions.3. Replace the DC Controller PCA. See "PCA, DC Controller" on page 261 for instructions.

Table 7-2. Power On Defects or Blank Display (continued)

Problem	Action
YES	<p>If the fans are working but the printer's Control Panel is blank, print an engine test. See "Engine Test" on page 537.</p> <p>If the engine test was successful, perform the following steps:</p> <ol style="list-style-type: none">1. Reseat or replace the cable from the Control Panel that is connected to J203 of the DC Controller PCA (see the main wiring diagram in the back of the manual).2. Replace the printer's Formatter PCA. See "Formatter Assembly" on page 250 for instructions.3. Replace the Control Panel assembly. See "Control Panel" on page 215 for instructions. <p>If the engine test was not successful, verify that there is no paper in the paper path. Retry the engine test. If the engine test is still unsuccessful, replace the DC Controller PCA. See "PCA, DC Controller" on page 261 for instructions.</p> <hr/>

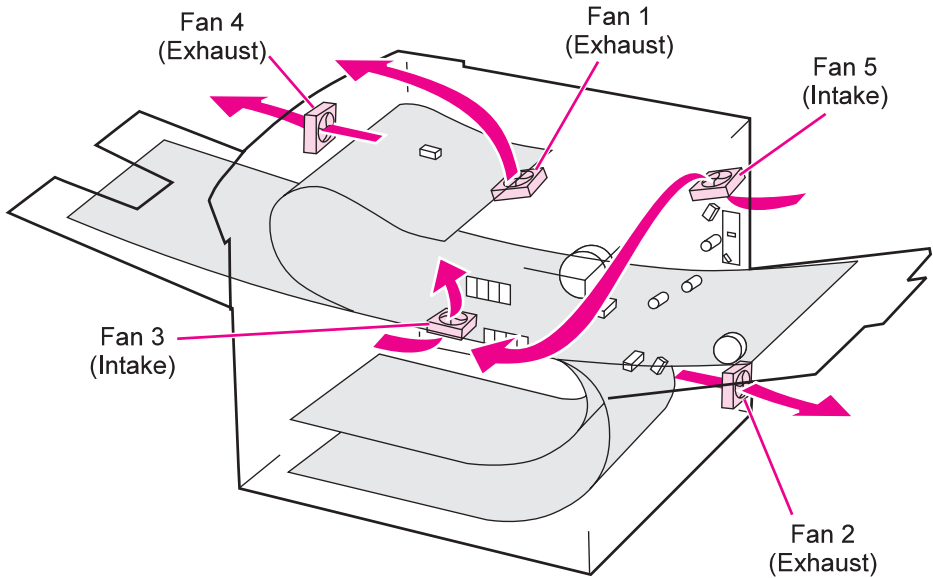

Figure 7-9 Fan Location and Airflow

Table 7-3. Fans

Fan Name	Fan Location
Fan 1: Laser/Scanner Fan	Exhaust air flows from the back of the printer, on the left-hand side of the fusing assembly.
Fan 2: Low-voltage Power Supply Fan	Lower right-hand corner of the printer.
Fan 3: Formatter Fan (intake)	Intake fan below the formatter.
Fan 4: Standard Output Delivery Fan	Directly above the center of the fusing assembly.
Fan 5: MP Tray (Intake) Fan	Right side of MP (Tray 1) Assembly

Note Control Panel numbers do not correspond to fan numbers (i.e., a fan error ending in .1 does NOT refer to Fan 1).

Engine Test

The engine test verifies that the print engine is functioning correctly. This test is very useful for isolating printer problems since the Formatter PCA is completely bypassed during an engine test. The engine test prints a full page of horizontal lines across the entire printable area. The engine test prints from Tray 3 ONLY and can be activated with the Formatter PCA removed.

Note

Tray 3 **must** be installed and loaded with paper to perform an engine test. Also, make sure that the EP toner cartridge is installed in the printer.

Engine Test Button Location

The engine test button is located on the DC Controller PCA. It is accessible through a hole at the right rear of the printer. See figure 7-10.

Printing an Engine Test

To print an engine test, use a non-metallic object (such as a pencil) to press the engine test button (see figure 7-10). A single test page will print. The engine test will be continuous as long as the button is held in.

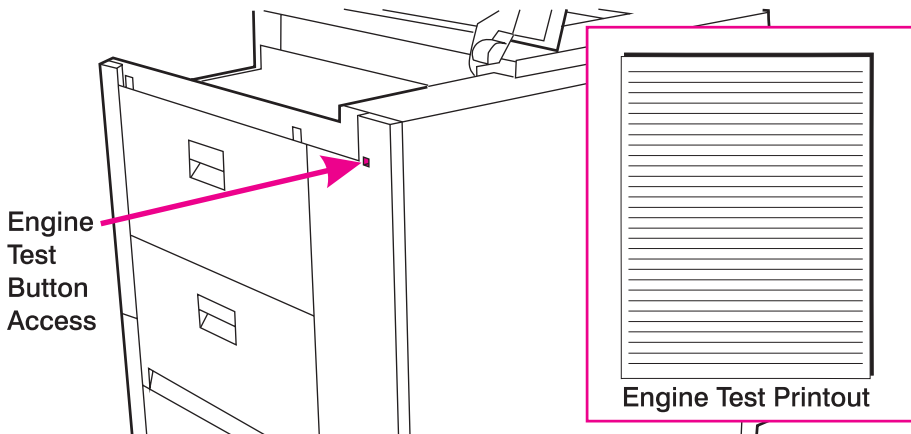

Figure 7-10 Engine Test Button

Step 2 Display

The Control Panel should display `READY`, `OFFLINE`, or `POWERSAVE ON`. For information about errors displayed, access the Event Log. If the display is blank, see “Power On Defects or Blank Display” on page 534.

Event Log

Use the Event Log to diagnose and troubleshoot printer errors and intermittent failures. You can either print or display the Event Log from the Control Panel’s Information Menu. (Select `PRINT EVENT LOG` or `SHOW EVENT LOG`.) (The Configuration Page lists the maximum number of entries in the Event Log.)

See figure 7-11 on page 539 for a sample Event Log. The Event Log shows the current page count at the left side of the page, with the printer’s serial number directly to the right of the page count. The left column is the error sequence number, with the error listed on the right (the highest sequence number is the most recent event logged). The next column is the page count at the time of the error, and the last column is the Personality (PCL or PostScript) column or the Jam Cause at the time of the error.

See “Printer Message Tables” on page 544 for more information about correcting Event Log messages in the printer and paper handling devices.

Display the Event Log

If the printer cannot print or move any paper, follow these steps to display the Event Log. Otherwise, print the Event Log.

1. Press **Menu** until INFORMATION MENU appears.
2. Press **Item** until SHOW EVENT LOG appears. Press **Select** to show the Event Log.
3. Press **- Value +** to scroll through the Event Log.
4. Write down the error messages. For example:

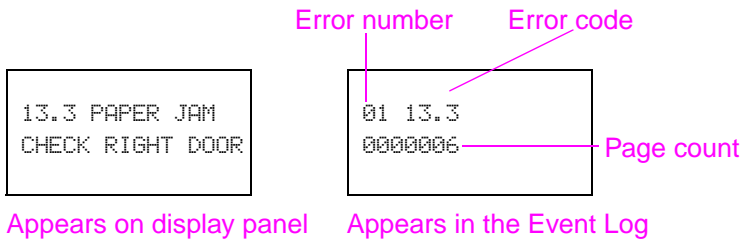

5. Check the Event Log for specific error trends in the last 10,000 printed pages.
6. Ask the customer for any observed error trends. (For example, do paper jams tend to occur in a specific area of the printer?)
7. Record any specific error trends.
8. See "Printer Message Tables" on page 544 and follow the recommended action.
9. If the Control Panel displays **READY**, **OFFLINE**, or **POWERSAVE ON**, go to the next section. If it displays any other message, repeat this procedure starting from step 1.

Interpret the Event Log

See figure 7-11 on page 539 for a sample Event Log.

The errors on the control panel and the Event Log codes may not be the same. For example, 13.11 on the control panel may be 13.11 1B in the Event Log. The 1B provides more information about the error. Likewise, if a 50.1 FUSER ERROR is displayed on the Control Panel, the Event Log will record a 50.02.01 error, with the 02 signifying that 2 sensors were blocked. Make sure that you refer to the correct number in “Printer Message Tables” on page 544.

When an error is detected in an Optional Paper Handling Device, a 13.11, 11.zz, 22.zz to 13.12,13.22, or 66.xx.zz will be displayed on the Control Panel.

Hint

Whenever a 13.xx appears on the Control Panel, a good practice is to clear the jammed paper from the printer, press **Go** to take the printer offline, and print the Event Log. If you cannot print the Event Log, you can still display it on the Control Panel. The last error is the error at the top of the Event Log printout with the highest number in the left-most column. Write the error next to the last error logged.

To interpret the Event Log:

- Each individual entry in the log is called an “error,” while all errors occurring at the same page count are called an “event.” See the Recommended Action in “Printer Message Tables” on page 544 for each error comprising an event to gain a clear picture of what took place during that event. Events usually conclude with a time-out or no response from the device (error 66.xx in the Event Log). Turn the printer off, and then turn the printer on.
- Use the Event Log table in this section to associate errors in the Event Log with the Control Panel error message. Follow the Recommended Action listed in the Event Log Table starting on page 544 for each error or event.

Note

It is assumed that any Paper Handling Devices are connected as shown in the C-link Cable Diagram (figure 7-7 on page 523). The errors will be logged with different device numbers if any non-standard cabling is installed.

Step 3 Printer and Paper-Handling Devices Messages

Be sure to read the exact text of the control panel message, including the error message number and the text, in order to locate the error message in the tables.

This printer has enhanced information in the control panel.

Printer messages displayed on the control panel provide five categories of information. Each message category is assigned a priority. If more than one condition occurs at the same time, the highest priority message is displayed. When it has been cleared, the next priority message will be displayed, and so on. The displayed messages and their priorities are:

- Printer Status
- Warning messages
- Error messages
- Critical error messages
- External Paper Handling Device Messages

Control Panel and Event Log Message Format

The format of Control Panel messages is:

- 13.x9 PAPER JAM IN INPUT/OUTPUT DEVICE
- INPUT/OUTPUT DEVICE CONDITION x9.zz
- 66.x9.zz INPUT/OUTPUT DEVICE FAILURE

The Event Log messages have the following format:

- 13.x9 zz INPUT/OUTPUT DEVICE PAPER JAM
- 65.x9.zz INPUT/OUTPUT DEVICE CONDITION
- 66.x9.zz INPUT/OUTPUT DEVICE HARDWARE MALFUNCTION

Note

The following are two examples of Control Panel messages, the corresponding Event Log messages, and what the messages mean. These examples do not show the recommended action to follow to fix the problem. See “Printer Message Tables” on page 544 for the recommended actions for these messages.

Control Panel Message	Event Log Page	Meaning
13.11 PAPER JAM IN INPUT DEVICE	13.11 1B	A paper jam occurred in the first C-link device configured. It is an input device (2000-sheet Input Tray or 2 x 500-sheet Input Tray) with an error code 1B. This is normally a timeout at an entry or exit sensor.
66.22.09 OUTPUT DEVICE FAILURE	66.22.09	A hardware malfunction occurred in the second C-link device configured. It is an output device (Mailbox) with an error code 09. This is an external memory error.

Note Be sure to print a configuration page to properly identify the input or output device configured. Notice that the error format only identifies the C-link device number and the device type; it does not identify which input or output device is used in the system.

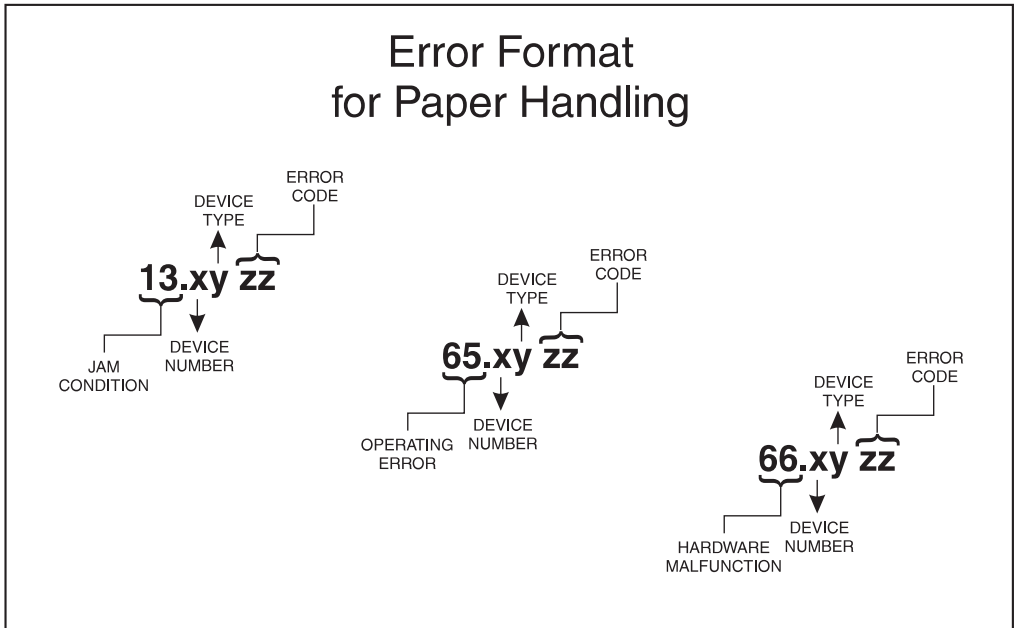

Figure 7-12 Error Format for Paper Handling

Printer Message Tables

Printer messages are grouped according to the device generating the error. Within the groupings listed below, the alphabetic error messages are listed first, followed by the numeric messages.

- “Engine Error Messages” (page 545)
- “Duplexer Error Messages” (page 579)

Input Devices

- “Envelope Feeder Error Messages” (page 564)
- “2000-sheet Input Tray Error Messages” (page 557)
- “2 x 500-sheet Input Tray Error Messages” (page 561)

Output Devices

- “7-bin Tabletop Mailbox Error Messages” (page 565)
- “8-bin Mailbox Error Messages” (page 570)

- “Stapler Error Messages” (page 576)
- “Paper Handling Device Controller Messages” (page 580)

The following is an example of the format for numerical control panel messages.

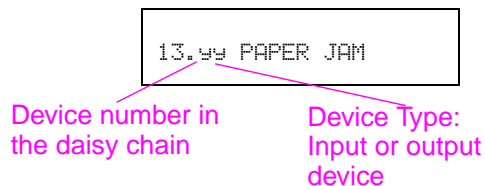

Engine Error Messages

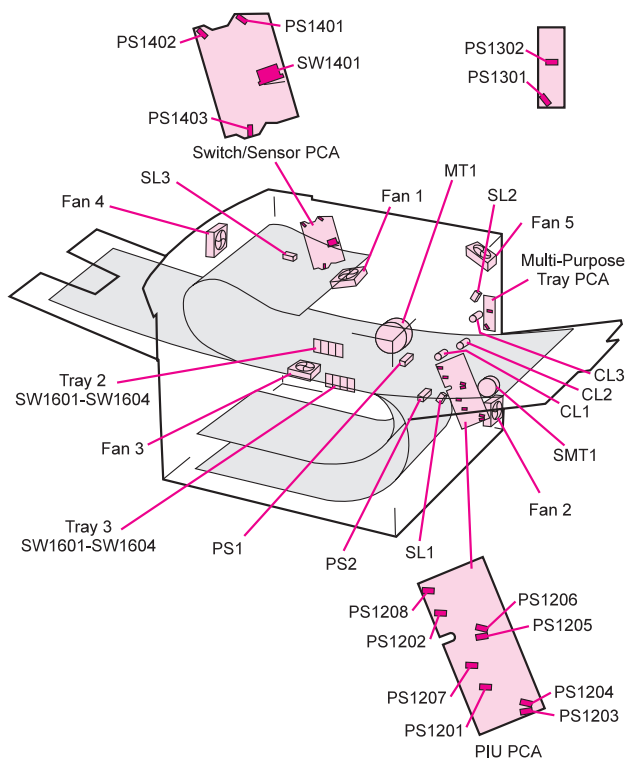

Table 7-4. Engine Error Messages

Control Panel Message	Event Log Error Message	Description	Recommended Action
13.1 PAPER JAM CHECK RIGHT DOOR	13.1 zz	Paper feed 1. Paper late jam. Paper did not reach PS2.	Use the "Paper Path Test" on page 89 to see if a problem exists from both engine trays. If PS2 is bad, it will fail when printing from Tray 2 or 3. Verify flag movement by manually inserting paper in the sensor path. Replace PS2 or the Paper Input Unit (PIU) Assembly. See "Paper Input Unit (PIU)" on page 260 for instructions.

Table 7-4. Engine Error Messages (continued)

Control Panel Message	Event Log Error Message	Description	Recommended Action
13.3 PAPER JAM CHECK RIGHT DOOR alternates with THEN OPEN AND CLOSE TOP COVER	13.3 XX	Paper delay jam. Paper did not reach PS1 at the registration area.	1. Remove the toner cartridge, lift the green handle, and verify the sensor flag operation. 2. Make sure that the sensor is not broken. 3. Replace the registration assembly if necessary. See "Registration Assembly" on page 271 for instructions.
13.5 FUSER OUTPUT, PAPER STOPPED JAM	13.5 XX	Fuser output, paper late jam. Paper never reached PS1403 at the fusing assembly.	Remove the toner cartridge, and check the path between the registration and fusing assemblies. PS1403 on the sensor PCA may be faulty.
13.6 FUSER OUTPUT PAPER STOPPED JAM	13.6 XX	PS1402 did not sense the paper. Fuser output, paper stopped jam. Paper never exited the fusing assembly.	1. Check the fuser flag at the sensor board area. 2. Check the fuser access door. 3. Make sure that the flag is not broken. PS1403 on the sensor PCA, or the delivery exit spring gears, may be faulty.
13.9 CHECK LEFT DOOR	13.9 XX	Face-down bin paper late jam.	Paper did not arrive at PS1402 when expected. Inspect the path between the fuser and delivery assemblies. Check the diverter assembly.
13.20 PAPER JAM CHECK ...	13.20 XX	The engine could not eject a page in the printer. The front panel message (...) will indicate the sensor closest to the paper.	Remove the jam from the location indicated on the control panel.
13.A PAPER JAM CHECK LEFT DOOR	13.A XX	Paper stopped at the Face-down bin.	Check the paper path. This jam is sensed by PS1402 on the sensor PCA.
20 INSUFFICIENT MEMORY alternates with PRESS GO TO CONTINUE	Error	The printer received more data than can fit in its available memory. You might have tried to transfer too many macros, soft fonts, or complex graphics.	1. Press Go to print the transferred data (some data might be lost). 2. Simplify the print job, or install additional memory.

Table 7-4. Engine Error Messages (continued)

Control Panel Message	Event Log Error Message	Description	Recommended Action
21 PAGE TOO COMPLEX alternates with PRESS GO TO CONTINUE	Error	The data (dense text, rules, raster or vector graphics) sent to the printer was too complex.	<ol style="list-style-type: none"> 1. Press Go to print the transferred data. (Some data might be lost.) 2. To print the job without losing data, from the Configuration Menu in the printer control panel, set PAGE PROTECT=ON, print the job, and then return to PAGE PROTECT=AUTO. Do not leave PAGE PROTECT=ON; it might degrade performance. If this message appears often, simplify the print job.
22 EIO x BUFFER OVERFLOW alternates with PRESS GO TO CONTINUE	Error	Too much data was sent to the EIO card in the specified slot (x). An improper communications protocol may be in use.	<ol style="list-style-type: none"> 1. Press Go to clear the message. (Data will be lost.) 2. Check the host configuration.
22 PARALLEL I/O BUFFER OVERFLOW alternates with PRESS GO TO CONTINUE	Error	Too much data was sent to the parallel port. This error can occur if the driver you are using is not IEEE-1284 compliant. For best results, use an HP driver that came with the printer.	<ol style="list-style-type: none"> 1. Check for a loose cable connection and be sure to use a high-quality cable. (Some non-HP parallel cables might be missing pin connections or might otherwise not conform to the IEEE-1284 specification.) This error can occur if the driver you are using is not IEEE-1284 compliant. For best results, use an HP driver that came with the printer. 2. Press Go to clear the error message. (Data will be lost.)
22 SERIAL I/O BUFFER OVERFLOW alternates with PRESS GO TO CONTINUE	Error	Too much data was sent to the serial port.	<ol style="list-style-type: none"> 1. Make sure that the correct serial pacing option is selected from the I/O Menu in the printer's control panel. 2. Print a Menu Map, and verify that the serial pacing item (from the I/O Menu in the printer's control panel) matches the setting on the computer. 3. Press Go to clear the error message. (Data will be lost.)

Table 7-4. Engine Error Messages (continued)

Control Panel Message	Event Log Error Message	Description	Recommended Action
40 BAD SERIAL TRANSMISSION alternates with PRESS GO TO CONTINUE	Error	<p>The printer encountered an error while transferring data from the computer. The error might have occurred for several reasons:</p> <ul style="list-style-type: none"> • The computer was powered on or off while the printer was online. • The printer's serial configuration was not the same as the computer's. 	<ol style="list-style-type: none"> 1. Verify the cable connections. Make sure that the printer's serial configuration is set the same as the computer from the I/O Menu in the printer's control panel. 2. The serial baud rate setting can be accessed from the I/O Menu in the printer's control panel. 3. Press Go to clear the error message and continue the printing. 4. Turn the printer off. 5. Reseat the EIO card, and turn the printer on.
40 EIO x BAD TRANSMISSION alternates with PRESS GO TO CONTINUE	Error	<p>The connection has been broken between the printer and the EIO card in the specified slot.</p>	<ol style="list-style-type: none"> 1. Turn the printer off, and reseat the card. 2. Press Go to clear the error message and continue printing.
41.x PRINTER ERROR alternates with PRESS GO TO CONTINUE	Error	<p>A temporary printing error occurred.</p> <p>X Description</p> <ol style="list-style-type: none"> 1 Unknown misprint error. 2 Beam detect misprint error. 3 See error 41.3. 4 No VSYNC error. 5 Media feed error. 9 Noise VSREQ error. 	<p>Press Go. The page containing the error will automatically be reprinted.</p> <p>If this message persists:</p> <ol style="list-style-type: none"> 1. Reseat the connections to the Laser/Scanner and the Engine Controller Board. 2. Replace the Laser/Scanner. See "Laser/Scanner Assembly" on page 254 for instructions. 3. Replace the Engine Controller Board.
41.3 UNEXPECTED PAPER SIZE	Error	<p>The paper size you are trying to print is not the same as the control panel setting for Tray 1.</p>	<ol style="list-style-type: none"> 1. Make sure that the control panel setting for Tray 1 or the Envelope Feeder is correctly adjusted for size. (The printer will continue trying to print the job until the size settings are correct.) 2. Press Go. The page containing the error will automatically be reprinted. (Or, you might want to press CANCEL JOB to clear the job from the printer's memory.)

Table 7-4. Engine Error Messages (continued)

Control Panel Message	Event Log Error Message	Description	Recommended Action
50.x FUSER ERROR	Critical Error	<p>A fuser error has occurred.</p> <p>X Description</p> <ol style="list-style-type: none"> 1 Low Fuser temperature. 2 Fuser warm up service. 3 High Fuser temperature. 4 Faulty Fuser. 5 Inconsistent Fuser. 	<p>Turn the printer off for at least 20 minutes, and then turn the printer on.</p> <p>If the error continues:</p> <ol style="list-style-type: none"> 1. Make sure that the Fusing Assembly is installed correctly and is fully seated into its connectors (no bent pins or pins outside their receptacles). 2. Reseat or replace the fuser cable assembly. 3. Replace the DC Controller.
51.x PRINTER ERROR	Error	<p>A temporary printing error occurred.</p> <p>X Description</p> <ol style="list-style-type: none"> 1 Beam detect error. 2 Laser error. 	<ol style="list-style-type: none"> 1. Press Go. The page containing the error will automatically be reprinted. 2. Turn the printer off, and then turn the printer on. 3. Reseat the cables. See the wiring diagrams at the back of this manual. 4. Replace the Laser/Scanner. See “Laser/Scanner Assembly” on page 254 for instructions.
52.x PRINTER ERROR	Error	<p>A temporary printing error occurred.</p> <p>X Description</p> <ol style="list-style-type: none"> 0 Laser/scanner error. 1 Laser/scanner startup error. 2 Laser/scanner rotation error. 	<ol style="list-style-type: none"> 1. Press Go. The page containing the error will automatically be reprinted. 2. Turn the printer off, and then turn the printer on. 3. Reseat the cables. See the wiring diagrams at the back of this manual. 4. Replace the Laser/Scanner. See “Laser/Scanner Assembly” on page 254 for instructions.

Table 7-4. Engine Error Messages (continued)

Control Panel Message	Event Log Error Message	Description	Recommended Action
53. x _y .zz PRINTER ERROR	Critical Error	<p>There is a problem with the printer's memory. The DIMM that caused the error will not be used. Values of x, y, and zz are as follows:</p> <p>x = DIMM type 0 = ROM 1 = RAM</p> <p>y = Device location 0 = Internal memory (ROM or RAM) 1 to 3 = DIMM slots 1, 2, or 3</p> <p>zz = Error number 0 = Unsupported memory (for example, presence detect bad) 1 = Unrecognized memory (for example, presence detect bad) 2 = Unsupported memory size 3 = Failed RAM test 4 = Exceeded maximum RAM size 5 = Exceeded maximum ROM size 6 = Invalid DIMM speed 7 = DIMM reporting information incorrectly 8 = DIMM RAM parity error 9 = ROM needs to be mapped to an unsupported address 10 = DIMM address conflict 11 = PDC XROM out of bounds 12 = Unable to make a temporary mapping</p>	<ol style="list-style-type: none"> 1. Turn the printer off, and reset or replace the specified DIMM. 2. Try the DIMM in another slot. 3. Replace the DIMM that caused the error.

Table 7-4. Engine Error Messages (continued)

Control Panel Message	Event Log Error Message	Description	Recommended Action
55.x PRINTER ERROR alternates with PRESS GO TO CONTINUE	Error	A printer error has occurred. X Description 0 NO_RESET_REPORT 1 NO_ENGINE_RESPONSE 2 EXCESSIVE_GLITCHES 3 LOST_PPRDY_SIGNAL 4 COMMUNICATION_TIMEOUT 5 BAD_TRAY_BIN_REPORTS 6 ECC7_COMMAND_ERROR 7 INCOMING_PARITY_ERROR 8 OUTGOING_PARITY_ERROR 9 MISSED_INTERRUPT A HUNG_COMMUNICATIONS B LOST_XISR_ERROR C INVALID_BUS_TIMEOUT D VERY_LATE_ECOMM_ISR	Press Go to clear the error message.
56.x PRINTER ERROR alternates with CYCLE POWER TO CONTINUE	Error	A temporary printing error occurred. X Description 1 Illegal input. 2 Illegal output.	1. Press Go . The page containing the error will automatically be reprinted. 2. Turn the printer off, and then turn the printer on. 3. Check the printer's configuration.
57.X FAN FAILURE	Critical Error	A fan motor failure occurred. All fans are enabled to low speed operation at power on. Fans will go into high speed operation during the print cycle. X Description 2 Fan 3 - Formatter Fan (intake) 3 Fan 2 - Low-voltage power supply (exhaust) 5 Fan 1 -Laser/scanner (exhaust)Low-voltage power supply (exhaust) 6 Fan 4 - Face-down delivery (exhaust) 9 Fan 5 - Tray 1 fan	Turn the printer off, and then turn the printer on. If the message continues, check and reseal the cabling between the fan motors and the DC Controller PCA.
58.x PRINTER ERROR alternates with CYCLE POWER TO CONTINUE	Error	A temporary printing error occurred. X Description 1 Tray 1 lifter malfunction. 2 Tray 2 lifter malfunction. 3 Tray 3 lifter malfunction. 4 Tray 4 lifter malfunction. X Tray X lifter malfunction.	Turn the printer off, and then turn the printer on.

Table 7-4. Engine Error Messages (continued)

Control Panel Message	Event Log Error Message	Description	Recommended Action
59.× PRINTER ERROR	Critical Error	A printer error has occurred. X Description 0 Motor error. 1 Motor startup error. 2 Motor rotation error.	Turn the printer off, and then turn the printer on.
62.× PRINTER ERROR	Critical Error	There is a problem with the printer's memory. The × value refers to the location of the problem: 0 = Internal memory 1 to 3 = DIMM slots 1, 2, or 3	Reseat or replace the specified DIMM.
64 PRINTER ERROR	Critical Error	A scan buffer error occurred.	Turn the printer off, and then turn the printer on. If this message persists, replace the Formatter.
68 NVRAM ERROR CHECK SETTINGS	Error	An error occurred in the printer's nonvolatile memory (NVRAM) and one or more printer settings has been reset to its factory default.	<ol style="list-style-type: none"> 1. Print a configuration page and check the printer settings to determine which values have changed. 2. Remove EIO card. It will be reset if not removed. 3. Hold down CANCEL JOB while turning the printer on. This will clean up the NVRAM by removing old areas that are not being used.
68 NVRAM FULL CHECK SETTINGS	Error	The printer's nonvolatile memory (NVRAM) is full. Some settings might have been reset to the factory defaults.	<ol style="list-style-type: none"> 1. Print a configuration page and check the printer settings to determine which values have changed. 2. Remove EIO card. It will be reset if not removed. 3. Hold down CANCEL JOB while turning the printer on. This will clean up the NVRAM by removing old areas that are not being used.
69.× PRINTER ERROR	Critical Error	A temporary printing error occurred. X Description 0 The duplex mechanism has failed. 1 The duplex slide adjust has failed.	<ol style="list-style-type: none"> 1. Turn the printer off, and then turn the printer on. 2. Reseat the duplexer.

Table 7-4. Engine Error Messages (continued)

Control Panel Message	Event Log Error Message	Description	Recommended Action
79.xxxx PRINTER ERROR	Critical Error	The printer detected an error. The numbers (xxxx) indicate the specific type of error.	<ol style="list-style-type: none"> 1. Turn the printer off, and then turn the printer on. 2. Try printing a job from a different software application. If the job prints, go back to the first application and try printing a different file. (If the message only appears with a certain software application or print job, contact the software vendor for assistance.) <p>If the message persists, try the following:</p> <ol style="list-style-type: none"> 1. Cycle power. 2. Reseat or replace the interface cable and cycle power. 3. Remove the DIMMs one at a time and cycle power. 4. Try using the parallel interface, if possible. 5. With the EIO cards removed from the printer, perform a cold reset. 6. Remove the Hard Disk and cycle power. 7. If the error persists, replace the Formatter.
8X.YYYY EIO ERROR	Critical Error	The EIO accessory card in slot X has encountered a critical error as specified by YYYY.	<ol style="list-style-type: none"> 1. Move the EIO card to another slot. 2. If the error persists, replace the EIO card. 3. If the error is corrected, reseat the EIO card in the original slot.
BAD OPT TRAY CONNECTION	Error	The optional tray is not connected properly.	<ol style="list-style-type: none"> 1. Re-install the optional tray. 2. Make sure the optional tray is connected and the connector is not damaged. 3. Replace the optional tray.
CHECK INPUT DEVICE alternates with PAPER PATH OPEN PLEASE CLOSE IT	Error	The optional input tray cannot feed paper to the printer because a door or paper guide is open.	Check the doors and paper guides.

Table 7-4. Engine Error Messages (continued)

Control Panel Message	Event Log Error Message	Description	Recommended Action
CHECK OUTPUT DEVICE alternates with CLOSE OUTPUT DELIVERY PATH	Error	The paper path between the printer and the external paper handling output device is open and must be closed before printing can continue.	Close the paper path.
EXTERNAL DEVICE INITIALIZING	Status	When an external paper handling device is connected to the printer, it must have 10 seconds to initialize after boot or after coming out of PowerSave mode.	No action required.
MANUALLY FEED [SIZE]	Error	Tray 1 does not contain the specified size paper.	Load the specified type of paper into Tray 1.
MANUALLY FEED [TYPE] [SIZE]	Error	One of the following occurred: <ul style="list-style-type: none"> • A manual feed was requested. • There is no paper in Tray 1. • The wrong size paper is loaded. • The control panel is not set for the kind of paper loaded. 	<ol style="list-style-type: none"> 1. Load the requested paper into Tray 1. 2. Press Go if the desired paper is already loaded in Tray 1. 3. Press - VALUE + to scroll through the available types and sizes. 4. Press SELECT to accept the alternate type or size.
MANUALLY FEED [TYPE] ENV	Error	Tray 1 does not contain the specified type of envelope.	Load the specified type of envelope into Tray 1.
MANUALLY FEED TRAY 1 ENVELOPE	Error	Tray 1 does not contain an envelope.	Load an envelope into Tray 1.
OUTPUT BIN FULL alternates with CLEAR PAPER FROM [BINNAME]	Error	The output bin is full and needs to be emptied.	<ol style="list-style-type: none"> 1. Remove the media from the Face-down bin. 2. Make sure that the sensor flag moves freely.
TRAY X CONTAINS UNKNOWN MEDIA	Warning	The media type in the specified tray cannot be determined.	Load known media, or set the correct media type.

Table 7-4. Engine Error Messages (continued)

Control Panel Message	Event Log Error Message	Description	Recommended Action
TRAY X EMPTY	Warning	The paper tray is empty. Paper is sensed in the tray by black plastic flags and photosensors. If paper is not in a tray, the flags will rotate through an access in the upper tray. When paper is present, the flags are blocked from rotating through this access.	<p>1. Load the empty tray (x) to clear the message.</p> <p>If you do not load the specified tray, the printer will continue printing from the next available tray, and the message will continue to display.</p> <p>2. Make sure that the paper out flag is not stuck in the down position by rough media. Do this before opening the tray. To check this flag without opening Tray 2, remove the Duplexer if it is present.</p> <p>3. Open the Front Access Door. This provides you with a clear view of the Tray 2 paper out sensor flag. To check this flag without opening Tray 3, use a flashlight to observe the paper out flag.</p> <p>If either paper flag is damaged, replace the paper flag or the paper input tray.</p> <p>If the printer is using Tray 2 or 3 and the message is accompanied by a clicking noise every few seconds, replace the Paper Input Unit Assembly. See "Paper Input Unit (PIU)" on page 260 for instructions.</p>
TRAY X LIFTING	Error	Displays when tray X is in the process of lifting the paper to the top of the tray for proper feeding.	<p>1. If the message does not go away, verify that the media can be pulled from another tray.</p> <p>2. The Paper Input Unit may need to be replaced. See "Paper Input Unit (PIU)" on page 260 for instructions.</p>
TRAY XX LOAD [SIZE]	Error	Tray X does not contain the specified size of paper.	Load the specified size of paper into Tray X.
TRAY XX LOAD [SIZE]	Error	Tray X does not contain the specified size of paper.	Load the requested paper into the indicated tray, or press SELECT to override the message and to print on a loaded paper size.

Table 7-4. Engine Error Messages (continued)

Control Panel Message	Event Log Error Message	Description	Recommended Action
TRAY ×× LOAD [TYPE] [SIZE]	Error	<p>One of the following occurred:</p> <ul style="list-style-type: none"> • There is no paper loaded in the specified tray, or the paper is not the size requested, or the control panel is not set for the size of paper loaded. • The tray is not properly adjusted for size. • The default paper size is set incorrectly. • If this message appears and the tray contains the correct size of paper, a sensor could be damaged or a paper sensor lever could be stuck. 	<ol style="list-style-type: none"> 1. Load the requested paper into the specified tray (××). Make sure that the trays are correctly adjusted for size. The tray type settings (and size for Tray 1) must be set from the printer's control panel. If you are trying to print A4 or letter size paper and this message appears, make sure that the default paper size is set correctly from the Printing Menu in the printer's control panel. 2. Press Go to print from the next available tray. 3. Press - VALUE + to scroll through the available types and sizes. 4. Press SELECT to accept the alternate type or size. 5. Inspect the switches in the tray. 6. Turn the printer on with the tray removed and push the switches by hand to see if they register.
TRAY X OPEN	Warning	The specified tray is open.	Close the tray to continue.
UNSUPPORTED SIZE IN TRAY [YY]	Error	An external paper handling device detected an unsupported paper size. The printer will go offline until the condition is corrected.	Load a supported paper size in the tray.
USE [TYPE] [SIZE] INSTEAD?	Error	If the requested paper size or type is not available, the printer asks if it should use another paper size or type instead.	<ol style="list-style-type: none"> 1. Press - VALUE + to scroll through the available types and sizes. 2. Press SELECT to accept the alternate type or size.

Input Device Messages

2000-sheet Input Tray Error Messages

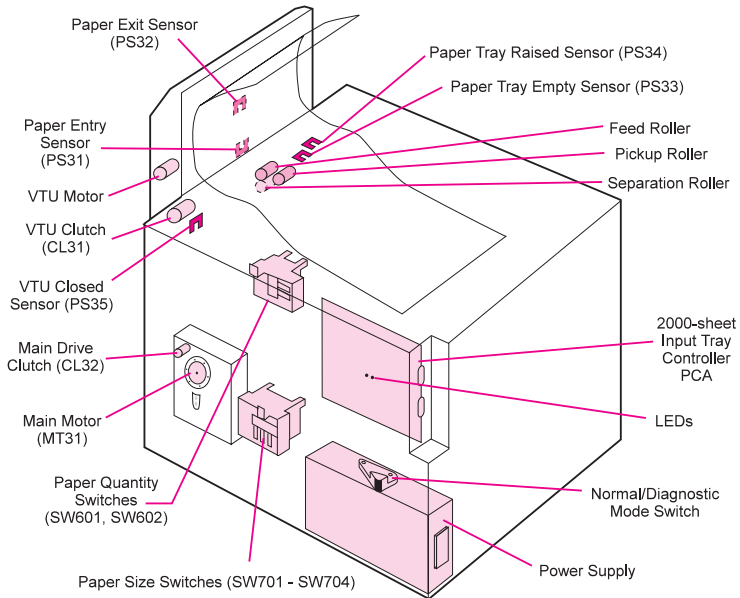

Table 7-5. 2000-sheet Input Tray Error Messages

Control Panel Message	Event Log Error Message	Description	Recommended Action
Input Device Condition 11.01	65.11.01	The detected tray is not consistent with the paper size specified by the Paper Handling Controller.	<ol style="list-style-type: none"> 1. Make sure the size, source, and type of paper selected from the software configuration is correct. 2. Pull out Tray 4 to verify that the size and type of paper loaded matches to the size and type specified in the software configuration.

Table 7-5. 2000-sheet Input Tray Error Messages (continued)

Control Panel Message	Event Log Error Message	Description	Recommended Action
13.11 PAPER JAM IN INPUT DEVICE	13.11 11	Timeout at Entry sensor (PS31) on the 2000-sheet Input Tray	<ol style="list-style-type: none"> 1. Open the Vertical Transfer Unit (VTU) and remove media. 2. Make sure that the ENTRY Sensor (PS31) can move freely. 3. Make sure that the three feed, separation, and pickup rollers are properly seated. 4. If the problem persists, open the VTU and override its Open/Close Door Sensor (PS35), perform a Paper Path Test feeding from the 2000-sheet Input Tray, and make sure the feed rollers are advancing the paper. If rollers do not rotate, verify the connections at the Pickup Assembly and the Controller PCA in the input device. 5. If the rollers rotate and drop down, but do not advance the paper, replace the feed and separation rollers using the maintenance kit. 6. If the rollers do not rotate or do not drop down, replace the Pickup Assembly. 7. If the problem persists, replace the Vertical Transfer Unit (VTU) where sensor (PS31) is located.
	13.11 1B	Timeout at Exit sensor (PS32) on the 2000-sheet Input Tray.	
	13.11 21	Page stays longer at Entry sensor (PS31) on the 2000-sheet Input Tray.	
	13.11 2B	Page stays longer at Exit sensor (PS32) on the 2000-sheet Input Tray.	
13.11 PAPER JAM IN INPUT DEVICE	13.11 31	At power on, Entry sensor (PS31) at the VTU is active.	<ol style="list-style-type: none"> 1. Open the Vertical Transfer Unit (VTU) and remove media. 2. Verify that sensor (PS31 and PS32) moves freely. 3. If any of the sensors (PS31 or PS32) are damaged, replace the Vertical Transfer Unit (VTU).
13.11 PAPER JAM IN INPUT DEVICE	13.11 3B	At power on, Exit sensor (PS32) at the VTU is active.	<ol style="list-style-type: none"> 1. Open the Vertical Transfer Unit (VTU) and remove media. 2. Verify that sensor (PS31 and PS32) moves freely. 3. If any of the sensors (PS31 or PS32) are damaged, replace the Vertical Transfer Unit (VTU).

Table 7-5. 2000-sheet Input Tray Error Messages (continued)

Control Panel Message	Event Log Error Message	Description	Recommended Action
66.11.01 INPUT DEVICE FAILURE	66.11.01	Lifting motor malfunction.	<ol style="list-style-type: none">1. Make sure there are no objects or fragments of paper in the free area at the 2000-sheet Input Tray (Tray 4).2. Make sure that the lifting plate lifts up freely by hand.3. Make sure that the paper size plates are installed correctly, and that they are not bent.4. Replace the Paper Deck Drive Assembly's Bushing, if broken.5. Replace the Paper Deck Drive Assembly.6. Replace the 2000-sheet Input Tray's (Tray 4) paper tray.
66.11.02 INPUT DEVICE FAILURE	66.11.02	Feed motor malfunction.	<ol style="list-style-type: none">1. Make sure there are no objects or fragments of paper in the free area at the 2000-sheet Input Tray (Tray 4).2. Check Paper Tray Raised Sensor (PS34) that is working properly (perform a sensor test).3. Check for proper installation of the Pick up roller.4. Check the Pickup assembly and Paper Deck Drive Assembly cabling.5. Replace the Pickup assembly or the Paper Deck Drive Assembly, if necessary.

Table 7-5. 2000-sheet Input Tray Error Messages (continued)

Control Panel Message	Event Log Error Message	Description	Recommended Action
66.11.03 INPUT DEVICE FAILURE	66.11.03	Lifting and feed motor malfunction.	<ol style="list-style-type: none"> 1. Make sure there are no objects or fragments of paper in the free area at the 2000-sheet Input Tray (Tray 4). 2. Make sure that the lifting plate lifts up freely by hand. 3. Make sure that the paper size plates are installed correctly, and they are not bent. 4. Check for broken Paper Deck Drive Assembly's Bushing, if so replace it. 5. Replace the Paper Deck Drive Assembly. 6. Check Paper Tray Raised Sensor (PS34) is working properly (perform a sensor test). 7. Check for proper installation of the Pickup roller. 8. Check Pickup Assembly cabling. 9. Replace the Pickup Assembly.

2 x 500-sheet Input Tray Error Messages

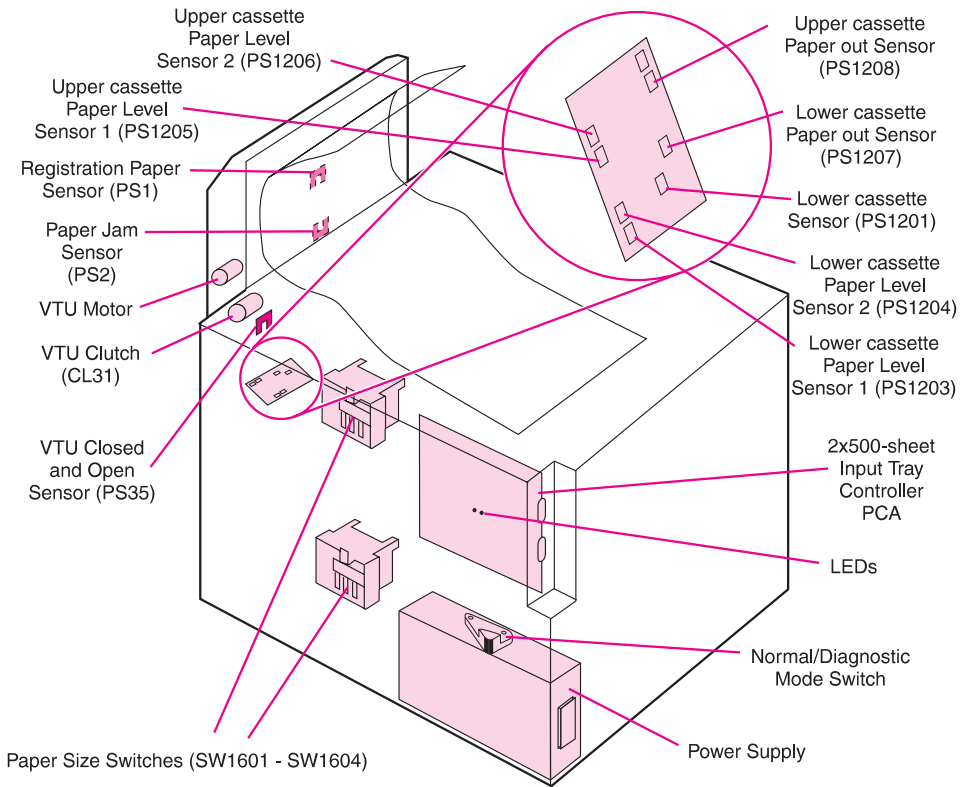

Table 7-6. 2 x 500-sheet Input Tray Error Messages

Control Panel Message	Event Log Error Message	Description	Recommended Action
Input Device Condition 11.01	65.11.01	The detected tray is not consistent with the paper size specified by Paper Handling Controller.	<ol style="list-style-type: none"> 1. Make sure the size, source, and type of paper selected from the software configuration is correct. 2. Pull out tray 4 or 5 to verify that the size and type of paper loaded matches to the size and type specified in the software configuration.

Table 7-6. 2 x 500-sheet Input Tray Error Messages (continued)

Control Panel Message	Event Log Error Message	Description	Recommended Action
Input Device Condition 11.04	65.11.04	Lifter malfunction.	<ol style="list-style-type: none">1. Make sure that the lifting plate lifts up freely by hand.2. Make sure that the paper size plate is installed correctly, and is not bent or broken.3. Replace the Paper Deck Drive Assembly's Bushing, if broken.4. Replace the Paper Deck Drive Assembly.5. Replace the 2 x 500-sheet Input Tray's corresponding paper tray.
Input Device Condition 11.06	65.11.06	Requested to feed more than 4 pages at a time.	<ol style="list-style-type: none">1. Check for proper installation of the Pickup roller.2. Check the Pickup assembly and the Paper Deck Drive Assembly cabling.3. Replace the Pickup assembly or the Paper Deck Drive Assembly, if necessary.

Table 7-6. 2 x 500-sheet Input Tray Error Messages (continued)

Control Panel Message	Event Log Error Message	Description	Recommended Action
13.11 PAPER JAM IN INPUT DEVICE	13.11 11	Page did not arrive at entry sensor.	<ol style="list-style-type: none"> 1. Open the Vertical Transfer Unit (VTU) and remove media. 2. Make sure that the ENTRY Sensor (PS1) can move freely. 3. Make sure that the three feed, separation, and pickup rollers are properly seated. 4. If the problem persists, open the VTU and override its Open/Close Door Sensor (PS35), perform a Paper Path Test feeding from the 2 x 500-sheet Input Tray, and make sure the feed rollers are advancing the paper. If rollers do not rotate, verify the connections at the Pickup Assembly and the Controller PCA in the input device. 5. If the rollers rotate and drop down, but do not advance the paper, replace the feed and separation rollers using the maintenance kit. 6. If the rollers do not rotate or do not drop down, replace the Pickup Assembly. 7. If the problem persists, Replace the Vertical Transfer Unit (VTU) where sensor (PS31) is located.
	13.11 1B	Page did not arrive to exit sensor.	
	13.11 21	Page stays longer at entry sensor.	
	13.11 2B	Page stays longer at exit sensor.	
13.11 PAPER JAM IN INPUT DEVICE	13.11 31	At power on, entry sensor is active.	<ol style="list-style-type: none"> 1. Open the Vertical Transfer Unit (VTU) and remove media. 2. Verify that sensor (PS1 and PS2) moves freely. 3. If any of the sensors (PS1 or PS2) are damaged, replace the Vertical Transfer Unit (VTU).
13.11 PAPER JAM IN INPUT DEVICE	13.11 3B	At power on, exit sensor is active.	<ol style="list-style-type: none"> 1. Open the Vertical Transfer Unit (VTU) and remove media. 2. Verify that sensor (PS1 and PS2) moves freely. 3. If any of the sensors (PS1 or PS2) are damaged, replace the Vertical Transfer Unit (VTU).

Envelope Feeder Error Messages

Table 7-7. Envelope Feeder Error Messages

Control Panel Message	Event Log Error Message	Description	Recommended Action
ENVELOPE FEEDER EMPTY	Warning	The envelope feeder is empty. Printing of the current job is not interrupted.	Refill the envelope feeder.
ENV FEEDER LOAD [SIZE]	Error	The envelope feeder does not have the requested paper.	Put the requested paper into the envelope feeder.
ENV FEEDER LOAD [TYPE] [SIZE]	Error	There is no envelope in the feeder, the wrong size is loaded in the feeder, or the type and size is set incorrectly in the control panel.	<ol style="list-style-type: none"> 1. Load the requested envelope type and size into the envelope feeder. 2. Make sure that the envelope size and type are set correctly from the Paper Handling Menu in the printer's control panel. 3. Press Go if the desired envelope is already loaded in the feeder. 4. Press - VALUE + to scroll through the available types and sizes. 5. Press SELECT to accept the alternate type or size.
WRONG ENVELOPE FEEDER INSTALLED	Error	The envelope feeder you are trying to install will not work for this printer.	Install the correct envelope feeder.

Output Device Messages

7-bin Tabletop Mailbox Error Messages

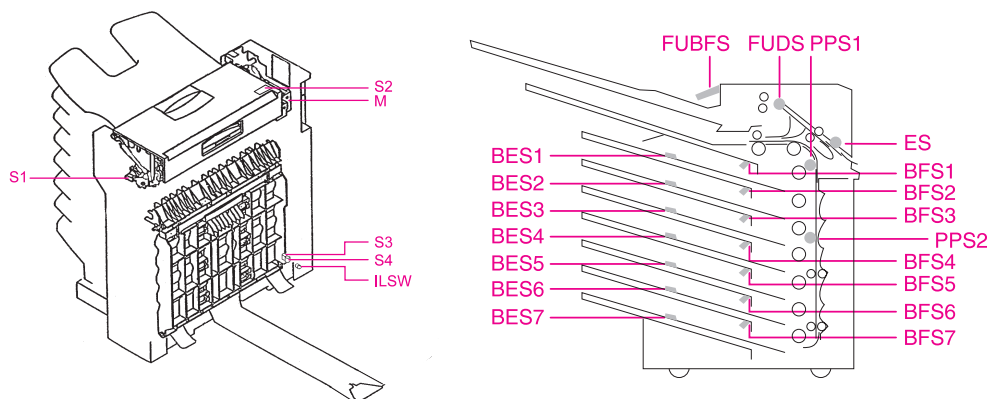

Table 7-8. 7-bin Tabletop Mailbox Error Messages

Control Panel Message	Event Log Error Message	Description	Recommended Action
13.12 or 13.22 PAPER JAM IN OUTPUT DEVICE	13.12 01 or 13.22 01	Unexpected page at (ES) Entry Sensor.	<ol style="list-style-type: none"> 1. Open the Top Cover and remove any jammed paper. 2. Make sure that the Entry Sensor (ES) moves freely. 3. Perform a sensor test to make sure that the Entry Sensor (ES) is working properly. 4. If a problem persists, replace the 7-bin Tabletop Mailbox controller PCA. 5. Replace the sensors PCA.
	13.12.11 or 13.22.11	Page did not reach the Entry Sensor (ES) on time.	<ol style="list-style-type: none"> 1. Open the Top Cover and remove any jammed paper. 2. Make sure that the Entry Sensor (ES) moves freely. 3. Perform a sensor test to make sure that the Entry Sensor (ES) is working properly. 4. If the problem persists, replace the 7-bin Tabletop Mailbox controller PCA. 5. Replace the sensors PCA.

Table 7-8. 7-bin Tabletop Mailbox Error Messages (continued)

Control Panel Message	Event Log Error Message	Description	Recommended Action
13.12 or 13.22 PAPER JAM IN OUTPUT DEVICE (continued)	13.12 12 or 13.22 12	Page did not reach the Paper Path Sensor 1 (PPS1) on time.	<ol style="list-style-type: none"> 1. Open the Paper Path Cover and remove any jammed paper. 2. Make sure that the Paper Path Sensor 1 (PPS1) moves freely. 3. Perform a sensor test to make sure that the Paper Path Sensor 1(PPS1) is working properly. 4. Replace the sensors PCA. 5. If the problem persists, replace the 7-bin Tabletop Mailbox controller PCA.
	13.12 15 or 13.22 15	Page did not reach the Paper Path Sensor 2 (PPS2) on time.	<ol style="list-style-type: none"> 1. Open the Paper Path Cover and remove any jammed paper. 2. Make sure that the Paper Path Sensor 2 (PPS2) moves freely. 3. Perform a sensor test to make sure that the Paper Path Sensor 2 (PPS2) is working properly. 4. Replace the sensors PCA. 5. If the problem persists, replace the 7-bin Tabletop Mailbox controller PCA.
	13.12 17 or 13.22 17	Page did not reach the Face-up Delivery Sensor (FUDS) on time.	<ol style="list-style-type: none"> 1. Open the Top Cover and remove any jammed paper. 2. Make sure that the Face-up Delivery Sensor (FUDS) moves freely. 3. Perform a sensor test to make sure that the Entry Sensor (FUDS) is working properly. 4. If the problem persists, replace the 7-bin Tabletop Mailbox controller PCA. 5. Replace the sensors PCA.
	13.12 21 or 13.22 21	Page stays at Entry Sensor (ES).	<ol style="list-style-type: none"> 1. Open the Top Cover and remove any jammed paper. 2. Make sure that the Entry Sensor (ES) moves freely. 3. Perform a sensor test to make sure that the Entry Sensor (ES) is working properly. 4. If the problem persists, replace the 7-bin Tabletop Mailbox controller PCA. 5. Replace the sensors PCA.

Table 7-8. 7-bin Tabletop Mailbox Error Messages (continued)

Control Panel Message	Event Log Error Message	Description	Recommended Action
13.12 or 13.22 PAPER JAM IN OUTPUT DEVICE (continued)	13.12 22 or 13.22 22	Page stays at Paper Path Sensor 1 (PPS1).	<ol style="list-style-type: none"> 1. Open the Paper Path Cover and remove any jammed paper. 2. Make sure that the Paper Path Sensor 1 (PPS1) moves freely. 3. Perform a sensor test to make sure that the Paper Path Sensor 1(PPS1) is working properly. 4. Replace the sensors PCA 5. If the problem persists, replace the 7-bin Tabletop Mailbox controller PCA.
	13.12 25 or 13.22 25	Page stays at Paper Path Sensor 2 (PPS2).	<ol style="list-style-type: none"> 1. Open the Paper Path Cover and remove any jammed paper. 2. Make sure that the Paper Path Sensor 2 (PPS2) moves freely. 3. Perform a sensor test to make sure that the Paper Path Sensor 2 (PPS2) is working properly. 4. Replace the sensors PCA. 5. If the problem persists, replace the 7-bin Tabletop Mailbox controller PCA.
	13.12 27 or 13.22 27	Page stays at Face-up Delivery Sensor (FUDS).	<ol style="list-style-type: none"> 1. Open the Top Cover and remove any jammed paper. 2. Make sure that the Face-up Delivery Sensor (FUDS) moves freely. 3. Perform a sensor test to make sure that the Entry Sensor (FUDS) is working properly. 4. If the problem persists, replace the 7-bin Tabletop Mailbox controller PCA. 5. Replace the sensors PCA.
	13.12 31 or 13.22 31	Page found at Entry Sensor (ES) during power on sequence.	<ol style="list-style-type: none"> 1. Open the Top Cover and remove any jammed paper. 2. Make sure that the Entry Sensor (ES) moves freely. 3. Perform a sensor test to make sure that the Entry Sensor (ES) is working properly. 4. If the problem persists, replace the 7-bin Tabletop Mailbox controller PCA. 5. Replace the sensors PCA.

Table 7-8. 7-bin Tabletop Mailbox Error Messages (continued)

Control Panel Message	Event Log Error Message	Description	Recommended Action
13.12 or 13.22 PAPER JAM IN OUTPUT DEVICE (continued)	13.12 32 or 13.22 32	Page found at Paper Path Sensor 1 (PPS1) during power on sequence.	<ol style="list-style-type: none"> 1. Open the Paper Path Cover and remove any jammed paper. 2. Make sure that the Paper Path Sensor 1 (PPS1) moves freely. 3. Perform a sensor test to make sure that the Paper Path Sensor 1(PPS1) is working properly. 4. Replace the sensors PCA. 5. If the problem persists, replace the 7-bin Tabletop Mailbox controller PCA.
	13.12 35 or 13.22 35	Page found at Paper Path Sensor 2 (PPS2) during power on sequence.	<ol style="list-style-type: none"> 1. Open the Paper Path Cover and remove any jammed paper. 2. Make sure that the Paper Path Sensor 2 (PPS2) moves freely. 3. Perform a sensor test to make sure that the Paper Path Sensor 2 (PPS2) is working properly. 4. Replace the sensors PCA. 5. If the problem persists, replace the 7-bin Tabletop Mailbox controller PCA.
	13.12 37 or 13.22 37	Page found at Face-up Delivery Sensor (FUDS) during power on sequence.	<ol style="list-style-type: none"> 1. Open the Top Cover and remove any jammed paper. 2. Make sure that the Face-up Delivery Sensor (FUDS) moves freely. 3. Perform a sensor test to make sure that the Entry Sensor (FUDS) is working properly. 4. If the problem persists, replace the 7-bin Tabletop Mailbox controller PCA. 5. Replace the sensors PCA.
66.12.16 or 66.22.16 OUTPUT DEVICE FAILURE	66.12 16 or 66.22.16	Solenoid Malfunction.	<ol style="list-style-type: none"> 1. Check that the 2 parallel black bars that are connected to the Diverter Solenoids (S3 and S4) have free movement. 2. Check for proper installation of the C-link cables. 3. Replace the C-link cables. 4. Replace the 7-bin Tabletop Mailbox controller PCA.

Table 7-8. 7-bin Tabletop Mailbox Error Messages (continued)

Control Panel Message	Event Log Error Message	Description	Recommended Action
66.12.32 or 66.22.32 OUTPUT DEVICE FAILURE	66.12.32 or 66.22.32	Solenoid Malfunction.	<ol style="list-style-type: none">1. Check that the 2 parallel black bars that are connected to the Diverter Solenoids (S3 and S4) have free movement.2. Check for proper installation of the C-link cables.3. Replace the C-link cables.4. Replace the 7-bin Tabletop Mailbox controller PCA.

8-bin Mailbox Error Messages

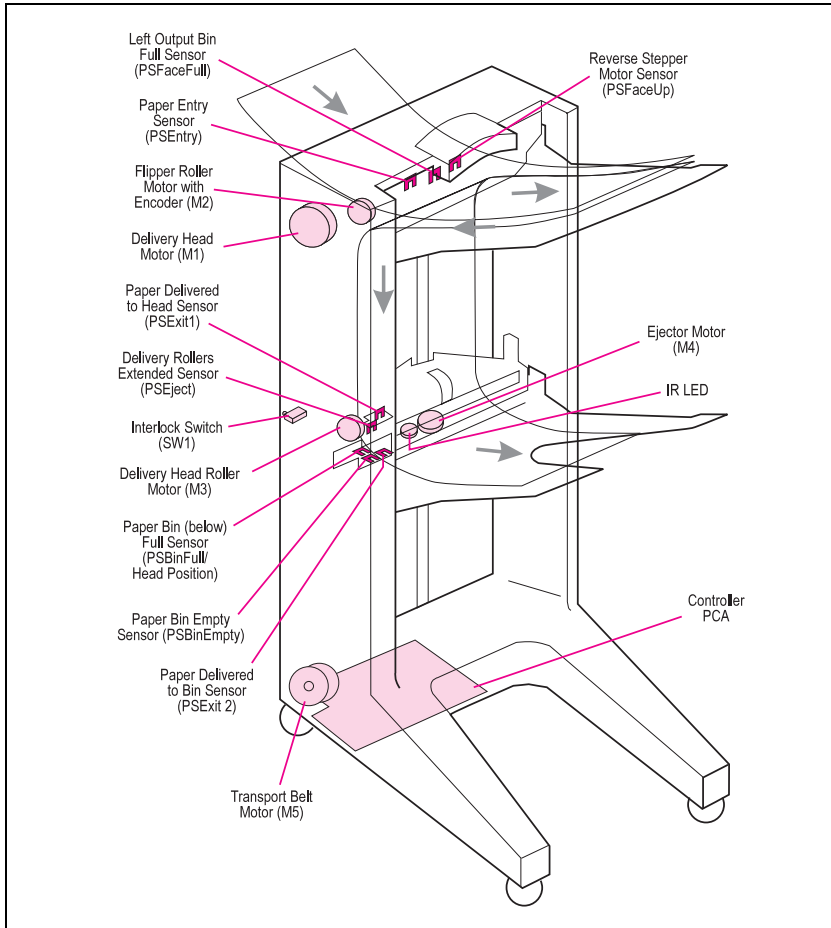

Table 7-9. 8-bin Mailbox Error Messages

Control Panel Message	Event Log Error Message	Description	Recommended Action
22.1 or 12.1 OUTPUT DEVICE CONDITION	65.22.01 or 65.12.01	The Face-up Bin is too full.	<ol style="list-style-type: none"> 1. Empty the Face-up Bin. 2. Check that sensor flag moves freely. (PSFaceFull.) 3. Check for proper cable connection in flipper area. 4. If the problem persists, replace the Flipper assembly.

Table 7-9. 8-bin Mailbox Error Messages (continued)

Control Panel Message	Event Log Error Message	Description	Recommended Action
OUTPUT DEVICE CONDITION 22.2 or 12.2	65.22.02 or 65.12.02	Elevator Problem (Home not Found).	<ol style="list-style-type: none"> 1. Check that the blind cover or scan bar is installed properly. 2. Check for jammed paper in the delivery head assembly. 3. Check for free movement of the delivery head assembly. 4. Check that all paper bins are seated correctly. 5. Check that paper bins or the blind cover are not broken. 6. Replace the delivery head motor. 7. Replace the MBM controller PCA. 8. Replace the delivery head assembly.
OUTPUT DEVICE CONDITION 22.3 or 12.3	65.22.03 or 65.12.03	Elevator Problem Scanning bins Error.	<ol style="list-style-type: none"> 1. Check that the blind cover or scan bar is installed properly. 2. Check for jammed paper in the delivery head assembly. 3. Check for free movement of the delivery head assembly. 4. Check that all paper bins are seated correctly. 5. Check that there is no paper bin or blind cover broken. 6. If the error message persists, replace the delivery head motor (M1), the MBM controller PCA, or the Delivery Head Assembly.
OUTPUT DEVICE CONDITION 22.4 or 12.4	65.22.04 or 65.12.04	Slider Jam in the head assembly.	<ol style="list-style-type: none"> 1. Perform a paper path test. 2. Check for damaged sensor (PSExit 1) or (PSExit 2) in the delivery head assembly. 3. Check fingers in the head assembly, they must be over the ejector rollers. 4. Replace the Head Assembly.

Table 7-9. 8-bin Mailbox Error Messages (continued)

Control Panel Message	Event Log Error Message	Description	Recommended Action
13.22 or 13.12 PAPER JAM IN OUTPUT DEVICE	13.22 01 or 13.12 01	Flipper Entry Sensor (PSEntry) Jam.	<ol style="list-style-type: none"> 1. Open the Jam Access Door and remove any jammed paper. 2. Make sure that the Full Bin Sensor Flag (PSFaceFull) moves freely. 3. Make sure that the Flipper's shaft is not out of place. 4. If the problem persists, replace Flipper Assembly. 5. Replace the MBM Controller PCA.
	13.22 02 or 13.12 02	Flipper Face-up Sensor (PSFaceup) Jam.	<ol style="list-style-type: none"> 1. Open the Jam Access Door and remove any jammed paper. 2. Make sure that the Full Bin Sensor Flag (PSFaceFull) moves freely. 3. Make sure that the Flipper's shaft is not out of place. 4. If the problem persists, replace the Flipper Assembly. 5. Replace the MBM Controller PCA.
	13.22 03 or 13.12 03	Belt Jam (Transport Belt Motor (M5) stop for an unexpected reason).	<ol style="list-style-type: none"> 1. Check for jammed paper at the double-belt system and Delivery Head Assembly. 2. Ensure free movement of the double belt (both belts). 3. Ensure parallel position of the double belt system. 4. Check that the Metal Tape is in place and in good condition. 5. Replace the Transport Belt Motor (M5). 6. Replace the MBM Controller PCA. 7. Replace the Delivery Head Assembly.

Table 7-9. 8-bin Mailbox Error Messages (continued)

Control Panel Message	Event Log Error Message	Description	Recommended Action
13.22 or 13.12 PAPER JAM IN OUTPUT DEVICE	13.22 04 or 13.12 04	Jam in Head Assembly at (PSExit 1).	<ol style="list-style-type: none"> 1. Check for jammed paper in the Delivery Head Assembly. 2. Ensure free movement in (PSExit 1) sensor flags on the delivery head assembly. 3. Check the delivery roller's fingers. They must be over the ejector rollers on the delivery head assembly. 4. Replace the flat ribbon cable that connects to the delivery head assembly to the controller PCA. 5. Replace the MBM Controller PCA. 6. Replace Delivery Head Assembly.
13.22 or 13.12 PAPER JAM IN OUTPUT DEVICE	13.22 05 or 12.12 05	Jam in Head Assembly at (PSExit 2).	<ol style="list-style-type: none"> 1. Check for jammed paper in the Delivery Head Assembly. 2. Ensure free movement in (PSExit 2) sensor flags on the delivery head assembly. 3. Check the delivery roller's fingers. They must be over the ejector rollers on the delivery head assembly. 4. Replace the flat ribbon cable that connects to the delivery head assembly to the controller PCA. 5. Replace the MBM Controller PCA. 6. Replace Delivery Head Assembly.

Table 7-9. 8-bin Mailbox Error Messages (continued)

Control Panel Message	Event Log Error Message	Description	Recommended Action
13.22 or 13.12 PAPER JAM IN OUTPUT DEVICE	13.22 06 or 13.12 06	Elevator (Head Assembly) Jam when scanning and looking for home position.	<ol style="list-style-type: none"> 1. Check for jammed paper in the delivery head assembly. 2. Check that the blind cover is properly installed. 3. Check that the Scan Bar (if stapler unit is installed) is properly seated. 4. Check for free movement of the delivery head assembly. 5. Check that all paper bins are seated correctly. 6. Check for broken paper bins, blind cover, or Scan Bar. 7. Replace the flat ribbon cable that connects to the delivery head assembly to the controller PCA. 8. Replace the delivery head motor (M1). 9. Replace the MBM controller PCA. 10. Replace the delivery head assembly.
13.22 or 13.12 PAPER JAM IN OUTPUT DEVICE	13.22 0A or 13.12 0A	Communication problem. Wrong Page Request.	<ol style="list-style-type: none"> 1. Make sure that all the C-link cables are properly installed and the connectors of this cables are tight enough. 2. Move the 8-bin Mailbox away from the Engine and resend the job. 3. Replace the C-link cables. 4. Perform a Power Cycle. 5. If the error condition persists, replace the Formatter board.
66.12.08 or 66.22.08 OUTPUT DEVICE FAILURE	66.12.08 or 66.22.08	Flipper Motor Malfunction.	<ol style="list-style-type: none"> 1. Check for jammed paper in the Flipper Assembly area. 2. Replace Flipper assembly. 3. Replace the MBM controller PCA.
66.12.09 or 66.22.09 OUTPUT DEVICE FAILURE	66.12.09 or 66.22.09	External Memory Error.	Replace the MBM Controller PCA.

Table 7-9. 8-bin Mailbox Error Messages (continued)

Control Panel Message	Event Log Error Message	Description	Recommended Action
66.12.zz or 66.22.zz OUTPUT DEVICE FAILURE	66.12.zz or 66.12.zz	MBM C-link is not responding.	1. Check for proper installation of the C-link cables. 2. Replace the C-link cables. 3. Replace the 8-bin Mailbox controller PCA.

Finisher Devices Messages

Stapler Error Messages

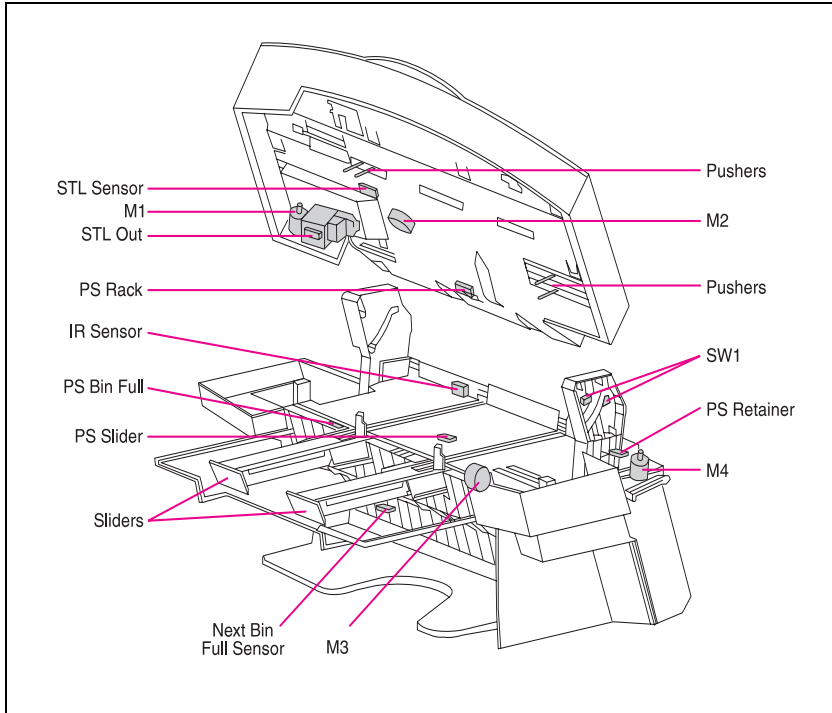

Table 7-10. Stapler Error Messages

Control Panel Message	Event Log Error Message	Description	Recommended Action
CHECK FINISHER DEVICE alternates with CLEAR JAM	Error	A stapler jam or a paper jam occurred.	<ol style="list-style-type: none"> 1. Clear the paper from the stapler. 2. Open the top cover of the stapler and clear the stapler jam. 3. Resend the print job.
CHECK FINISHER DEVICE alternates with FINISHER ALIGN ERROR	Error	The paper is not aligned correctly in the stapler.	<ol style="list-style-type: none"> 1. Remove the paper from the stapler. 2. Resend the print job.

Table 7-10. Stapler Error Messages (continued)

Control Panel Message	Event Log Error Message	Description	Recommended Action
FINISHER LOW ON FINISHING AGENT	Warning	The finishing device is running out of finishing material.	Refill the finishing device.
FINISHER OUT OF BINDING AGENT	Error	The external paper handling finisher device is out of binding agent.	Refill the finishing device.
STAPLER LOW ON STAPLES	Warning	The stapler device is running out of staples.	Refill the stapler device.
STAPLER OUT OF STAPLES	Warning	The external paper handling stapler device is out of staples.	Refill the stapler device.
TOO MANY PAGES IN JOB TO STAPLE	Warning	The external paper handling stapler device received too many pages to staple. The pages will be ejected unstapled.	Staple the pages manually.
13.23 or 13.33 PAPER JAM IN OUTPUT DEVICE	13.33 0A	Staple Jam.	<ul style="list-style-type: none"> • Clear jammed staple. • Replace staple cartridge. • Replace Stapler Top Cover Assembly. • Replace Stapler Controller PCA.
	13.33 0B	Rack Jam.	<ul style="list-style-type: none"> • Remove jammed media. • Perform a device reset cycle by opening and closing the Stapler Top Cover. • Manually move the internal parts of the stapling unit looking for free movement. • Replace the Stapler Top Cover Assembly. • Replace the Stapler Controller PCA
	13.33 0C	Slider Jam.	<ul style="list-style-type: none"> • Remove jammed media. • Perform a device reset cycle by opening and closing the Stapler Top Cover. • Manually move the sliders looking for free movement and observe the power on sequence. • Replace the Stapling Bed Assembly • Replace the Stapler Controller PCA.

Table 7-10. Stapler Error Messages (continued)

Control Panel Message	Event Log Error Message	Description	Recommended Action
13.23 or 13.33 PAPER JAM IN OUTPUT DEVICE	13.33 0D	Retainer Jam.	<ul style="list-style-type: none">• Remove jammed media.• Perform a device reset cycle by opening and closing the Stapler Top Cover.• If the problem persists replace the Stapling Bed Assembly.

Duplexer Error Messages

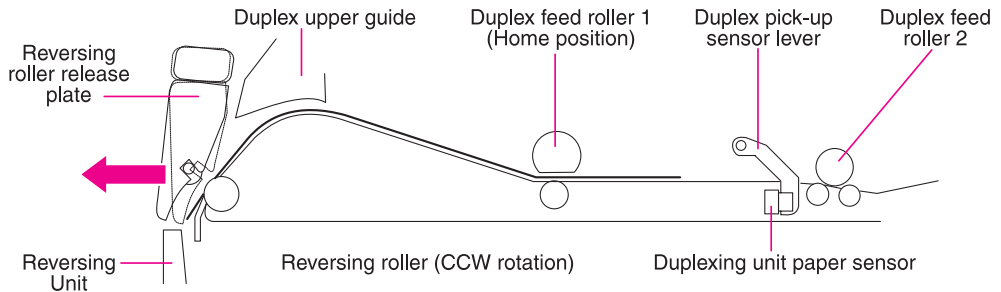

Table 7-11. Duplexer Error Messages

Control Panel Message	Event Log Error Message	Description	Recommended Action
13. 1	13.1 0B	Paper feed 1. Paper late jam. No page from Duplexer.	<ol style="list-style-type: none"> 1. Open the front door, and remove any paper. 2. Open the right door, and remove any paper. 3. Remove any paper from the Duplexer. 4. Perform a Paper Path Test using the Duplexer. 5. Check that the sensors in the Duplexer have free movement. 6. If the problem persists, replace the entire Duplexer Unit.
	13.1 16	Paper feed 1. Paper late jam. Duplexer's 2nd sensor.	
	13.1 1F	Paper feed 1. Paper late jam. Duplexer's 2nd sensor.	
13. 10	13.10 15	Duplex turn around. Paper late jam. Duplexer's 1st sensor.	
13. 11	13.11 04	Duplex turn around. Paper stopped jam. Duplexer's 1st sensor.	
13. 12	13.12 0D	Duplex path. Paper late jam. Duplexer's 2nd sensor.	
13. 20	13.20 08	Could not automatically eject paper.	

Paper Handling Controller Error Messages

Table 7-12. Paper Handling Controller Error Messages

Control Panel Message	Event Log Error Message	Description	Recommended Action
66.00.zz SERVICE ERROR	66.00.01 through 66.00.65	A communication error occurred in the Paper Handling Controller or in the controller PCA of an external paper handling device.	<ol style="list-style-type: none"> 1. Turn the printer off, and then turn the printer on. 2. Replace or exchange C-link cables. 3. If the problem persists, replace the PCA controller board for the input or output device. 4. If the problem persists, replace the Formatter PCA.
66.00.15 SERVICE ERROR	66.00.15	The Paper Handling Controller had a bad C-link (communication) cable. This error could be caused by a power failure.	<ol style="list-style-type: none"> 1. Turn the printer off, and then turn the printer on. 2. If the problem persists, check the C-link and power cables. 3. If the problem persists, check the device power connector and power supply (internal or external). Replace if damaged. 4. If the problem persists, replace the PCA Controller board for the device. 5. If the problem persists, replace the Formatter PCA.
66.00.23 SERVICE ERROR	66.00.23	Error 66.00.23 is due to a bad C-link connection or a damaged C-link cable.	<ol style="list-style-type: none"> 1. Turn the printer off, and then turn the printer on. 2. If the problem persists, replace the PCA Controller board for the input or output device. 3. If the problem persists, replace the Formatter PCA.

Step 4 Paper Path Troubleshooting

Paper jams occur in the printer when paper either does not reach or clear a photosensor along the printer's paper path in a specific amount of time. If a paper jam occurs, a 13.xx PAPER JAM message is displayed on the printer's Control Panel. The following lists general questions you should ask and topics you should explore prior to troubleshooting:

Table 7-13. General Paper Path Troubleshooting Questions

Problem	Action
What is the frequency of the paper jams (e.g. continuous, one jam per 100 pages, one jam per 1000 pages, etc.)?	Verify with the customer. Print or display the Event Log to determine paper jam history. See "Display" on page 538 and "Printer and Paper-Handling Devices Messages" on page 542 and evaluate the Event Log.
Do paper jams only occur when the paper is fed from a particular paper input source (e.g., Tray 1, Tray 2, Tray 3, Tray 4, Tray 5, or Envelope Feeder)?	See "Paper Jams" on page 582 and use the Paper Path Test to isolate the problem.
Do jams only occur when paper is output to a specific output bin (e.g., Face-down bin, Face-up Bin, mailbox bin, duplex operation, stapler)?	Use "Paper Path Test" on page 584 to isolate the problem.
Do paper jams occur with a specific type of media?	Try known good media. See the <i>HP LaserJet Printer Family Paper Specifications Guide</i> .
Where does the leading edge of the first sheet of paper in the printer's paper path stop when a jam occurs? Are any sheets of paper physically damaged or torn?	Attempt to duplicate. See "Paper Path Test" on page 584. Inspect the paper path and all paper path mechanical assemblies prior to the leading paper jam.

Table 7-13. General Paper Path Troubleshooting Questions (continued)

Problem	Action
Is the customer loading the paper trays correctly?	Observe the customer loading the paper. Do not fan the paper. See proper paper handling procedures in the <i>HP LaserJet Printer Family Paper Specifications Guide</i> .
Is the customer overfilling the paper trays?	Make sure that the paper is NOT over the maximum fill marks in the paper trays. Observe the customer loading paper in the trays.
Are the paper tray guides set correctly?	Make sure that the Tray 2 and 3 left-side paper fence is set correctly at both the front and rear of the tray. Make sure that the front fence is locked into the correct position. For Tray 4, make sure that all adjustments are set correctly: front, back, and side at the top and bottom of the tray.
Does the printer need cleaning?	Inspect the paper path and paper path rollers. See “Cleaning the Mopier and Accessories” on page 112.
When was the User Maintenance performed on the printer?	From the Configuration Page, determine the number of pages since the last maintenance (see figure 7-16 on page 590). The Printer Maintenance Kit should be installed every 350,000 images.

Paper Jams

Paper jams occur most often when:

- Paper trays are not correctly loaded. Make sure the paper is loaded with the arrow pointing up in Tray 1 and down in Trays 2, 3, 4, and 5.
- The print media does not meet the specifications listed in the *HP LaserJet Printer Family Paper Specifications Guide*.
- The media is in poor condition.
- The printer needs cleaning.

The printer monitors the timing of four sensors to determine that a paper jam has occurred: PS2, PS1, PS1403, and PS1402.

If a paper jam occurs, the printer will display a 13.x PAPER JAM message on the control panel. See “Printer Message Tables” on page 544 for detailed descriptions of the 13.x messages and the recommended actions to resolve the errors.

Figure 7-13 shows the possible locations for most of the paper jams.

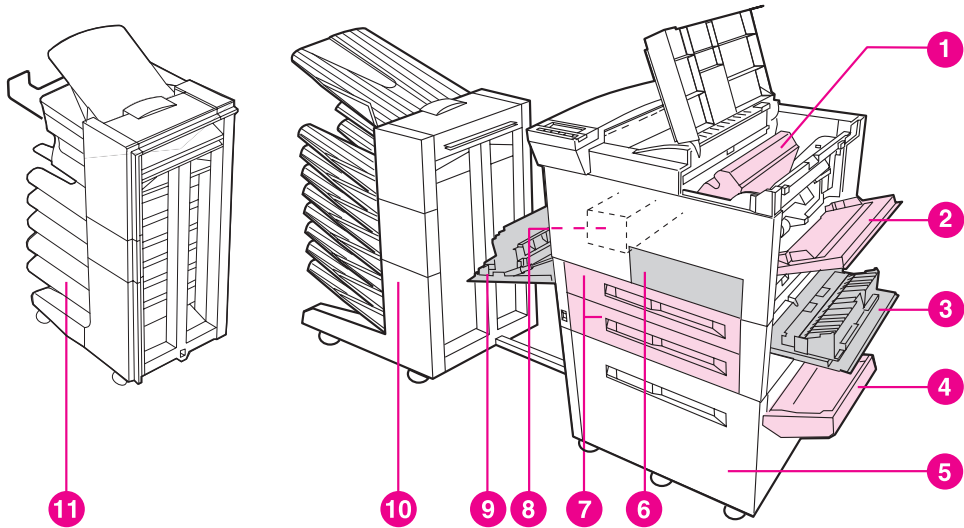

Figure 7-13 Paper Path Jam Locations

- | | | | |
|----------|---|-----------|--|
| 1 | Toner cartridge area | 7 | Tray 2 and Tray 3 |
| 2 | Tray 1 pickup roller and feed area | 8 | Fusing Assembly Area |
| 3 | Right door | 9 | Left door |
| 4 | Tray 4 (2000-sheet Input Tray) and Tray 5 (2 x 500-sheet Input Tray, not shown) transfer door | 10 | 8-bin Mailbox
7-bin Tabletop Mailbox
(not shown) |
| 5 | Tray 4 (2000-sheet Input Tray) and Tray 5 (2 x 500-sheet Input Tray, not shown) | 11 | 5-bin Mailbox with Stapler |
| 6 | Front door | | |

Paper Path Test

Using the error trend information from “Display” on page 538, you can verify a specific printer paper path with the paper path test. You must first set the desired paper destination in the configuration menu and then select the paper path test. The paper path test menu will allow you to select the desired paper source and number.

Note

Feeding paper from Tray 1 will not allow the user to send paper to the Face-down output bins during this test.

Note

If the 8-bin Mailbox is installed, in order to perform the paper path test, the printer must be configured to mailbox mode. If the printer is not in mailbox mode, ask the network administrator to change the configuration to mailbox mode to complete this test.

To perform a paper path test:

- 1 Press **MENU** until `INFORMATION MENU` appears.
- 2 Press **ITEM** until `PRINT PAPER PATH TEST` appears.
- 3 Press **SELECT**.
- 4 Press **+** or **-** until the desired input tray appears.
- 5 Press **SELECT**.
- 6 Press **+** or **-** until the desired output bin appears.
- 7 Press **SELECT**.
- 8 Press **+** or **-** until the desired duplex mode appears.
- 9 Press **SELECT**.
- 10 Press **+** or **-** to choose the desired number of copies.
- 11 Press **SELECT**.

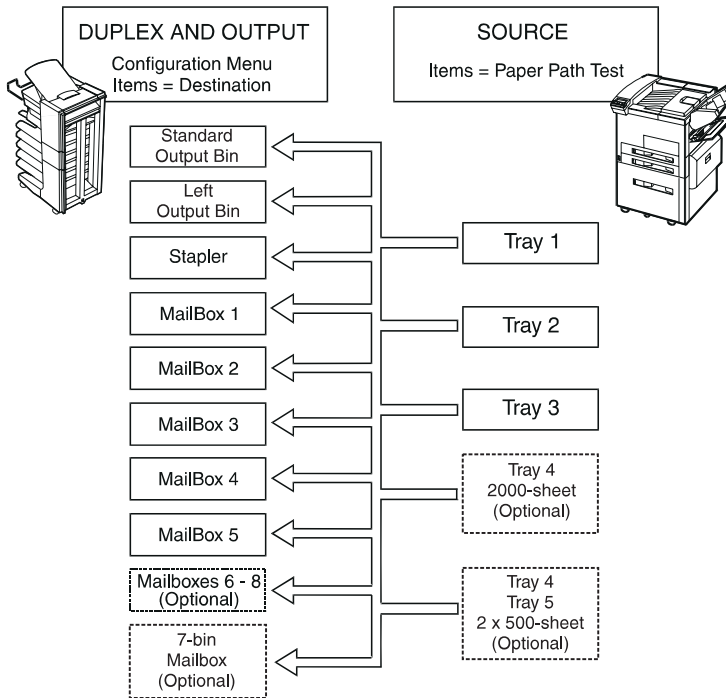

Figure 7-14 Paper Path Test Source and Output Selection

Customer Print Job

Ask the customer to send a print job from the problem source(s) to the problem destination(s). Try to recreate the paper jam errors by having the customer do typical print jobs and the type of print job that has been causing the paper jams.

When verifying print jobs, make sure that all of the settings are selected as desired. Keep in mind that application settings take priority over driver settings, which take priority over the printer control panel settings. If a single setting is not present in the application, but is set in the driver, that will override the front panel settings.

Note

JetAdmin does have capabilities to override paper types and sizes and certain conditions. See the *HP LaserJet 8100, 8100 N and 8100 DN Printers User Guide* for more information.

Clearing Paper Jams

Note

Open and close all printer covers to clear the paper jam message. After removing a sheet of paper, you may need to check other areas to make sure that all paper has been removed.

All portions of a jammed piece of paper must be removed or you may run into repeated jams.

If the jam persists, try the following:

- If you have PostScript installed, use the `JAM RECOVERY=ON` menu item under the PostScript Menu. The printer will attempt to automatically recover from paper jams.
- Execute a formfeed from the computer or the printer's control panel. A formfeed may flush any paper or envelopes left in the printer.
- Check to make sure you have located and removed all scraps of paper from inside the printer.
- Use the Event Log Page and Event Log Codes to aid you in isolating where the errors are occurring.

Clearing Repeated Paper Jams

- 1 Check to see that media is correctly loaded in trays and that all width guides are correctly set (not skewed).
- 2 Try turning over the stack of paper in the tray. If you are using letterhead paper, try printing from Tray 1.
- 3 Do not use previously printed paper or torn, worn, or irregular paper.
- 4 Check the media specifications. If it is outside of the recommended specifications, problems may occur. (See the *HP LaserJet Printer Family Paper Specifications Guide*.)
- 5 The printer may be dirty. Clean the printer as described in the first section of this chapter.
- 6 Check that paper loaded in Tray 1 is NOT longer than 17.7 inches (450 mm) or wider than 11.7 inches (297 mm). (These are the maximum dimensions that the printer can feed; otherwise the printer will jam.)
- 7 Make sure that Tray 4 and Tray 5 are set for the size of paper installed and that the tray is not overloaded with paper.

Step 5 Information Pages

From the printer's Control Panel you can print pages that give details about the printer and its current configuration. The following information pages are described:

- Menu Map (below)
- Event Log (page 538)
- Configuration Pages (page 589)
- File Directory Page (page 592)
- Usage Page (page 593)

For a complete list of the printer's information pages, print a Menu Map and see the Information Menu.

Menu Map

To see the current settings for the menus and items available in the Mopier Control Panel, print a Control Panel Menu Map:

- 1 Press **MENU** until `INFORMATION MENU` appears.
- 2 Press **ITEM** until `PRINT MENU MAP` appears.
- 3 Press **SELECT** to print the Menu Map.

The content of the Menu Map varies, depending on the options currently installed in the printer. The printer driver or software application can override many of these values. See figure 7-15 on page 588 for a sample Menu Map.

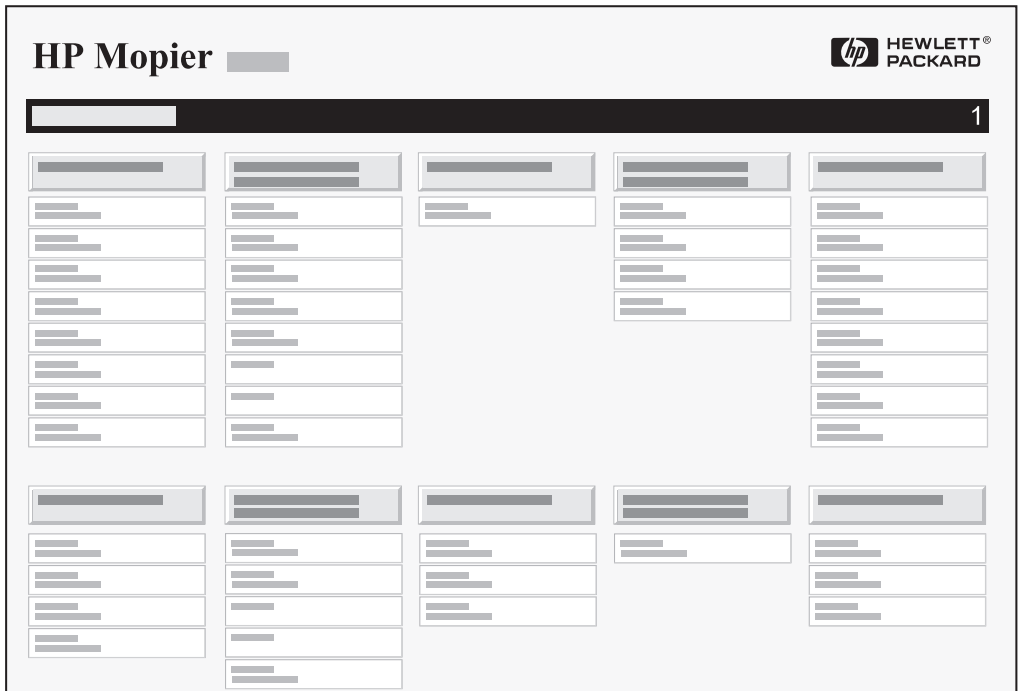

Figure 7-15 Sample Menu Map

Table 7-14. Key to Figure 7-15

Information Menu lets you print information pages and perform a paper path test.

Paper Handling Menu contains paper handling options.

Print Quality Menu lets you set print quality settings.

Printing Menu contains various print options.

Configuration Menu contains various printer settings.

I/O Menu contains communication settings.

Resets Menu shows options for resetting the printer.

Note Items will only appear if options are installed.

Configuration Pages

Use the configuration pages to view current Mopier and copy module settings, help troubleshoot printer problems, or verify installation of optional accessories, such as memory (DIMMs), paper trays, and printer languages.

To print a configuration page from the Mopier control panel:

- 1 Press **MENU** until `INFORMATION MENU` appears.
- 2 Press **ITEM** until `PRINT CONFIGURATION` appears.
- 3 Press **SELECT** to print the configuration page.

See figure 7-16 on page 590 for a sample configuration page. The content of the configuration page varies, depending on the options currently installed in the printer.

If any of the installed devices are not shown on the configuration page, verify that the C-link cabling is correctly connected and functional (figure 7-7 on page 523) and that DC power is available to the paper handling devices. Check and reseal suspect cable connections. If any of the cables are replaced, you must cycle the power to have the printer recognize the device again.

The Menu Map shows current control panel settings. See figure 7-15 on page 588 for a sample Menu Map. See chapter 3 for information about the default settings.

Printer Information

Lists the serial number, HP JetSend IP addresses, page counts, and other information for the printer.

Memory

Lists printer memory, PCL Driver Work Space (DWS), and I/O buffering and resource saving information.

Event Log

Lists the number of entries in the log, the maximum number of entries viewable, and the last three entries.

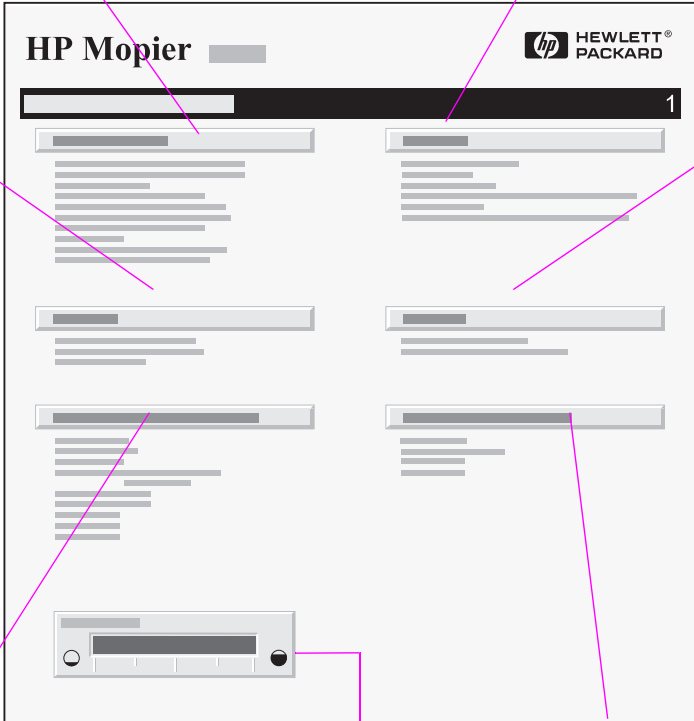

Security

Lists the status of the printer's Control Panel lock, Control Panel password, and disk drive.

Installed Personalities and Options

Lists all printer languages that are installed (such as PCL and PS) and lists the options that are installed in each DIMM slot and EIO slot.

Paper Trays and Options

Lists the size settings for all the trays and lists the optional paper handling devices that are installed.

HP TonerGauge

Indicates the amount of toner remaining in the cartridge. Must be reset at the Control Panel when a new cartridge is installed.

Figure 7-16 Sample Mopier Configuration Page (1 of 2)

General Information

Lists information about the EIO Copy Connect Card, model and serial number, firmware revision, and other information for the copy module.

The image shows a screenshot of the HP Mopier configuration page. At the top, it says "HP Mopier" followed by a greyed-out field. Below that is a black bar with a white "1" on the right. There are several sections of greyed-out text. Three callout boxes with pink lines point to specific areas: "Usage Count Information" points to a greyed-out bar; "Cleaning Counter" points to a bar with a downward arrow; "Maintenance Counter" points to another bar with a downward arrow. Each callout box contains a title and a description of the counter.

Usage Count Information
Indicates total ADF and flatbed scans.

Cleaning Counter
Indicates number of scans since last cleaning. (Reset in service mode).

Maintenance Counter
Indicates number of scans since the last time maintenance was performed. (Reset in service mode).

Figure 7-17 Sample Copy Module Configuration Page

File Directory Page

Print a file directory page to ensure the copy module firmware is loaded on the Mopier's hard disk drive.

To print a file directory page from the Mopier control panel:

- 1 Press **MENU** until `INFORMATION MENU` appears.
- 2 Press **ITEM** until `PRINT FILE DIRECTORY` appears.
- 3 Press **SELECT** to print the file directory page.

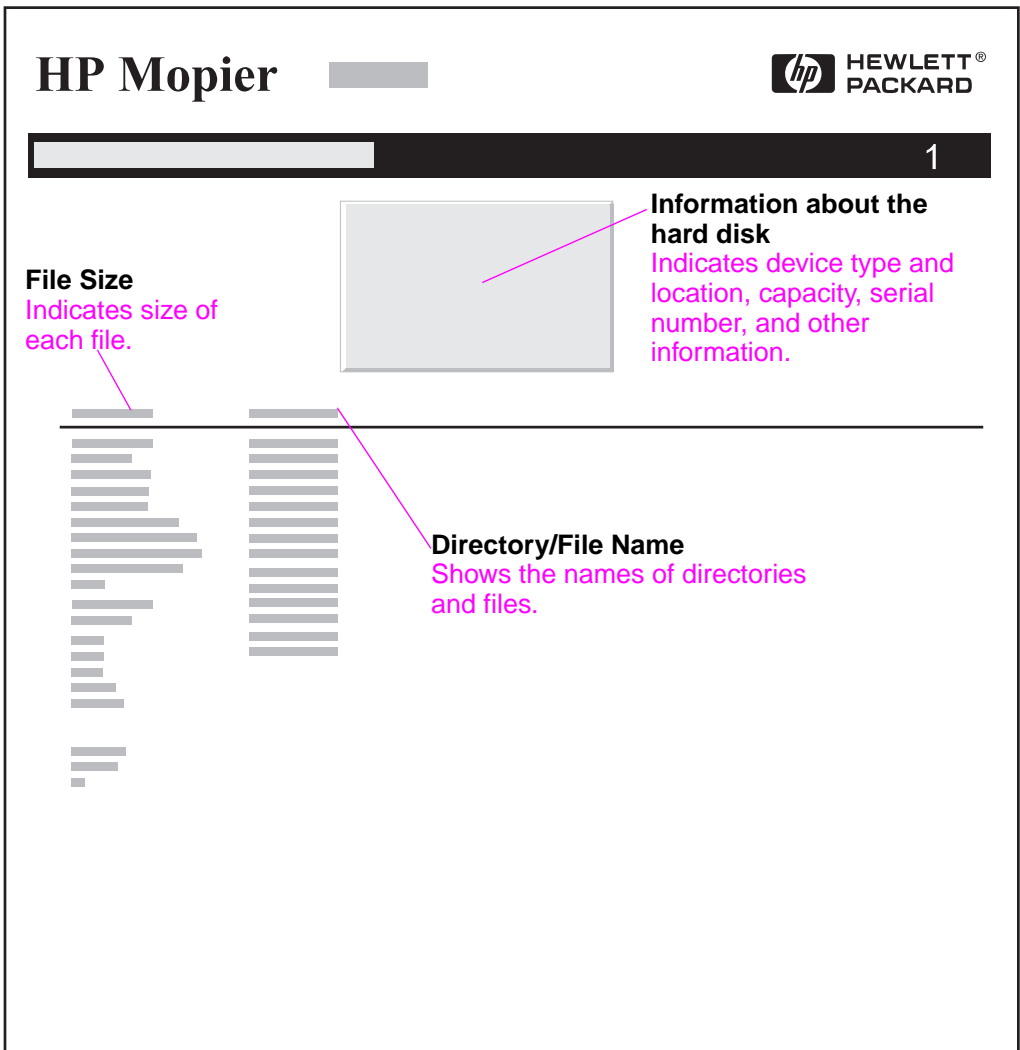

Figure 7-18 Sample File Directory Page

Usage Page

The usage page is designed to fit into a pay-per-page (PPP) model. A reseller can configure the usage page with instructions for a user to send the information back to the reseller in order to prepare bills.

Print a usage page from the Mopier control panel (or access the information remotely from Web JetAdmin) to determine how many simplex or duplex pages of each paper size have been scanned on the copy module and printed on the Mopier. Average toner coverage is approximated by counting pixels. Paper jams are not counted. The data cannot be reset manually and values such as total print and scan impressions, toner coverage, serial number, default language and default paper size are backed up between the Mopier's NVRAM and hard disk.

To print a usage page from the Mopier control panel:

- 1 Press **MENU** until INFORMATION MENU appears.
- 2 Press **ITEM** until PRINT USAGE PAGE appears.
- 3 Press **SELECT** to print the usage page.

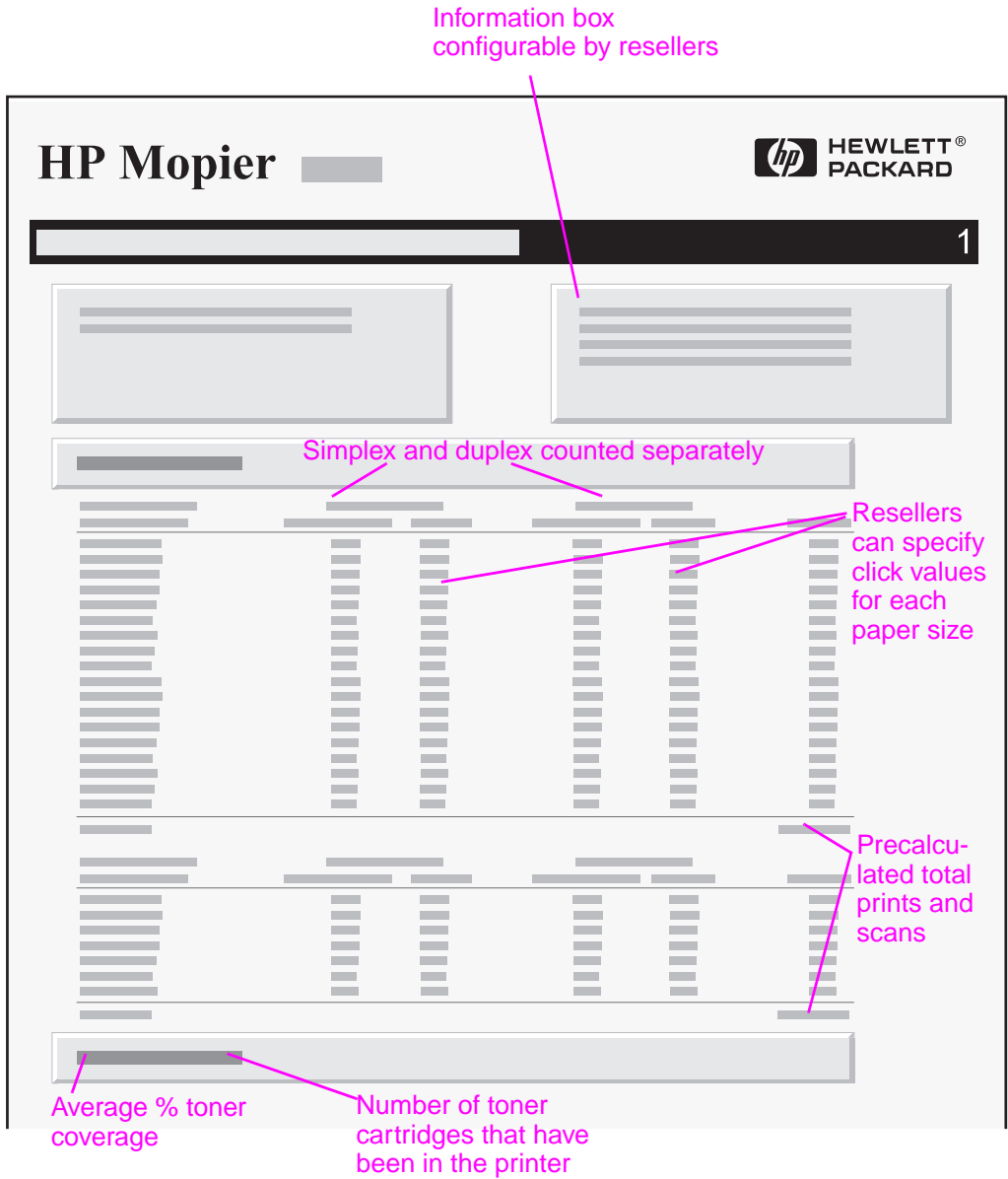

Figure 7-19 Sample Usage Page

Verify Installed Options

In the Installed Personalities and Options section on the configuration page, look for options such as hard disk information and DIMM types RAM or ROM and sizes.

Verify that the options installed in the printer are reflected in the configuration page. If an installed device is not shown on the configuration page, see table 7-15 on page 596 for recommended actions.

The Paper Tray and Options section of the configuration page identifies two types of paper handling devices that communicate or interact with the printer:

- Engine DC controller-driven devices
 - Duplexer
 - Envelope Feeder
- Communication Link Devices (C-link protocol)
 - **Input devices:**
 - 2000-sheet Input Tray
 - 2 x 500-sheet Input Tray
 - **Output devices:**
 - 8-bin Mailbox
 - 5-bin Mailbox with Stapler (includes a finisher)
 - 7-bin Tabletop Mailbox

While the engine DC controller-driven devices draw power (24V DC) and control signals from the engine, the C-link devices have their own power supply and controller board.

The information from the Paper Handling Controller is carried by the C-link cables that connect the controller board of all the C-link protocol supported devices. The C-link protocol supports up to 5 devices connected to the paper handling controller in a daisy chain. Each device controller has an input or output port that provides flexible connections in different configurations. However, it is recommended to use the configuration shown in figure 7-7 on page 523 to avoid rearrangements in the supported device numbering and confusions when evaluating the Event Log.

Table 7-15. Printer Devices Troubleshooting

Device	Action if installed and not detected
Duplexer	Turn the power off, reseal the Duplexer, verify that the connector is not broken, and turn the printer on. If the connector is broken or turning the printer on and off does not work, then replace the duplex cable and/or duplexer.
Envelope Feeder	Turn the power off, reseal the envelope feeder, and turn the printer on. If this does not work, replace the envelope feeder.
Device 1 2000-sheet Input Tray	Verify that the C-link cables are installed correctly (see figure 7-7 on page 523). Remove all C-link connections and visually inspect for connector damage on the cable pins and connector ends.
Device 2 8-bin Mailbox	Try using a different cable to connect the problem device directly to the Paper Handling Controller. All C-link cables are wired the same, but are different lengths.
Device 3 Stapler	If a device is not recognized, replace the device controller or defective C-link cable.
Device 1 2 x 500-sheet and 2000-sheet Input Tray	Verify that AC power is present in the 2000-sheet or 2 x 500-sheet Input Tray. Verify that the C-link cable is connected properly to the Paper Handling Controller or the tray will not lift.
Device 2 7-bin Tabletop Mailbox	Verify that the DC power supply is receiving power. Verify that the DC power supply output is connected to the 8-bin Mailbox controller. Verify that the C-link cables are properly installed and external power applied. Check if Fuse F202 in the 2 x 500-sheet or 2000-sheet Input Tray's Controller PCA is blown. Replace the DC power supply. Replace the 8-bin Mailbox controller.

Step 6 Image Quality

When you are working with customers, obtain a print sample before you begin troubleshooting their printer. Ask the customer to explain the quality they expect from the printer. The print sample will also help clarify the customer's explanation and expectations.

Table 7-16. Image Quality

Problem	Action
1. Do you have a print sample?	Obtain a print sample from the customer.
2. Does the problem repeat on the page?	Use the Repetitive Defect Ruler in figure 7-20 on page 613.
3. Is the toner cartridge full and is it manufactured by HP?	Check the toner cartridge using the check list on page 598.
4. Is the printer clean?	Perform the cleaning procedure described in "Cleaning the Mopier and Accessories" on page 112.
5. Is the customer using print media that meets all HP paper specification standards?	For more information about HP's paper specification standards, see "Paper Capacities and Sizes" on page 11 and the <i>HP LaserJet Family Paper Specification Guide</i> .
6. Is the print sample similar to those in the "Image Quality Tables" on page 599?	Compare and perform the actions recommended in "Image Quality Tables" on page 599.
7. Is the problem on the drum or transfer roller?	Perform the steps in "Half Self Test Functional Check" on page 614 to determine where the defect is. If the defect is on the drum, replace the toner cartridge. If it is not on the drum, replace the transfer roller.

Check the Toner Cartridge

Image formation defects are often the result of toner cartridge problems. If there is any doubt, always replace the toner cartridge before troubleshooting image defects.

Use the following check list to make sure that the toner cartridge is still operable.

- Make sure that the toner cartridge has toner.
Full toner cartridge weight = 3200 grams (114 oz)
Empty weight = 2200 grams (80.5 oz)
- Check the expiration date of the toner cartridge (stamped on the cartridge box).
- Check the toner cartridge to see if it has been disassembled or refilled.
- Make sure that the toner cartridge is seated properly in the printer cavity.
- Inspect the cartridge for toner leaking through worn seals. (If the drum has been manually rotated it may have caused internal damage and toner spills may result.)

Note

Toner cartridges are rated for 20,000 images at 4% coverage. It is possible to wear out the gears and the cartridge seals before **TONER LOW** is displayed if the 20,000 image expectancy is exceeded.

- Check the surface of the photosensitive drum in the toner cartridge to see if it has been damaged or scratched. Touching the drum will contaminate the photosensitive surface and may cause spotting and defects during printing.
- White areas on the page may indicate that the drum has been exposed to light for too long. If white areas appear, stop the printer and wait a few minutes. This should eliminate most defective images. If not, the toner cartridge may be placed in a dark environment for several days, which may restore some life to the drum.

Image Quality Tables



Table 7-17. Blank (White) Page

Possible Cause

Recommended Action

OCCASIONAL BLANK PAGES:

1. **Software Configuration.**

Make sure that the application software is not sending incorrect page length requests, or extra page eject commands.

2. **Network Configuration.** Some sharing devices on networks may generate a blank page as a separator.

Check with the network administrator.

3. **Multiple Feeds.** The printer may be feeding two or more pages at once because the paper is difficult to separate.

Remove the paper from the tray and bend the stack to separate the pages (see the *HP LaserJet Printer Family Paper Specifications Guide*).

ALL PAGES BLANK:

1. **Sealing tape left in toner cartridge.** Remove the sealing tape.



Table 7-18. Black Pages

Possible Cause

Recommended Action

1. **Defective toner cartridge.**

Replace the toner cartridge.

2. **Light is leaking into the printer.**

Make sure that all covers are in place.

Table 7-18. Black Pages (continued)

Possible Cause	Recommended Action
3. High voltage contact springs are dirty or defective. The high voltage contacts are mounted on the High Voltage Power Supply PCA and protrude into the toner cartridge cavity.	Inspect and clean the high voltage contacts. If damaged, replace the High Voltage Power Supply PCA. See “High Voltage Power Supply (HVPS)” on page 269 for instructions.
4. High voltage power supply circuit is defective (not supplying the correct negative voltage).	Replace the High Voltage Power Supply PCA. See “High Voltage Power Supply (HVPS)” on page 269 for instructions.
5. DC Controller PCA is defective. If the DC Controller turns on the laser beam continuously, the entire surface of the Photosensitive drum is neutralized causing a completely black page.	Replace the DC Controller PCA. See “PCA, DC Controller” on page 261 for instructions.
6. Laser/Scanner Assembly is faulty (turning laser on continuously).	Replace the Laser/Scanner Assembly. See “Laser/Scanner Assembly” on page 254 for instructions.
7. Connectors between the Laser/Scanner unit and DC Controller are not seated properly or are defective.	Inspect and reseat the connectors. Replace cables as necessary.

Table 7-19. Fading Print

Possible Cause	Recommended Action
1. Toner supply is low.	Shake the cartridge gently to redistribute the toner, or replace the cartridge.
2. Print Density is set incorrectly.	Change to a darker setting and retry printing.

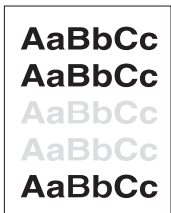



Table 7-19. Fading Print (continued)

Possible Cause	Recommended Action
3. EconoMode is on. EconoMode saves toner by reducing the dot density. This may appear to be a print quality problem in some cases.	Turn EconoMode off. Verify that EconoMode is not being enabled by either the printer driver or the job application.
4. Paper does not meet specifications. The moisture content, conductivity, or surface finish may not work correctly with the electrophotographic process.	Try a different paper lot (see <i>HP LaserJet Printer Family Paper Specifications Guide</i>).
5. Transfer Roller is defective or incorrectly installed. If the Transfer Roller loses conductivity, it cannot effectively pull toner from the drum to the paper.	Inspect the Transfer Roller for proper installation and contact. If the Transfer Roller is damaged, replace it. See "Transfer Roller Assembly" on page 282 for instructions.
6. Laser/Scanner door is not opening properly.	<ol style="list-style-type: none">1. Remove and reseal the toner cartridge.2. Check the Laser/Scanner shutter door for proper operation. If defective, replace the Laser/Scanner Assembly. See "Laser/Scanner Assembly" on page 254 for instructions.
7. High voltage contact springs are dirty or defective. The high voltage contacts are mounted on the High Voltage Power Supply PCA and protrude into the toner cartridge cavity.	Check the contacts for functionality. If dirty, clean using alcohol; if damaged, replace the High Voltage Power Supply PCA. See "High Voltage Power Supply (HVPS)" on page 269 for instructions.
8. High Voltage Power Supply PCA is defective.	Replace the High Voltage Power Supply PCA. See "High Voltage Power Supply (HVPS)" on page 269 for instructions.
9. DC Controller PCA is defective. The DC Controller supplies the proper voltage to the High Voltage Power Supply PCA.	Replace the DC Controller PCA. See "PCA, DC Controller" on page 261 for instructions.



Table 7-20. Dropout

Possible Cause	Recommended Action
1. Single sheet of paper is defective.	Try reprinting the job.
2. Paper does not meet specifications. The moisture content, conductivity, or surface finish may not work correctly with the electrophotographic process.	Try a different paper lot (see <i>HP LaserJet Printer Family Paper Specifications Guide</i>).
3. DC Controller is defective (low primary voltage).	Replace the DC Controller. See "PCA, DC Controller" on page 261 for instructions.
4. High Voltage Power Supply PCA is defective.	Replace the High Voltage Power Supply PCA. See "High Voltage Power Supply (HVPS)" on page 269 for instructions.
5. Transfer Roller is defective.	Replace the Transfer Roller. See "Transfer Roller Assembly" on page 282 for instructions.

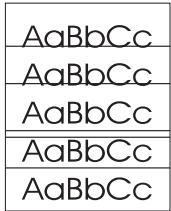

Table 7-21. Black Lines (parallel or perpendicular to path)

Possible Cause	Recommended Action
1. Toner cartridge is not seated properly.	Remove the cartridge and reinsert it.
2. Toner cartridge is damaged.	Inspect the toner cartridge for a scratched or streaked photosensitive drum. Clean the printer (see "Cleaning the Mopier and Accessories" on page 112), and replace the cartridge.

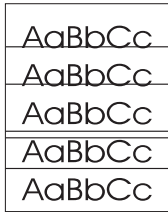

Table 7-21. Black Lines (parallel or perpendicular to path)

Possible Cause	Recommended Action
3. Fusing Assembly is contaminated or damaged.	Inspect the Fusing Assembly for toner build-up or scratches on the fuser rollers. Replace the Fusing Assembly if damaged. See “Fusing Assembly” on page 252 for instructions.
4. Static Eliminator Strip teeth are contaminated or defective.	Clean using compressed air. Be careful not to spray the Transfer Roller.
5. Repetitive defect. If the lines are repeated at a consistent interval down the page, this is a repetitive defect.	See the Repetitive Image Defect Ruler (figure 7-20 on page 613).



Table 7-22. Toner Smear

Possible Cause	Recommended Action
1. Paper does not meet specifications. The moisture content, conductivity, or surface finish of the media being printed may not work correctly with the electrophotographic process.	Try a different paper lot or other media (see <i>HP LaserJet Printer Family Paper Specifications Guide</i>).
2. Fusing Rollers are dirty. Toner build-up can cause the print on a page to smear.	Remove and inspect the Fusing Assembly for excessive toner build-up.
3. The Static Eliminator Strip is dirty or is not grounded, allowing a static charge to remain on the page.	Clean the Anti-Static Brush using compressed air.



Table 7-22. Toner Smear (continued)

Possible Cause	Recommended Action
4. Fusing Assembly is defective. The print will smear if the Fusing Assembly is not heated sufficiently to bond the toner image to the paper.	Replace the Fusing Assembly. See “Fusing Assembly” on page 252 for instructions. Try changing fuser modes depending on the type of media used.
5. DC Controller is defective. The DC Controller regulates fusing roller temperature.	If a new Fusing Assembly does not resolve the problem, replace the DC Controller PCA. See “PCA, DC Controller” on page 261 for instructions.



Table 7-23. Background Scatter

Possible Cause	Recommended Action
Random Background Scatter	
1. Paper does not meet specifications. The moisture content, conductivity or surface finish may not work correctly with the electrophotographic process.	Try a different media or paper lot (see <i>HP LaserJet Printer Family Paper Specifications Guide</i>).
2. Inside of printer is dirty (toner may have leaked out of the toner cartridge).	Clean inside of printer (see “Cleaning the Mopier and Accessories” on page 112). Install a new toner cartridge if leaking.
3. Printing on envelope seams. Printing on an envelope seam can cause a background scatter problem.	Move the text to an area without seams. If not printing on seams, try a higher print density setting (see item 6, below).
4. Toner cartridge is defective.	Install a new toner cartridge.

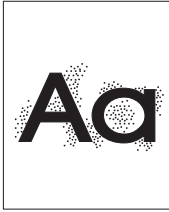

Table 7-23. Background Scatter (continued)

Possible Cause	Recommended Action
5. Transfer Roller is dirty or worn. A worn Transfer Roller can cause background scatter due to improper bias voltages.	Clean the Transfer Roller using a dry, lint-free cloth. DO NOT touch the Transfer Roller with your fingers. If the problem persists, replace the Transfer Roller Assembly. See “Transfer Roller Assembly” on page 282 for instructions.
6. Print Density is set too low, causing background scatter, particularly with envelopes and heavier papers.	Adjust the print density to a higher setting.

Background Scatter at Leading Edge Only (Leading Edge Halo)

1. Toner buildup in the Fuser Inlet Guide.	Clean Fuser Inlet Guide. See “Cleaning the Mopier and Accessories” on page 112 for instructions.
--	--

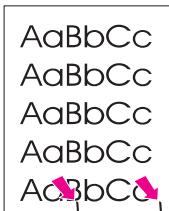

Table 7-24. Repetitive Defects

Possible Cause	Recommended Action
1. Toner cartridge is damaged. If the defect repeats at any of the following intervals and in the direction of paper movement, it is associated with a component inside the toner cartridge. See figure 7-20 on page 613.	Inspect the drum for scratches or damage. Replace the toner cartridge. Use the Repetitive Defect Ruler, figure 7-20 on page 613.
2. Transfer Roller has toner on it. If defects occur on the back of the page at intervals of 54mm (2.3 inches), the Transfer Roller may be dirty. This problem sometimes corrects itself after a few pages.	Clean the Transfer Roller using a dry, lint-free cloth. DO NOT touch the Transfer Roller with your fingers. If the problem persists, replace the Transfer Roller Assembly. See “Transfer Roller Assembly” on page 282 for instructions.

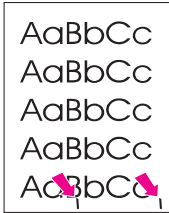

Table 7-24. Repetitive Defects (continued)

Possible Cause	Recommended Action
3. Rollers are dirty. Any dirty roller in the paper path may result in a repetitive print defect.	Examine and clean the rollers in the paper path. See “Cleaning the Mopier and Accessories” on page 112.
4. Fusing Assembly is dirty or defective.	Clean the Fusing Assembly using alcohol. If the problem persists, replace the Fusing Assembly. See “Fusing Assembly” on page 252 for instructions.
5. Gears are worn, causing slippage or jumping.	Inspect the gears driving the toner cartridge and the Fuser. Replace the Main Drive Assembly if necessary. See “Main Gear Assembly” on page 256 for instructions.
6. Paper does not meet specifications. The surface of the paper may be too coarse, causing repeated marks.	Try a different media or paper lot (see <i>HP LaserJet Printer Family Paper Specifications Guide</i>).



Table 7-25. Line at Edge of Paper

Possible Cause	Recommended Action
Toner cartridge is defective. The photosensitive drum is wearing out. The line will grow wider, with cross-hatching. Shaking the cartridge does not relieve the problem.	Replace the toner cartridge.

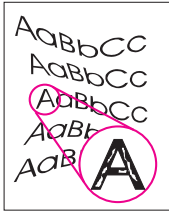

Table 7-26. Misshapen Characters, Voids

Possible Cause

Recommended Action

1. Paper surface too rough. Toner migrates to low spots, leaving higher areas void.

Turn EconoMode off. Use paper with correct finish (smoothness) (see *HP LaserJet Printer Family Paper Specifications Guide*).

2. Printing on wrong side of paper. The label on the ream of paper indicates which side to print on. The different surface properties of some papers may cause problems if loaded wrong side up.

Turn EconoMode off. Check for the arrow on the paper wrapper. Be sure paper is loaded with the arrow pointing up in Tray 1 or down in Trays 2, 3, 4, and 5.

3. Paper surface is too smooth for proper toner adhesion.

Turn EconoMode off. Use paper with correct finish (smoothness) (see *HP LaserJet Printer Family Paper Specifications Guide*).

4. Transparencies are bad. Transparencies can have this problem because they are not designed for proper toner adhesion.

Turn EconoMode off. Use Hewlett-Packard approved transparencies (see *HP LaserJet Printer Family Paper Specifications Guide*).

5. Transfer Roller is bad. If the Transfer Roller has finger oils on its surface, is dirty, or is worn-out, this problem can result.

Turn EconoMode off. Clean the Transfer Roller using a dry, lint-free cloth. DO NOT touch the Transfer Roller with your fingers. If the problem persists, replace the Transfer Roller Assembly. See "Transfer Roller Assembly" on page 282 for instructions.

6. Laser/Scanner Assembly is bad.

Replace the Laser/Scanner Assembly. See "Laser/Scanner Assembly" on page 254 for instructions.



Table 7-27. Faulty Registration

Possible Cause	Recommended Action
1. Paper tray is overloaded. If the tray is overloaded, the Pickup Rollers may not pick correctly.	Reload proper amount of paper squarely in the tray. Review paper loading with the customer.
2. Paper guide on the paper tray is incorrectly adjusted. If the guide is pushing too tightly against the paper, it may be delayed in being pulled into the printer. If the guide is too loose, it may cause image skewing.	Make sure that the paper guide is adjusted for the correct paper size and is locked into position.
3. Paper does not meet specifications. The surface of the paper may be too smooth for the Pickup and Feed Rollers to correctly feed paper into the printer.	Try a different paper lot (see <i>HP LaserJet Printer Family Paper Specifications Guide</i>).
4. Drive gears are worn or broken. If any gear within the drive train or paper path becomes excessively worn or dirty, erratic paper movement can result.	Replace the defective gear or Main Drive assembly. See “Main Gear Assembly” on page 256 for instructions.
5. Worn Pickup or Registration Rollers. Paper is not being picked up consistently.	Inspect all paper path rollers, looking for wear, cracks, or glazing. Replace the worn rollers.

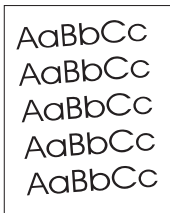

Table 7-28. Image Skew

Possible Cause	Recommended Action
1. Paper is loaded incorrectly. If the paper is not installed flush into the paper tray, a skewing problem will result.	Remove paper from the tray, and install paper correctly. Position the paper guide correctly for the paper size being used.
2. Paper size adjustment levers are missing or installed incorrectly.	Verify and correct.

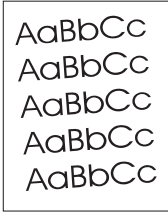

Table 7-28. Image Skew (continued)

Possible Cause	Recommended Action
3. Paper lot is bad. Paper that is manufactured poorly or inconsistently or that has too smooth or too rough a surface texture can cause an image skew problem.	Try a different paper lot (see <i>HP LaserJet Printer Family Paper Specifications Guide</i>).
4. Pickup and/or Registration Rollers are worn. Paper is not being picked up consistently.	Inspect all paper path rollers, looking for wear, cracks, or glazing. Replace the worn rollers.

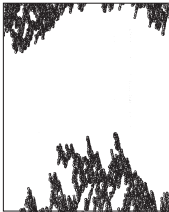

Table 7-29. Bubble Print

Possible Cause	Recommended Action
1. Photosensitive drum inside toner cartridge is not grounded.	<ol style="list-style-type: none">1. Check for proper mounting of the High Voltage Power Supply (HVPS) and the HVPS ground contacts on the toner cartridge.2. Check for proper seating of toner cartridge.3. Replace the toner cartridge.
2. Toner cartridge is leaking.	Replace the toner cartridge.
3. Paper does not meet specifications. The moisture content, conductivity, or surface finish may not work correctly with the electrophotographic process.	Try a different paper lot (see <i>HP LaserJet Printer Family Paper Specifications Guide</i>).
4. High Voltage Power Supply is defective.	Replace the High Voltage Power Supply. See “High Voltage Power Supply (HVPS)” on page 269 for instructions.

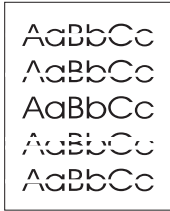

Table 7-30. White Stripes Parallel to Path

Possible Cause

Recommended Action

1. Toner cartridge is nearly empty. This can cause uneven toner distribution.

Remove the toner cartridge, and shake it gently. The cartridge will soon require replacement.

2. Toner cartridge has been exposed to too much light.

Store the toner cartridge in a darkened environment for several days. This may restore the photosensitive potential.

3. Foreign objects in beam path. Any foreign objects will block the light from developing an image on the Photosensitive drum.

Remove the toner cartridge, and check for damage. Replace the toner cartridge if it is damaged.

Remove the printer cover, and inspect the path from the Laser/Scanner to the toner cartridge drum, looking for foreign objects in the beam path.

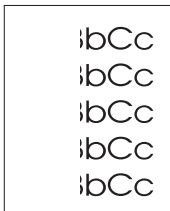

Table 7-31. Partial Blank Page

Possible Cause

Recommended Action

1. Page is too complex. The printer cannot create the image fast enough to keep pace with the print engine.

Set Page Protect to on or auto. Simplify print job.

2. Not enough memory. The page is too complex for standard printer memory.

Add printer memory. See “Memory and Personality Upgrade” on page 204 for instructions. As an alternative, simplify the print job.

3. Printing on legal-size paper from Tray 4 when software is specifying letter size (this will also cause paper jams).

Review software selection. Make sure that printing is on selected size.



Table 7-32. Compressed Print

Possible Cause	Recommended Action
1. Toner cartridge bushings are too tight. This may occur on refilled toner cartridges.	Replace the toner cartridge.
2. Gear is broken or worn.	Inspect and replace the worn gear or assembly.

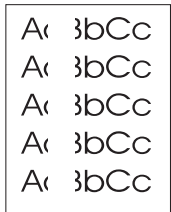

Table 7-33. Blank Portion in the Middle of the Page (Tray 4 Input only)

Possible Cause	Recommended Action
1. Bad clutch in vertical transfer door.	Replace the Tray 4 vertical transfer door.
2. Bad clutch in paper pickup assembly.	Replace Tray 4 paper pickup assembly.

Repetitive Defect Ruler

Repetitive print defects are usually associated with a specific roller within the printer or the toner cartridge. Use figure 7-20 to isolate the cause of repetitive print defects. Align the first occurrence of the defect with the top of the “ruler” and measure to the next occurrence of the defect to determine the roller in question. When you are certain that your defect pattern matches the pattern of the ruler, replace the indicated roller.

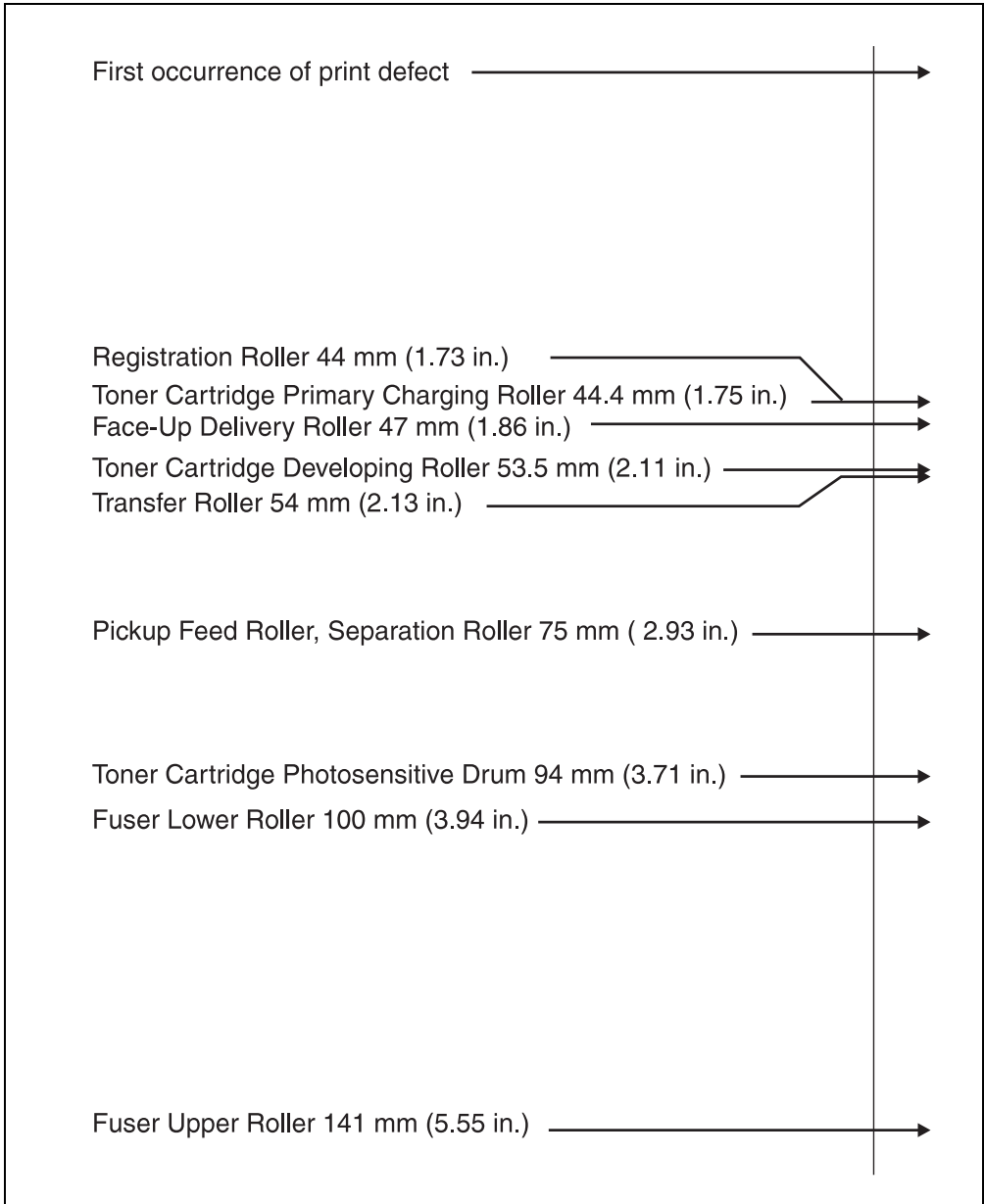

Figure 7-20 Repetitive Defect Ruler

Image System Troubleshooting

Half Self Test Functional Check

The electrophotographic process can be subdivided into the following stages:

- Cleaning (removing excess toner from drum surface)
- Conditioning (placing a uniform electrical charge on drum)
- Writing (laser strikes surface of drum to create latent image)
- Development (formation of the toner image on drum)
- Transfer (charge to transfer the image to paper)
- Fusing (heat and pressure to produce a permanent image)

See Chapter 5 for more information.

The purpose of the Half Self Test Check is to determine which process is malfunctioning. Perform the test as follows:

- 1 Print a Configuration Page. See “Configuration Pages” on page 589 for instructions.
- 2 Open the top cover after the paper advances half-way through the printer (about five seconds after the Main Motor begins rotating). The leading edge of the paper should have advanced past the toner cartridge.
- 3 Remove the toner cartridge.
- 4 Open the toner cartridge's drum shield to view the drum's surface.

If a *dark and distinct toner image is present* on the drum's surface, assume that the first four functions of the electrophotographic process are functioning (cleaning, conditioning, writing, and developing—see Chapter 5), and troubleshoot the failure as a transfer or fusing problem.

If *NO image is present* on the photosensitive drum, perform the functional checks on the following pages.

Drum Rotation Functional Check

The photosensitive drum, located in the toner cartridge, must rotate for the print process to work. The photosensitive drum receives its drive from the Main Drive assembly. To verify whether the drum is rotating:

- 1 Open the top cover.
- 2 Remove the toner cartridge.
- 3 Mark the cartridge's drive gear with a felt-tipped marker. Note the position of the mark.
- 4 Install the toner cartridge, and close the top cover. The start-up sequence should rotate the drum enough to move the mark.
- 5 Open the printer, and inspect the gear that was marked in step 3. Verify that the mark moved. If the mark did not move, inspect the Main Drive assembly to make sure that it is meshing with the toner cartridge gears. If the drive gears appear functional, and the drum does not move, replace the toner cartridge.

Note

This test is especially important if refilled toner cartridges have been used.

High-Voltage Power Supply Check

The High-Voltage Power Supply PCA provides the necessary voltages for the electrophotographic processes (see figure 7-21 on page 616). A method for verifying the high-voltage system is given below.

Toner cartridge connection points

Visually inspect the four connection points on the inside right end of the toner cartridge. If they are dirty or corroded, clean the connections. Clean using only alcohol. If damaged, replace the toner cartridge.

High voltage contacts

The high voltage contact springs mount on the High Voltage Power Supply PCA and protrude through the toner cartridge cavity to contact the toner cartridge. Verify that the contacts are not dirty or corroded and that the spring action is functional. If dirty, clean using only alcohol. If damaged, replace the High Voltage Power Supply PCA (see “High Voltage Power Supply (HVPS)” on page 269 for instructions).

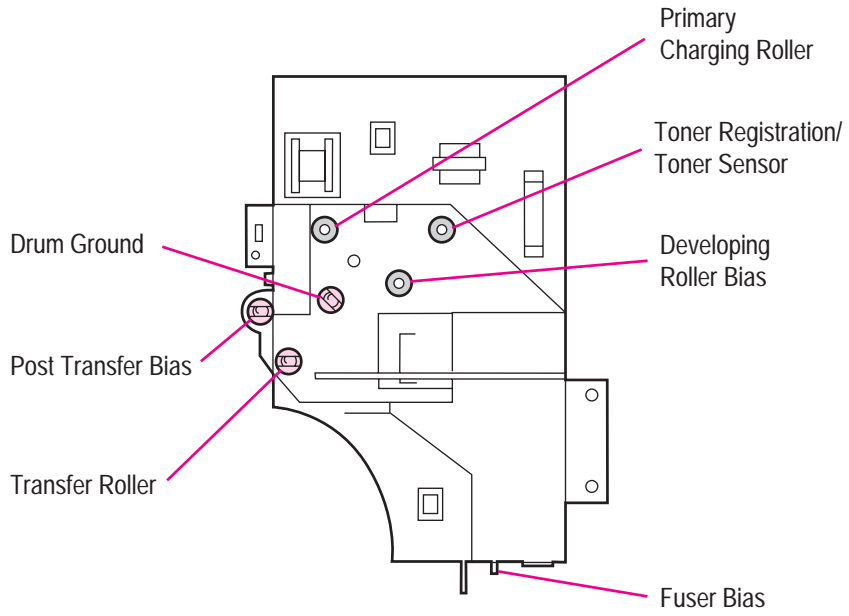

Figure 7-21 High Voltage Power Supply Contacts

Self-Diagnostics on Paper-handling Devices

2000-sheet Input Tray Stand-alone Diagnostics

The 2000-sheet Input Tray can run stand-alone diagnostic tests to test the device's motors, functionality, and sensors. You will need one power cord, one #2 Phillips screwdriver, and a small flat-blade screwdriver for the DIP switches.

2000-sheet Input Tray Motor Test

This test verifies that the three motors on the 2000-sheet Input Tray are functioning properly.

- 1 Identify the Back Cover (opposite from the tray door). Remove the four screws in the Back Cover. Remove the Back Cover (see "Back Cover" on page 219).
- 2 Pull open the paper tray, and open the Vertical Transfer Unit (VTU).
- 3 Set the DIP switches on the Controller PCA to Motor Test Mode. (See Table 7-34 on page 619 for an explanation of the DIP switch settings.)
- 4 To turn the Power Supply switch to Diagnostic Mode pull out on the blue handle.
 - If the motors are working properly, you will hear them as they rotate continuously.
 - If the motors do not rotate, replace the corresponding field-replaceable unit: either the Paper Pickup Assembly, the VTU, or the Paper Deck Drive Assembly.
- 5 To stop the test, set the power switch back to Operational Mode (push in), and reset the DIP switches on the Controller PCA to the off position (see Table 7-34 on page 619).

2000-sheet Input Tray Stand-alone Running Test

This test verifies that the 2000-sheet Input Tray is functioning properly. For this test, use the LED located on the Controller PCA on the 2000-sheet Input Tray. (See Table 7-35 on page 620 for an interpretation of the LED patterns.)

CAUTION

If the 2000-sheet Input Tray is setting underneath the printer, paper jams may occur because the printer will not pick up the paper. To prevent excessive paper jams during this test, feed only 6 to 8 pages.

- 1 Make sure that paper is in the tray.
- 2 Set the DIP switches on the Controller PCA for stand-alone running mode. (See Table 7-34 for an explanation of the settings).
- 3 To set the power supply switch to Diagnostic Mode, pull the blue power supply switch outward. The motors will start. Paper should now be lifted from the tray and fed through the VTU.
 - If the unit does not work properly, the lower Service LED on the Controller PCA flashes in a pattern that indicates the problem. (See Table 7-35 on page 620 for an interpretation of the LED patterns.)
- 4 To stop the test, set the power supply switch back to Operational Mode, and set the DIP switches on the Controller PCA to the off position (see Table 7-34). Open the VTU, and remove any media from the paper path.

2000-sheet Input Tray Sensor Test

This test manually activates the sensors on the 2000-sheet Input Tray to test if they are working properly.

- 1 Set the DIP switches on the Controller PCA for sensor test mode. (See Table 7-34 for an explanation of the settings.)
- 2 For each paper sensor:
 - a Pull open the paper tray, and open the VTU.
 - b Remove the metal spring that holds the sensor unit in place (secured by 1 screw). (See Figure 6-76, callouts 2 and 5.)
 - c Pull out the sensor unit.
- 3 To set the power supply switch to Diagnostic Mode, pull the blue power supply switch outward.
- 4 To manually activate each sensor, press it in with your finger.
 - When you activate the sensor, the bottom Service LED on the Controller PCA comes on. When you release the sensor, the LED goes off.
 - If the LED does not come on, there is a problem with the sensor. Replace the corresponding field-replaceable unit.
- 5 To stop the test, set the power supply switch back to Operational Mode, and set the DIP switches on the Controller PCA to the off position (see Table 7-34).

NORMAL SETTING	TEST SETTING
<input type="radio"/>	<input type="checkbox"/>
<input type="radio"/>	<input type="checkbox"/>
<input type="radio"/>	<input type="checkbox"/>
<input type="radio"/>	<input type="checkbox"/>
OFF POSITION	ON POSITION

Table 7-34. DIP Switch Settings

DIP Switch	Normal	Motor Test	Stand-alone Running Test	Sensor Test
1	Off	On	On	Off
2	Off	On	Off	Off
3	Off	Off	Off	On
4	Off	On	On	On

Note

Be sure to turn the power supply off and set all the DIP switches to the off position (normal settings) when you finish the diagnostics or the unit will not work properly. Then, replace the back cover.

2000-sheet Input Tray LED Status Interpretation

If the 2000-sheet Input Tray is working properly, it will pick up paper from the tray and feed it through the VTU, and the bottom Service LED will flash regularly every 0.5 seconds.

Table 7-35. 2000-sheet Input Tray LED Status Interpretation

Long (1 sec.)	Short (.03 sec.)	Error Number/ Meaning	Recommended Action
3	1	66.11.01 Lifter Malfunction	Lift the tray by hand to make sure that it lifts freely. Make sure that the paper size plates are correctly installed (in the same corresponding slots) and are not bent. If neither of these is the problem, replace Tray 4.
2	1	13.11.11 Registration Sensor Delay Jam	The media does not reach the sensor. Open the VTU door, and remove the media. Replace the VTU assembly or the paper pickup assembly.
2	2	13.11.3B Registration Sensor Station Jam/Initial Jam	Open the VTU door, and remove the media. Check the sensors, and replace the corresponding field-replaceable unit.
2	3	13.11.31 Jam Sensor Delay Jam	The media did not reach the sensor. Open the VTU door, and remove the media. Replace the VTU or the paper pickup assembly.
2	4	13.11.21 13.11.2B Jam Sensor Stationary Jam/Initial Jam	Open the VTU door and remove the media.
1	1	VTU Door Open	Close the door.
1	2	Paper Tray Open Wrong Size Paper Loaded.	Close the tray. Load the correct size of paper, or check the sensors.
1	3	No Paper in Tray	Load paper, or check the sensors.

Note

If the LED does not come on, replace the Paper Deck PCA or the Universal Power Supply Assembly.

2 x 500-sheet Input Tray Standalone Diagnostics

The standalone diagnostics are designed to test the 2 x 500-sheet Input Tray's motors, functionality, and sensors. You will need a power cord, a #2 Phillips screwdriver, and a small flatblade screwdriver for the DIP switches.

If the 2 x 500-sheet Input Tray is working properly, it picks paper up from the tray and feeds it into the VTU, while the bottom service LED flashes regularly every 0.5 seconds.

Note

To go from one test to another or to change the DIP switch settings, set the blue power supply switch to Operational Mode (push in). Reset the DIP switches on the Controller PCA, and then switch the power supply back to Diagnostic Mode (pull out) to enable the new diagnostic test. See figure 7-37 on page 624 for DIP switch settings.

2 x 500-sheet Input Tray Motor Test

This test verifies that the three motors on the 2 x 500-sheet Input Tray are functioning properly.

- 1 Identify the Back Cover (opposite side from tray door). Remove the 4 screws in the Back Cover. Remove the Back Cover.
- 2 Pull open Trays 4 and 5, and open the Vertical Transfer Unit (VTU).
- 3 Set the DIP switches on the Controller PCA to Motor Test Mode. (See table 7-6 on page 561 for an explanation of the DIP switch settings.)
- 4 To turn the power supply switch to Diagnostic Mode, pull out on the blue handle.
 - If the motors are working properly, you will hear them as they rotate continuously.
 - If the motors do not rotate, replace the corresponding field-replaceable unit: either the Paper Pickup Assembly, the VTU, or the Paper Deck Drive Assembly.
- 5 To stop the test, set the power supply switch back to Operational Mode (push in), and reset the DIP switches on the Controller PCA to the off position.

Table 7-36. DIP Switch Settings for troubleshooting test procedures

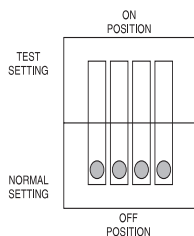

DIP Switch	Normal	Motor Test	Stand-alone Running Test	Sensor Test
1	Off	On	On	Off
2	Off	On	Off	Off
3	Off	Off	Off	On
4	Off	On	On	On

Note

The DIP switch is on if it is set to the top. The DIP switch is off if it is set to the bottom.

2 x 500-sheet Input Tray Standalone Running Test

This test verifies that the 2 x 500-sheet Input Tray is functioning properly. For this test, use the LED located on the Controller PCA. (See table 7-37 on page 624 for an interpretation of the LED patterns.)

CAUTION

If the 2 x 500-sheet Input Tray is underneath the printer, paper jams may occur because the printer will not pick up the paper. To prevent excessive paper jams during this test, feed only 6 to 8 pages.

- 1 Make sure that there is paper in both trays.
- 2 Set the DIP switches on the Controller PCA for standalone running mode. (See table 7-36 on page 622 for an explanation of the settings).
- 3 To test Tray 5, open Tray 4. To test Tray 4, open Tray 5.

- 4 To set the power supply switch to Diagnostic Mode, pull the blue power supply switch outward. The motors will start. Paper should now be lifted from the tray and fed through the VTU. The service LED flashes regularly every 0.5 seconds.
 - If the unit does not work properly, the service LED on the Controller PCA flashes in a pattern that indicates the problem. (See table 7-37 on page 624 for an interpretation of the LED patterns.)
- 5 To stop the test, set the power supply switch back to Operational Mode. Open the VTU, and remove any media from the paper path.
- 6 To test Tray 4, close Tray 4 and open Tray 5. Repeat step 4.
- 7 To stop the test, set the power supply switch back to Operational Mode, and set the DIP switches on the Controller PCA to the off position (see table 7-36 on page 622). Open the VTU, and remove any media from the paper path.

2 x 500-sheet Input Tray Sensor Test

Note

Be sure that trays 4 and 5 and the VTU are closed before starting the sensor test.

This test manually activates the sensors on the 2 x 500-sheet Input Tray to test if they are working properly.

- 1 Set the DIP switches on the Controller PCA for sensor test mode. (See table 7-6 on page 561 for an explanation of the settings.)
- 2 To set the power supply switch to Diagnostic Mode, pull the blue power supply switch outward.
- 3 To manually activate each sensor, press it in with your finger.
 - When you activate the sensor, the service LED on the Controller PCA comes on. When you release the sensor, the LED goes off.
 - If the LED does not come on, there is a problem with the sensor. Replace the corresponding field-replaceable unit.
- 4 To stop the test, set the power supply switch back to Operational Mode, and set the DIP switches on the Controller PCA to the off position (see table 7-6 on page 561).

Note

Be sure to turn the power supply off, and set all the DIP switches to the off position (normal settings) when you finish the diagnostics or the printer will not work properly. Replace the back cover.

2 x 500-sheet Input Tray LED Status Interpretation

If the 2 x 500-sheet Input Tray is working properly, it will pick up paper from the tray and feed it through the VTU and the bottom service LED will flash regularly every 0.5 seconds.

See page 561 for 2 x 500-sheet Input Tray error messages.

Table 7-37. Patterns of LED flashing (2-second pause between each pattern)

Long (1 sec)	Short (0.3 sec)	Error Number/ Meaning	Recommended Action
3	1	65.11.04 Lifter malfunction	Verify that the tray lifts up freely by lifting it by hand. Verify that the paper size plates are installed correctly (in the same corresponding slots) and are not bent. If neither of these is the problem, replace Tray 4 or 5.
2	1	13.11.11 Registration sensor delay jam	The media did not reach the sensor. Open the VTU door, and remove the media. Replace the paper feed (VTU) assembly or the paper pickup assembly.
2	2	13.11.31 Registration sensor stationary/jam initial jam	Open the VTU door, and remove the media. Check the sensors, and replace the corresponding field-replaceable unit.
2	3	13.11.1B Jam sensor delay jam	The media did not reach the sensor. Open the VTU door, and remove the media. Replace the paper feed (VTU) assembly or the paper pickup assembly.
2	4	13.11.3B Jam sensor stationary jam/initial jam	Open the VTU door, and remove the media.
1	1	The VTU door is open	Close the door.
1	2	Trays 4/5 are open Wrong paper size loaded	Close the tray(s). Check the sensors. Load the correct size of paper. Check the sensors.
1	3	No paper in trays 4/5	Load paper. Check the sensors.

Note

If the LEDs will not come on, replace the paper deck PCA or the universal power supply assembly.

7-bin Tabletop Mailbox Standalone Diagnostics

The standalone diagnostics are designed to test the device's motors, functionality, and sensors. You will need a power cord, a #2 Phillips screwdriver, and a small flatblade screwdriver for the DIP switches.

Note

To change from one test to another or change the DIP switch settings, push the blue power supply switch in (off position), then set to the new test positions.

- 1 To remove the back cover remove 2 screws (see page 352).
- 2 Identify the interlock switch. This black switch is set when the 7-bin Tabletop Mailbox comes into contact with the printer. (Look on opposite side from the paper trays.) This interlock can be defeated by holding it in with a finger or a piece of tape.
- 3 Identify the DIP switch, SW1 (upper-right corner of the controller PCA).
- 4 Identify the service LED, LED1 (near the C-link connectors).

Table 7-38. DIP switch settings for troubleshooting test

DIP Switch	Normal Settings	Motor Test	Standalone Running Test		Sensor Test
			Mailbox	Stacker	
1	Off	On	On	Off	Off
2	Off	On	Off	On	Off
3	Off	Off	On	Off	On
4	Off	On	Off	On	On

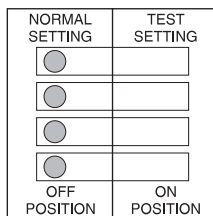

Note

The DIP switch is on if it is set to the right. The DIP switch is off if it is set to the left.

7-bin Tabletop Mailbox Motor Test

This test allows you to verify the functionality of the main motor, Face-down solenoid, and face-up diverter solenoid.

- 1 The top cover and paper access door must be closed to perform this test.
- 2 Set the DIP switches for the motor test (see table 7-38).
- 3 Pull out the power supply switch to the test position.
- 4 Press and hold in the interlock switch. A self-test should be performed, then the main motor will start moving continuously until the interlock switch is released. The service LED will flash every 0.5 seconds. If any other pattern results with the service LED, see table 7-39 on page 627 for the possible causes.
- 5 Push in the power supply switch to the normal position.

7-bin Tabletop Mailbox Standalone Running Test

This test allows you to feed paper into the unit to test the paper path without a connection to the printer. You can configure either the Mailbox Mode or the Stacker Mode to ensure the paper path is working properly.

- 1 The top cover and paper access door must be closed to perform this test.
- 2 Set the DIP switches for the standalone running test in either Mailbox Mode or the Stacker Mode (see table 7-38 on page 625).
- 3 Pull out the power supply switch to the test position.
- 4 Press and hold in the interlock switch. Perform a self-test. Then manually start feeding paper.
 - In Mailbox Mode, the unit will deliver paper to all bins, starting with the Face-up Bin, then down to the bottom bin.
 - In Stacker Mode, the unit will stack paper starting at the bottom bin until the top-of-stack is reached on each bin.
- 5 If problems are found, the possible cause will be indicated by the Service LED (see table 7-39 on page 627).
- 6 Push in the power supply switch to the normal position.

7-bin Tabletop Mailbox Sensor Test

This test allows you to check if all unit sensors are working properly. By activating any unit sensor flag, the service LED should turn on.

- 1 Make sure that all bins are empty to perform the sensor test.
- 2 Set the DIP switches for the sensor test (see table 7-38 on page 625).
- 3 Do NOT press the interlock switch in at this time.
- 4 Pull out the power supply switch to the test position.
- 5 Make sure that the service LED is off.
- 6 Manually activate any sensor flag. The service LED should turn on if the sensor is functional.

Note

To test the top cover or paper access door sensors, you need to press the interlock switch and simultaneously open and close each cover. A self-test should be performed, and the LED should remain on.

To test the bin full sensors, press the sensor in the paper tray closest to the back of the 7-bin Tabletop Mailbox (on your left as you face the bins). The test will not work if you press the sensor closest to the front of the device.

CAUTION

Be sure to turn the power supply off and set all the DIP switches to the off position (normal settings) when you finish the diagnostics or the printer will not work properly. Replace the back cover.

See page 565 for 7-bin Tabletop Mailbox error messages.

Table 7-39. Patterns of Flashing LEDs

Long	Short	Error Number/ Meaning	Recommended Action
3	1	66.12.16 66.22.16 Paper exit solenoid malfunction	<ul style="list-style-type: none">● Perform the motor test to check the solenoids.● Perform the sensor test.● Replace the sensor bin full PCA, solenoids, or controller board.
2	1	13.12.31 13.22.31 Initial jam	<ul style="list-style-type: none">● Open the top cover and paper access door to remove any remaining paper, then perform a sensor test.● Replace the sensor bin full PCA or controller PCA.

Table 7-39. Patterns of Flashing LEDs (continued)

Long	Short	Error Number/ Meaning	Recommended Action
2	2	13.12.01 13.22.01 Jam without delivery notice	<ul style="list-style-type: none"> ● Open all covers and doors in the device, and remove any jammed paper. ● Check for paper jammed in the printer. ● Try printing again.
2	3	13.12.11 13.22.11 Entry sensor delay	<ul style="list-style-type: none"> ● Open all covers and doors in the device, and remove any remaining media. ● Check each output bin.
2	5	13.12.17 13.22.17 Face-up sensor delay	<ul style="list-style-type: none"> ● Perform a sensor check. ● Check the sensor flag, the optical sensor, or cabling.
2	7	Reversing area delay	<ul style="list-style-type: none"> ● Replace the sensor PCAs. ● Replace the controller PCA.
2	9	13.12.15 13.22.15 Vertical sensor delay	
2	4	13.12.21 13.22.21 Entry sensor activated too long	<ul style="list-style-type: none"> ● Open the top and back covers, and remove any remaining media. ● Check each output bin. ● Perform a sensor check.
2	6	13.12.27 13.22.27 Face-up sensor activated too long	<ul style="list-style-type: none"> ● Check the sensor flag, the optical sensor, or cabling. ● Replace the sensor PCAs. ● Replace the controller PCA.
2	8	13.12.21 13.22.21 13.12.27 13.22.27 Reversing area sensor activated too long	
2	10	13.12.22 13.22.22 13.12.25 13.22.25 Vertical sensor activated too long	
1	1	Door open or interlock switch deactivated	<ul style="list-style-type: none"> ● Close the top cover and paper access door. ● Firmly attach the 7-bin Tabletop Mailbox to the printer. ● Perform a sensor check. ● Check the bin full and interlock sensor PCA, cabling, and controller PCA.

Table 7-39. Patterns of Flashing LEDs (continued)

Long	Short	Error Number/ Meaning	Recommended Action
1	2	Bin full when running the standalone test	● Remove paper from all the bins.

8-bin Mailbox Stand-alone Diagnostics

The stand-alone diagnostics are designed to test the device's motors and functionality without connection to the printer. Note that the diagnostics do not test the functionality of the stapler. You will need one power cord and a small flat-blade screwdriver for the power supply switch.

8-bin Mailbox LEDs Description

The 8-bin Mailbox has two sets of LEDs:

- **User LED.** The first is a single LED located on the right side of the top cover (Figure 7-22, callout 1). This User LED provides information to the end user about the 8-bin Mailbox power-on status and the attachment and alignment to the printer.
- **Service LEDs.** The second set is formed by three independent LEDs located in the middle of the left side cover (Figure 7-22, callout 2). This group is called the Service LEDs, and they show additional technical information to decode the 8-bin Mailbox status.

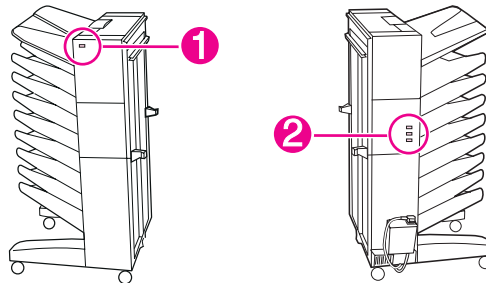

Figure 7-22 8-bin Mailbox LEDs Description

8-bin Mailbox Stand-alone Diagnostic Test

Each time you run the stand-alone diagnostic test, proceed as follows:

- 1 Turn off the printer, and pull the 8-bin Mailbox away from the printer.
- 2 With the 8-bin Mailbox unplugged, configure the power supply switch to the test mode by sliding the power supply switch up with a small flat-blade screwdriver (Figure 7-23, callout 1).



Figure 7-23 8-bin Mailbox Power Supply Test Mode Switch

- 1 Plug in the power cord. The User LED should be solid green, and the Service LEDs should be 'Off, Solid Red, Off' to indicate the test mode has been entered.

Note

Be sure to reset the power supply switch to the normal operation when you finish the diagnostics; otherwise the unit will not work properly.

Power-on Test

- 1 Push the 8-bin Mailbox interlock switch and keep it pressed. A sequence of tests will begin to test the device.
- 2 The head assembly will move up and down twice, scanning that all unit bins are properly installed and that all unit motors have started.
- 3 At the end of the power-on test, the flipper motor remains on and waits for paper to be fed.
- 4 The User LED remains solid green and the service LEDs remain 'Off, Solid Red, Off' as an indication that the power-on test was successful.
- 5 If a problem exists, an error code will be shown in the Service LEDs. (See table 3-3 for an interpretation of the LEDs.)

8-bin Mailbox Paper Path Test

- 1 If the power-on test is successful, then manually feed paper through the input paper guide in the horizontal position.
- 2 The paper will pass across the flipper assembly and move down to the bottom bin by the double belt system through the head assembly.
- 3 If after feeding several pages the paper path test is successful, then reattach the 8-bin Mailbox to the printer.
- 4 If a problem exists, an error code will be shown in the Service LEDs. (See table 7-40 for an interpretation of the LEDs.)

Note

Be sure to reset the power supply switch to the normal operation when you finish the diagnostics; otherwise the unit will not work properly.

8-bin Mailbox LEDs Status Interpretation

Table 7-40. 8-bin Mailbox LED Status Interpretation

Message Description/Number	User LED	Service LEDs	Recommended Action
<div style="display: flex; justify-content: space-between;"> <div style="width: 45%;"> <p>● solid green</p> <p>○ solid amber</p> <p>● blinking amber</p> </div> <div style="width: 45%;"> <p>● solid red</p> <p>○ blinking red</p> <p>○ blank</p> </div> </div>			
<p>MBM Ready The 8-bin Mailbox was successfully connected and initialized by the printer.</p>	●	○ ○ ○	No action required.
<p>PowerSave Mode The 8-bin Mailbox is in PowerSave mode.</p>	●	○ ○ ●	No action required.
<p>Self-test Mode The 8-bin Mailbox is in test mode.</p>	●	○ ● ○	<ul style="list-style-type: none"> ● Run the power-on test. ● Run the paper path test.
<p>MBM Unlatched from the Printer The 8-bin Mailbox is not properly attached to the printer.</p>	●	○ ○ ○	<ul style="list-style-type: none"> ● Check for proper alignment. ● Check the attachment clips. ● Check the Adjustable Casters. ● Check the Interlock Switch.
<p>Face-up Bin is Too Full The Face-up Bin has too much paper and it has reached the PSFaceUp flat, avoiding the flipping operation.</p> <p>65.12.01 65.22.01</p>	●	○ ○ ○	<ul style="list-style-type: none"> ● Remove the paper from the Face-up Bin. ● Check for a stuck Sensor Flag. ● Replace the Flipper Assembly. ● Check for the proper cable connections.

Table 7-40. 8-bin Mailbox LED Status Interpretation (continued)

Message Description/Number	User LED	Service LEDs	Recommended Action
<div style="display: flex; justify-content: space-between;"> <div style="width: 45%;"> <p>● solid green</p> <p>○ solid amber</p> <p>● blinking amber</p> </div> <div style="width: 45%;"> <p>● solid red</p> <p>○ blinking red</p> <p>○ blank</p> </div> </div>			
<p>Jam in Flipper Area A time-out condition occurred at the entry area.</p> <p>13.12.02 13.22.02 65.12.01 65.22.01</p>	<p>●</p>	<p>○</p> <p>○</p> <p>○</p>	<ul style="list-style-type: none"> ● Open the Jam Access Door, and check for a paper jam or an out-of-place Flipper Assembly shaft. ● Check for a stuck paper sensor. ● Replace the Flipper Assembly. ● Replace the 8-bin Mailbox PCA.
<p>Jam in Belt A time-out condition occurred in the Transport Belt.</p> <p>13.12.03 13.22.03</p>	<p>●</p>	<p>○</p> <p>○</p> <p>○</p>	<ul style="list-style-type: none"> ● Check for paper jammed at the Transport Belt System/ Delivery Head Assembly. ● Make sure that the Transport Belt (both belts) move freely. ● Make sure that the belts are parallel in the Transport Belt system. ● Make sure that the Metal Tape is in place and in good condition. ● Replace the Transport Belt Motor. ● Replace the 8-bin Mailbox PCA. ● Replace the Delivery Head Assembly.

Table 7-40. 8-bin Mailbox LED Status Interpretation (continued)

Message Description/Number	User LED	Service LEDs	Recommended Action
<div style="display: flex; justify-content: space-between;"> <div style="width: 45%;"> <p>● solid green</p> <p>○ solid amber</p> <p>● blinking amber</p> </div> <div style="width: 45%;"> <p>● solid red</p> <p>○ blinking red</p> <p>○ blank</p> </div> </div>			
<p>Jam in Delivery Head Assembly A time-out condition occurred in the PSExit1 sensor.</p> <p>13.12.05 13.22.05</p>	<p>●</p>	<p>○</p> <p>○</p> <p>○</p>	<ul style="list-style-type: none"> ● Check for paper jammed in the Delivery Head Assembly. ● Make sure that both the PSExit1 and PSExit2 sensors on the Delivery Head Assembly move freely. ● Make sure that the fingers are over the Ejector Rollers on the Delivery Head Assembly. ● Replace the flat ribbon cable that connects to the Delivery Head Assembly. ● Replace the Delivery Head Assembly. ● Replace the 8-bin Mailbox PCA.

Table 7-40. 8-bin Mailbox LED Status Interpretation (continued)

Message Description/Number	User LED	Service LEDs	Recommended Action
<div style="display: flex; justify-content: space-between;"> <div style="width: 45%;"> <p>● solid green</p> <p>○ solid amber</p> <p>● blinking amber</p> </div> <div style="width: 45%;"> <p>● solid red</p> <p>○ blinking red</p> <p>○ blank</p> </div> </div>			
<p>Jam in the Delivery Head Position System The elevator motor detected an invalid window when scanning.</p> <p>13.12.06 13.22.06 65.12.03 65.22.03 65.12.03 65.22.03</p>	<p>●</p>	<p>○</p> <p>○</p> <p>○</p>	<ul style="list-style-type: none"> ● Make sure that the Blind Cover and Scan Bar are installed properly. ● Check for paper jammed in the Transport Belt System and the Delivery Head Assembly. ● Make sure that the Delivery Head Assembly (up and down) moves freely. ● Make sure that all paper bins are seated correctly. ● Make sure that the paper bins and the Blind Cover are not broken. ● Replace the Delivery Head Position Motor. ● Replace the Delivery Head Assembly. ● Replace the 8-bin Mailbox PCA.
<p>Slider Problem at the Head Assembly The sliders do not activate the slider photosensor.</p> <p>65.12.04 65.22.04</p>	<p>●</p>	<p>○</p> <p>○</p> <p>○</p>	<ul style="list-style-type: none"> ● Check for paper jammed in the Delivery Head Assembly. ● Make sure that all the paper bins are seated correctly. ● Replace the Delivery Head Assembly.

Table 7-40. 8-bin Mailbox LED Status Interpretation (continued)

Message Description/Number	User LED	Service LEDs	Recommended Action
<div style="display: flex; justify-content: space-between;"> <div style="width: 45%;"> <p>● solid green</p> <p>○ solid amber</p> <p>● blinking amber</p> </div> <div style="width: 45%;"> <p>● solid red</p> <p>○ blinking red</p> <p>○ blank</p> </div> </div>			
<p>Wrong Page Request A page request was received with an invalid output bin or invalid paper size information.</p> <p>13.12.0A 13.22.0A</p>	●	○ ○ ○	<ul style="list-style-type: none"> ● Check the bin destination. ● Check the paper size configuration. ● Turn on the printer.
<p>Flipper Error During the flipper calibration, an abnormal reference voltage was encountered.</p> <p>66.12.08 66.22.08</p>	○	○ ○ ●	<ul style="list-style-type: none"> ● Check for paper jammed in the Flipper Assembly area. ● Check the cable connections. ● Replace the Flipper Assembly. ● Replace the 8-bin Mailbox PCA.
<p>External Memory Error The 8-bin Mailbox's nonvolatile RAM (NVRAM) is damaged.</p> <p>66.12.09 66.22.09</p>	○	○ ● ●	<ul style="list-style-type: none"> ● Replace the 8-bin Mailbox PCA.

Diagrams

This section contains the following diagrams:

- Figure 7-24, “Printer Sensors and Switches,” on page 639
- Figure 7-25, “Printer Motor, Clutches, and Solenoids,” on page 640
- Figure 7-26, “DC Controller Inputs and Outputs (1 of 5),” on page 641
- Figure 7-27, “DC Controller Inputs and Outputs (2 of 5),” on page 642
- Figure 7-28, “DC Controller Inputs and Outputs (3 of 5),” on page 643
- Figure 7-29, “DC Controller Inputs and Outputs (4 of 5),” on page 644
- Figure 7-30, “DC Controller Inputs and Outputs (5 of 5),” on page 645
- Figure 7-31, “Mailbox with Stapler Wiring Diagram,” on page 646
- Figure 7-32, “2000-sheet Input Tray Controller PCA Inputs,” on page 647
- Figure 7-33, “2000-sheet Input Tray Controller PCA Outputs,” on page 648
- Figure 7-34, “2000-sheet Input Tray Main Wiring Diagram,” on page 649
- Figure 7-35, “8-bin Mailbox Main Wiring Diagram,” on page 650
- The main wiring diagram is inserted inside the cover.

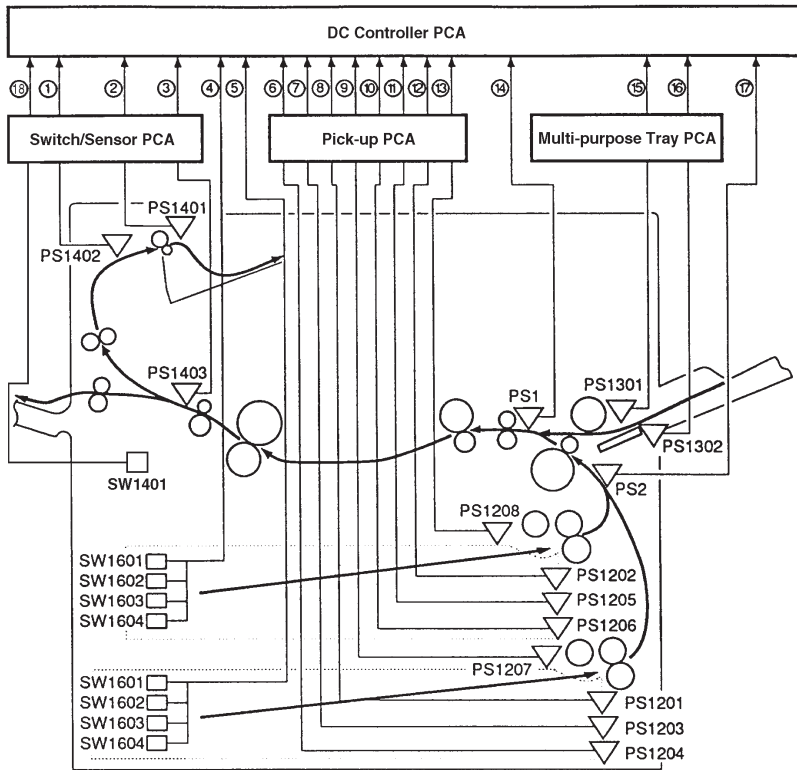

- | | |
|--|--|
| <ul style="list-style-type: none"> ① : FACE-DOWN TRAY DELIVERY SENSE signal (/FDOUTS) ② : FACE-DOWN TRAY PAPER FULL SENSE signal (/FDDULS) ③ : FUSING UNIT DELIVERY SENSE signal (FPOUTS) ④ : TRAY 2 PAPER SIZE SENSE signal ⑤ : TRAY 3 PAPER SIZE SENSE signal ⑥ : TRAY 3 PAPER-LEVEL SENSE signal 1 (LVPS1) ⑦ : TRAY 3 PAPER-LEVEL SENSE signal 2 (LVPS2) ⑧ : TRAY 3 SENSE signal (/LDECKC) ⑨ : TRAY 3 PAPER-OUT SENSE signal (/LDECKS) ⑩ : TRAY 2 PAPER-LEVEL SENSE signal 1 (UPVS1) ⑪ : TRAY 2 PAPER-LEVEL SENSE signal 2 (UPVS2) ⑫ : TRAY 2 SENSE signal (/UDECKC) ⑬ : TRAY 2 PAPER-OUT SENSE signal (/UDECKS) ⑭ : REGISTRATION PAPER SENSE signal (/REGS) ⑮ : TRAY 1 PAPER SENSE signal (/MPTPS) ⑯ : LIFTING PLATE SENSE signal (/MPTLS) ⑰ : PICK-UP UNIT PAPER SENSE signal (/FEEDS) ⑱ : TOP/LEFT DOOR OPEN signal (UDOORS) | <ul style="list-style-type: none"> PS1: Registration paper sensor PS2: Pick-up unit paper sensor PS1201: Tray 3 present sensor PS1202: Tray 2 present sensor PS1203: Tray 3 paper-level sensor 1 PS1204: Tray 3 paper-level sensor 2 PS1205: Tray 2 paper-level sensor 1 PS1206: Tray 2 paper-level sensor 2 PS1207: Tray 3 paper-out sensor PS1208: Tray 2 paper-out sensor PS1301: Tray 1 paper present sensor PS1302: Lifting plate position sensor PS1401: Face-down tray paper full sensor PS1402: Face-down tray delivery sensor PS1403: Fixing unit delivery sensor SW1601: Paper-size sensing switch SW1602: Paper-size sensing switch SW1603: Paper-size sensing switch SW1604: Paper-size sensing switch SW1401: Doors open switch |
|--|--|

Figure 7-24 Printer Sensors and Switches

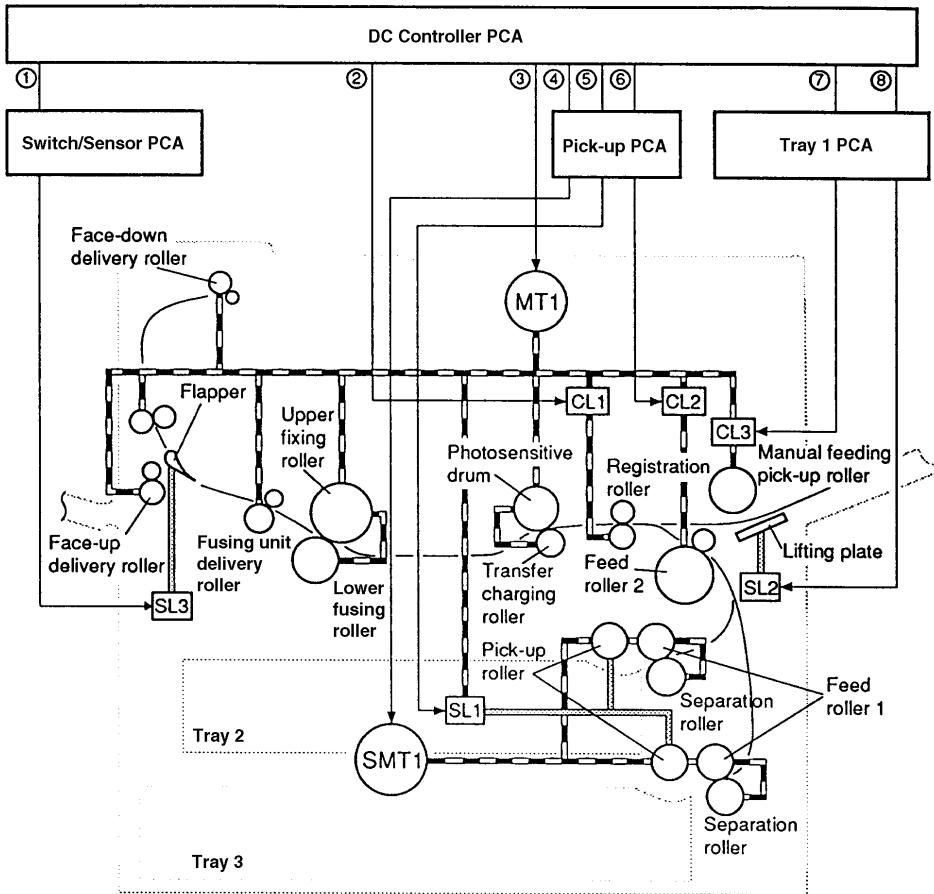

Figure 7-25 Printer Motor, Clutches, and Solenoids

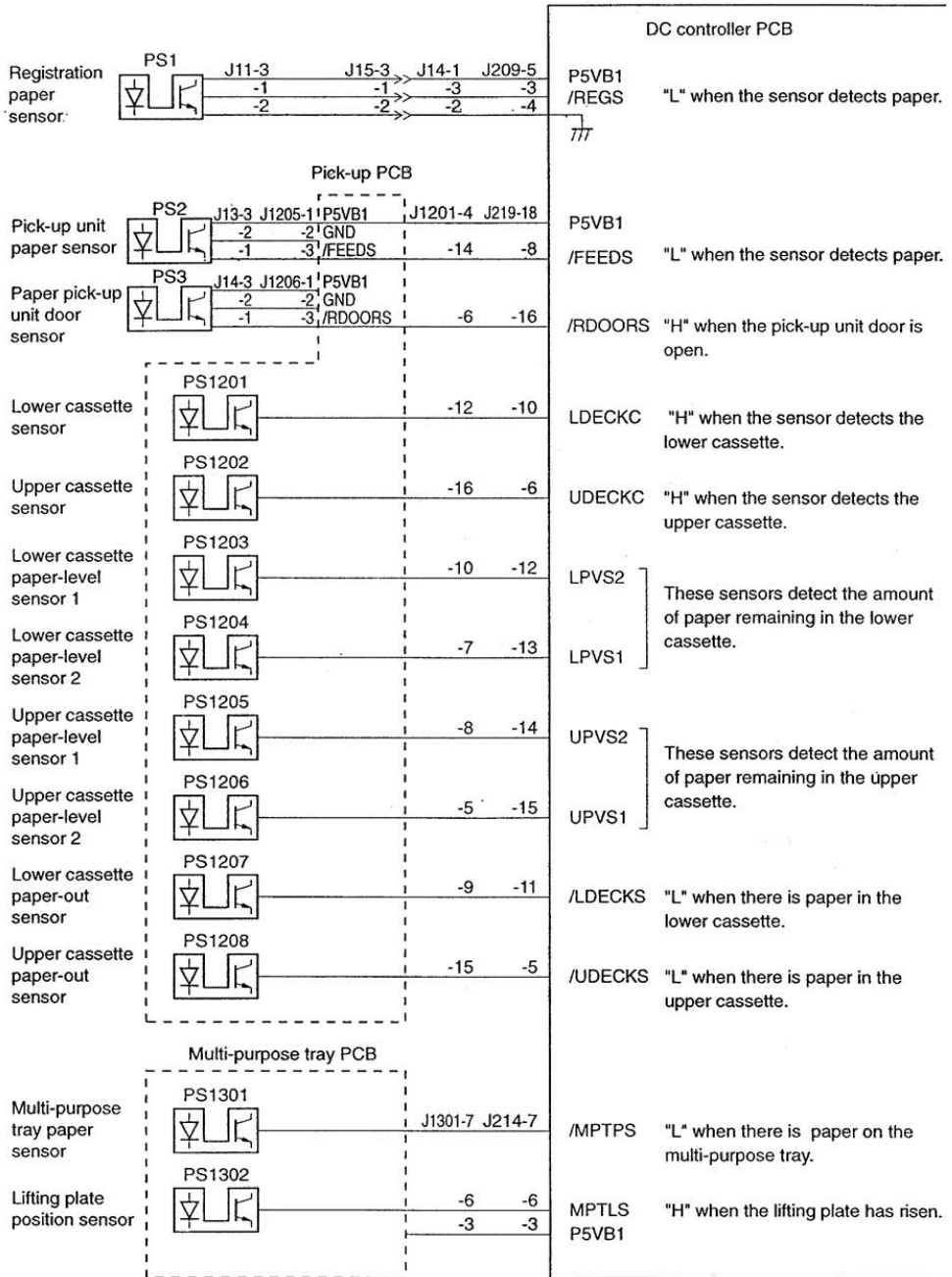

Figure 7-26 DC Controller Inputs and Outputs (1 of 5)

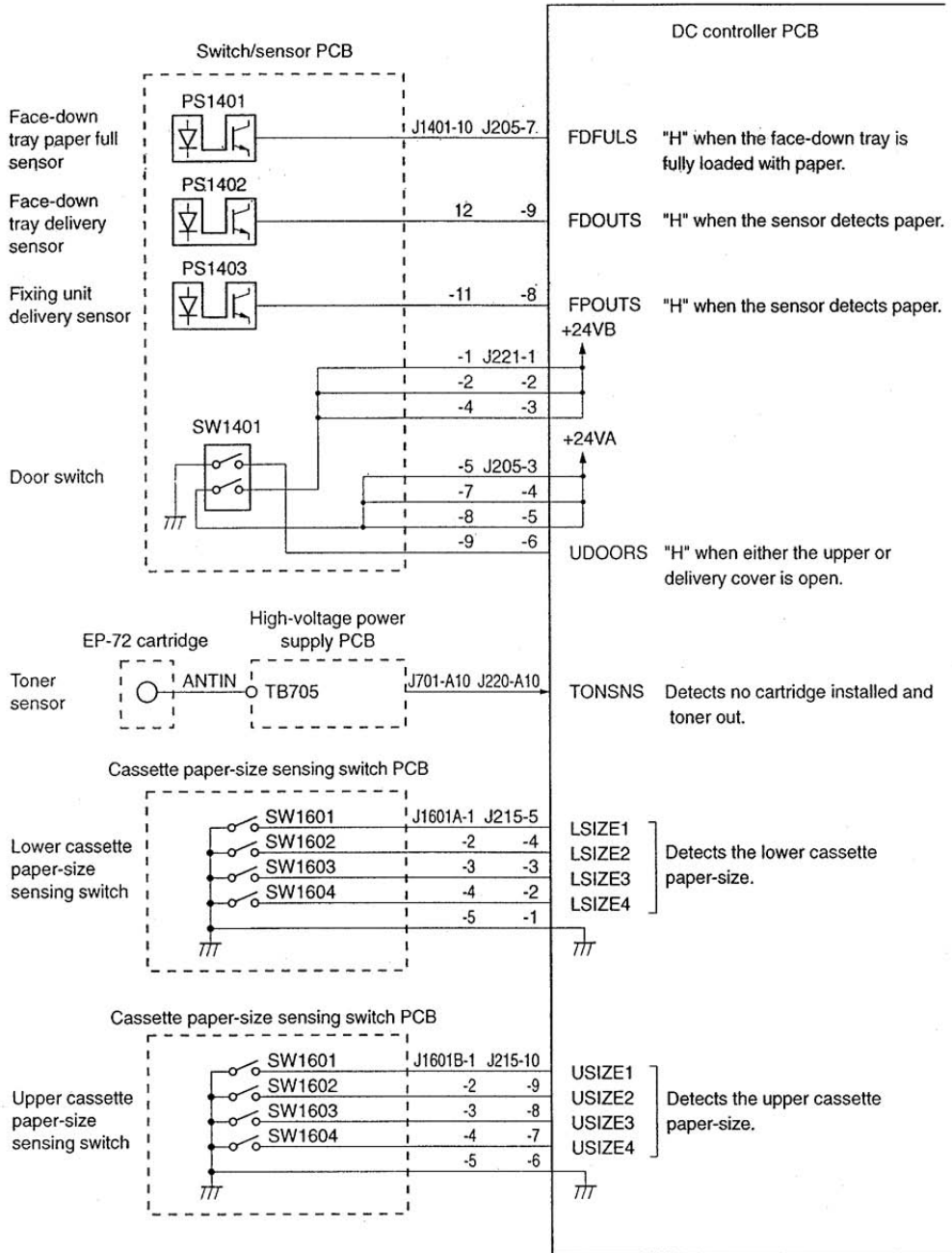

Figure 7-27 DC Controller Inputs and Outputs (2 of 5)

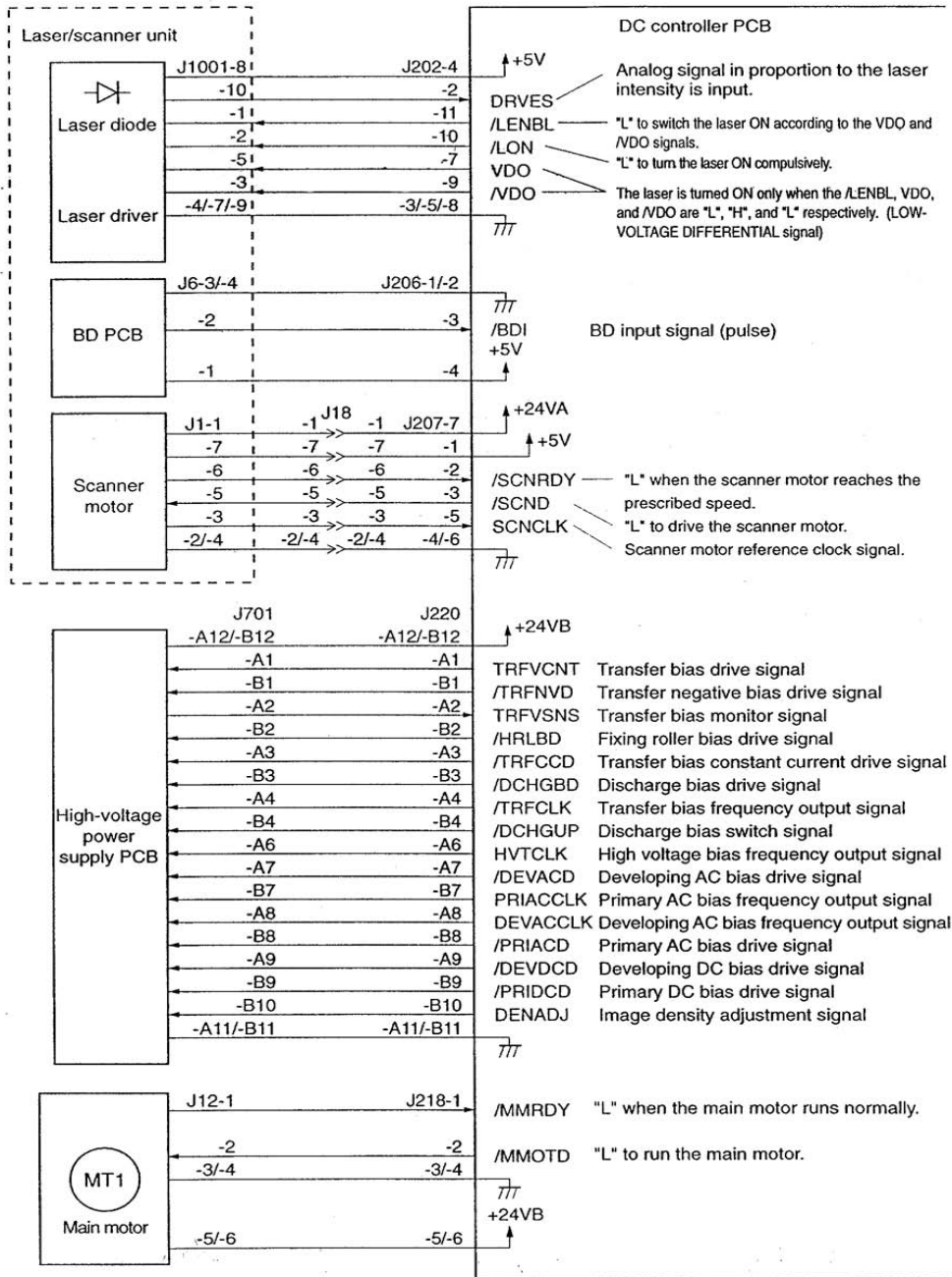

Figure 7-28 DC Controller Inputs and Outputs (3 of 5)

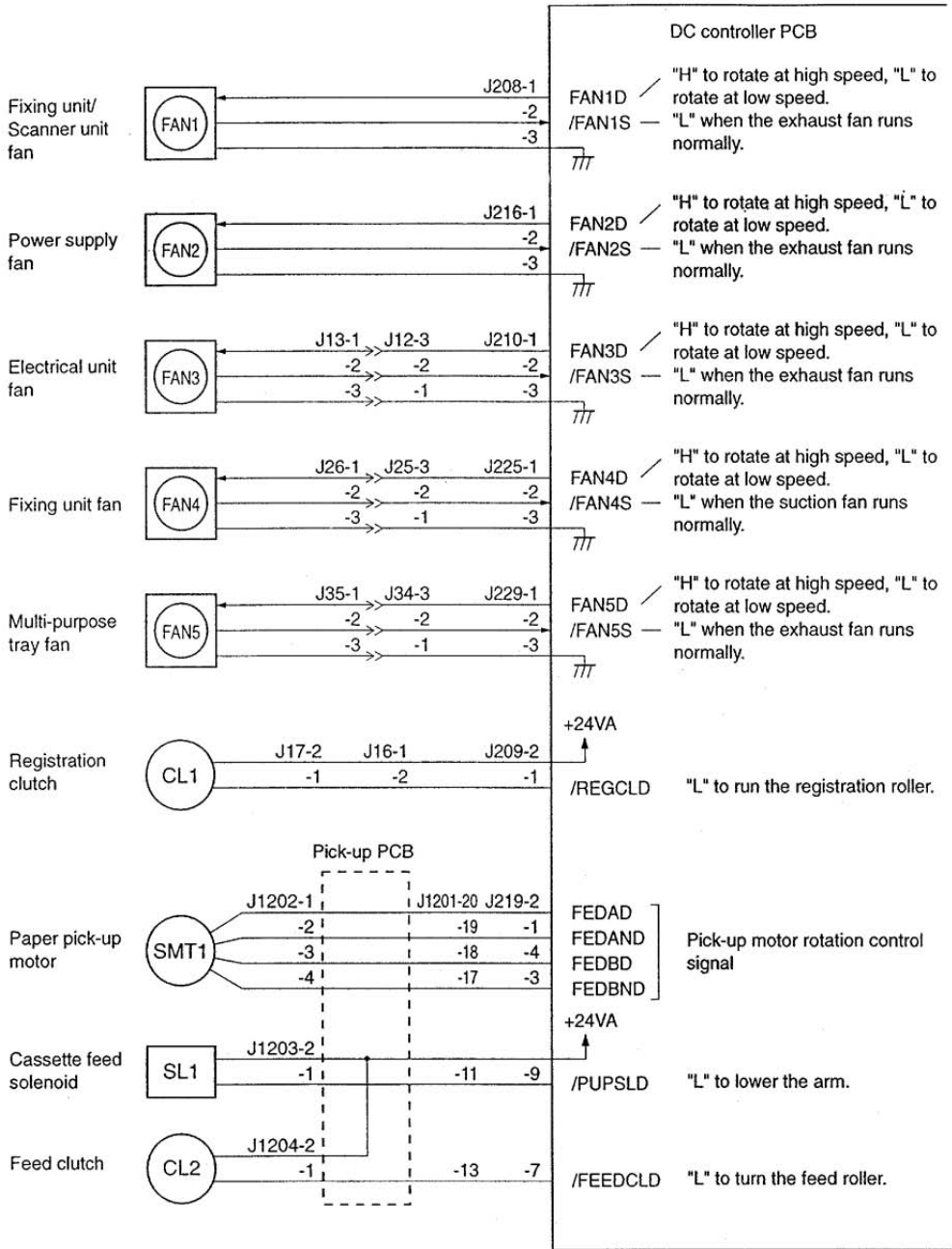

Figure 7-29 DC Controller Inputs and Outputs (4 of 5)

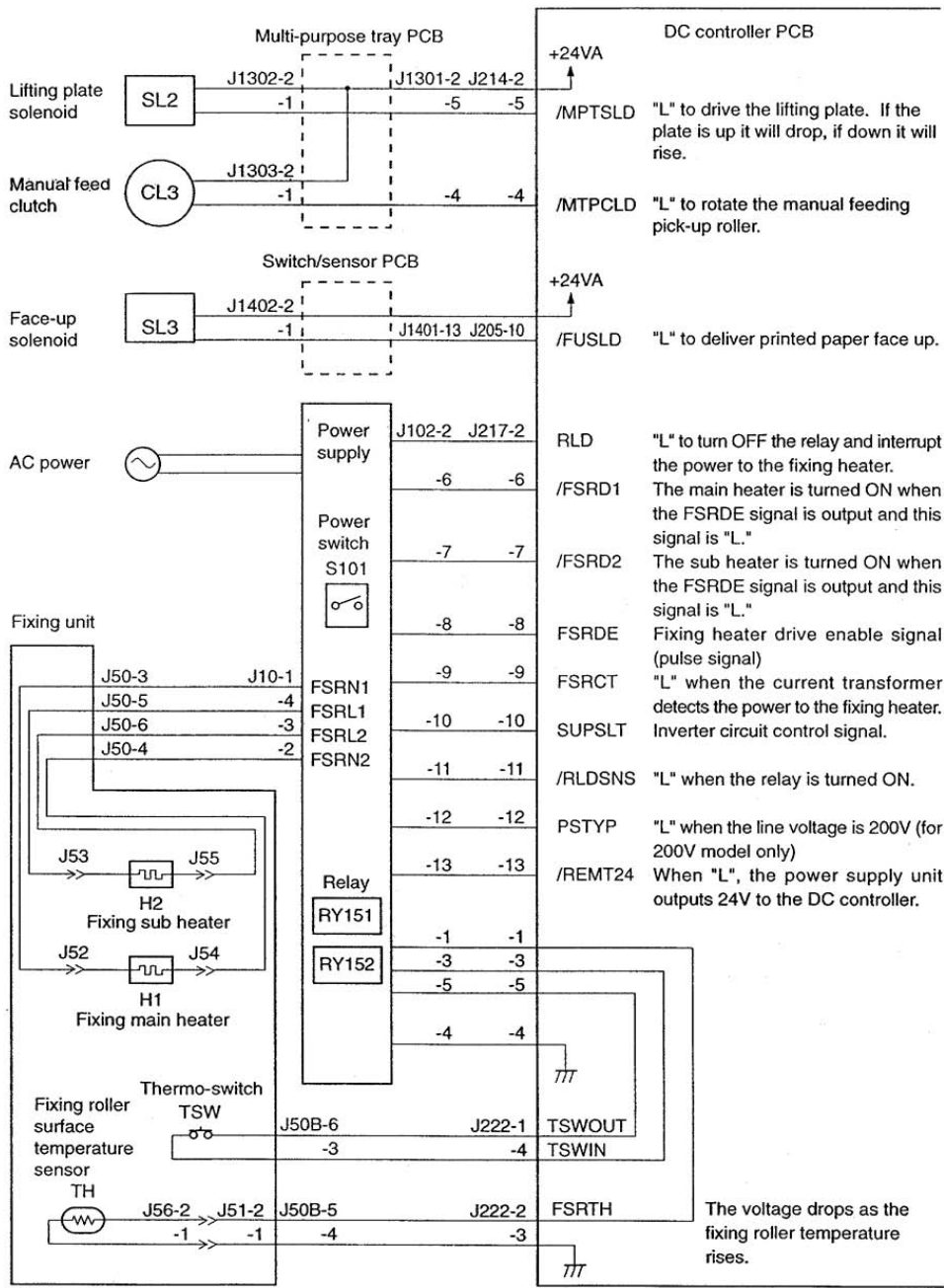

Figure 7-30 DC Controller Inputs and Outputs (5 of 5)

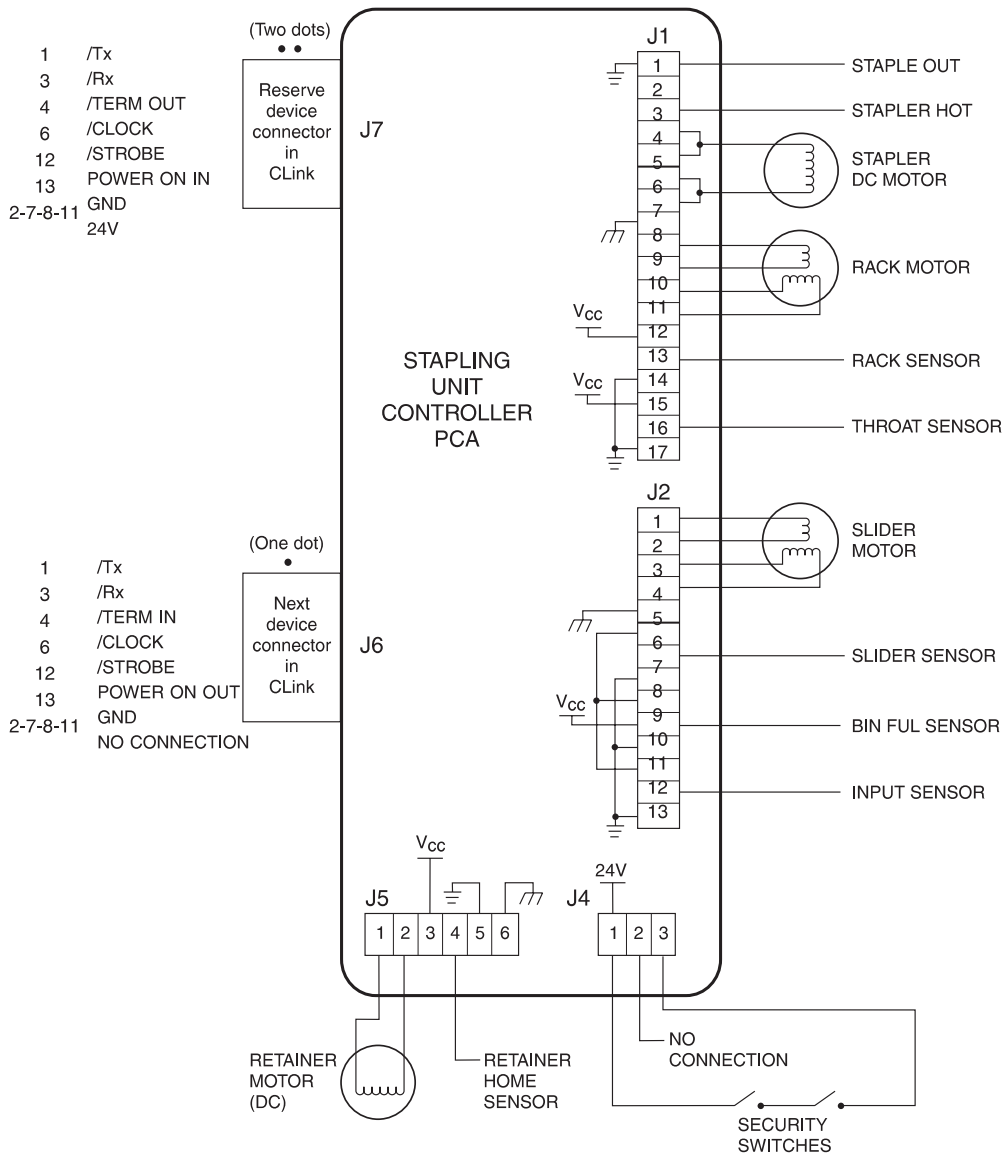

Figure 7-31 Mailbox with Stapler Wiring Diagram

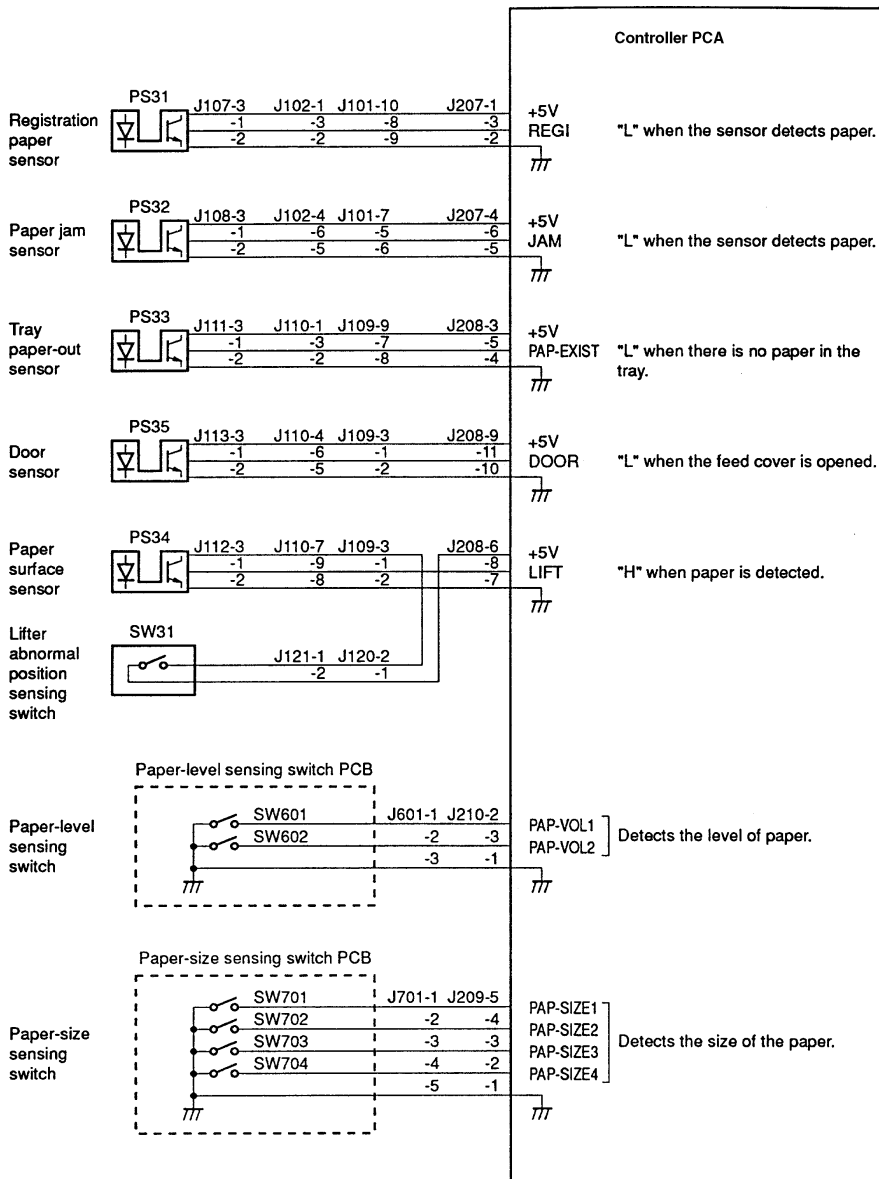

Figure 7-32 2000-sheet Input Tray Controller PCA Inputs

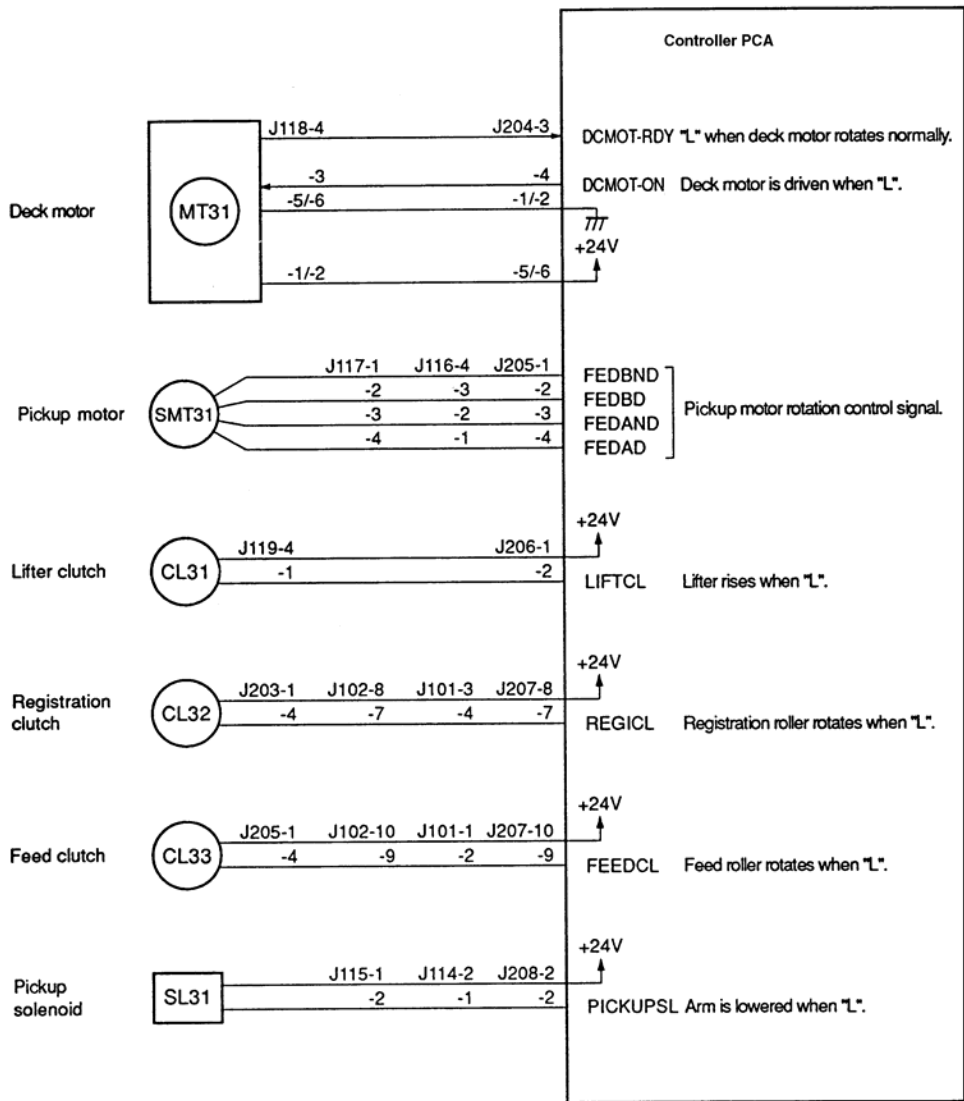

Figure 7-33 2000-sheet Input Tray Controller PCA Outputs

2000-SHEET INPUT TRAY CONTROLLER PCA

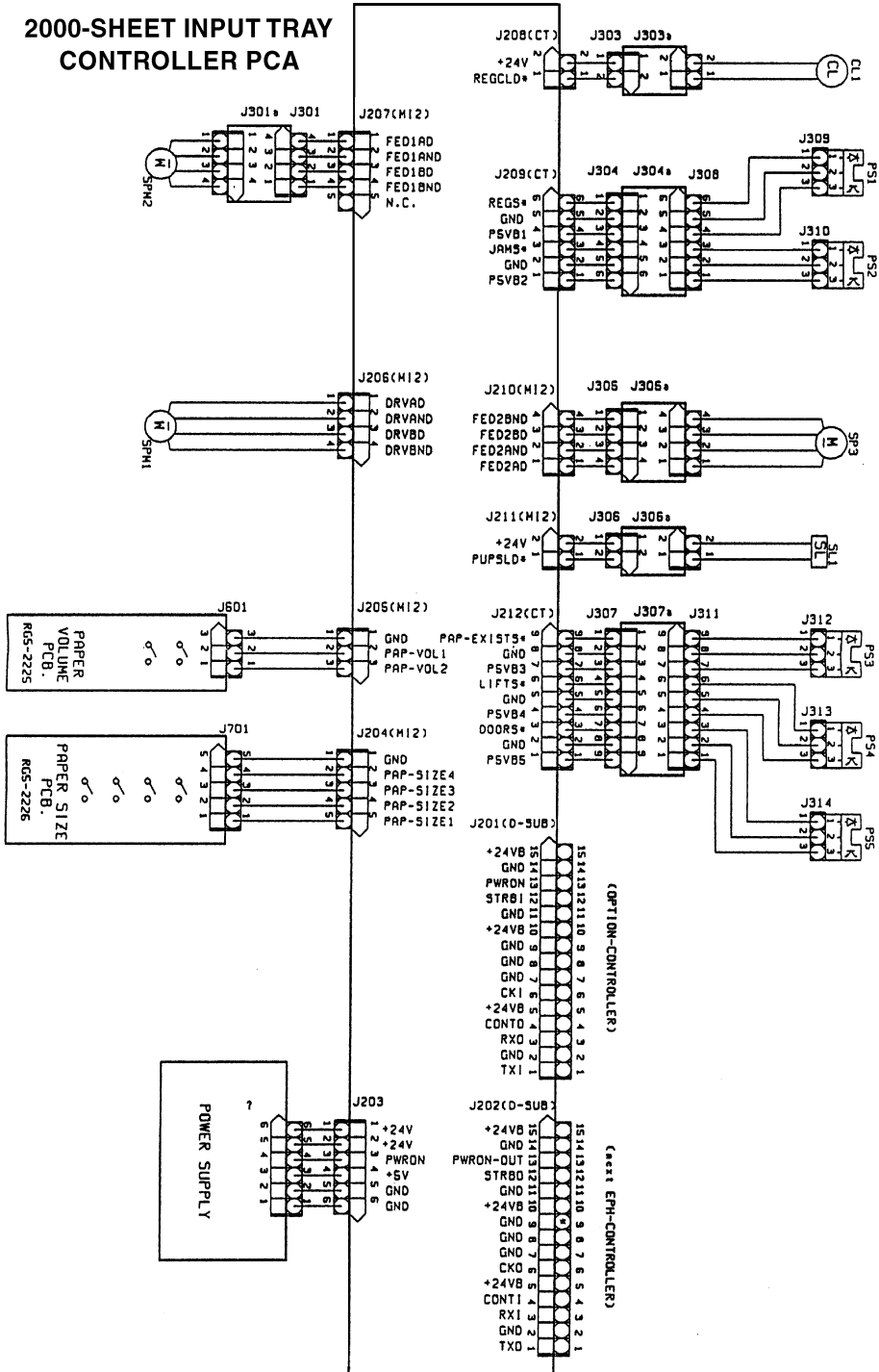

Figure 7-34 2000-sheet Input Tray Main Wiring Diagram

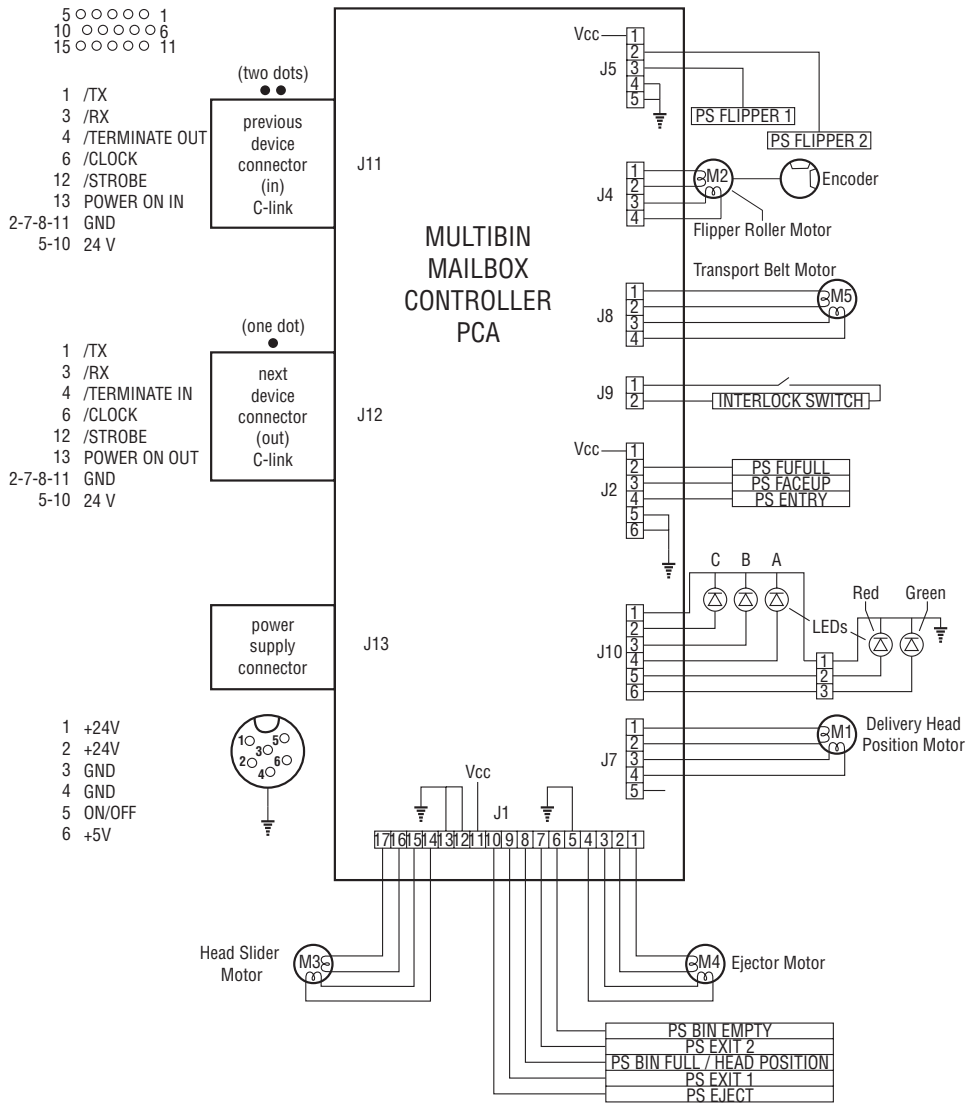

Figure 7-35 8-bin Mailbox Main Wiring Diagram

Troubleshooting the HP Digital Copy 320

This section deals with troubleshooting procedures specific to the HP Digital Copy 320. For a general troubleshooting approach, see the flowcharts starting on page 517. The steps for troubleshooting the HP Digital Copy 320 are as follows:

- ▼ Step 1: Power On (page 652)
- ▼ Step 2: Display and Communication (page 653)
- ▼ Step 3: Error Messages and Problems (page 654)
- ▼ Step 4: Information Pages (page 659)
- ▼ Step 5: Paper Path (page 660)
- Step 6: Image Quality (page 661)

Step 1 Power On

Is the copy module on and displaying anything on the Front Panel?
(YES = Go to Step 2: Display and Communication)

Table 7-41. Power On Checks

Check	Recommended Action
Is the host Mopier on and functioning correctly?	<ul style="list-style-type: none">● Make sure both the Mopier and copy module power switches are set to the on position.● Ensure the Mopier and copy module are not in power save mode. Press any key on the front panel.● Eliminate paper-handling devices as a cause of the problem.● Troubleshoot the Mopier. See page 534.
Is AC power available to the Mopier System?	<ul style="list-style-type: none">● Check power to the Mopier's power receptacle.● Make sure power is cabled correctly to provide AC power to the copy module. (See "Install the Y Power Cord" on page 436 for y cable descriptions.)● To test power, plug in the copy module directly.● Plug in a known working device to test the outlet.
Is the copy module's fan working?	<ul style="list-style-type: none">● If the fan is running, the copy module power supply and Control PCA are probably OK.● Disconnect the copy connect cable to the Mopier and plug in the Copy Module directly to the AC outlet. The copy module should boot to the second icon and stop.● If the fan still does not run check its connection to the Control PCA. If the connection is OK, suspect the power supply.

After completing the power-on checks above, print the information pages from the Mopier's Information Menu.

- Verify that the copy connect EIO appears on the Mopier configuration page.
- Verify that the HP Digital Copy 320 page prints.

Step 2 Display and Communication

Does the copy module LCD display indicate `READY TO COPY`? (YES = Go to Step 3: Error Messages and Problems)

Table 7-42. Display and Communication Checks

Problem	Recommended Action
The Fan works, but the display is blank with no backlight.	<ul style="list-style-type: none"> ● Re-check power availability. ● Check the front panel connections and cable. ● Reseat the ribbon cable into the connector on the front panel. ● Suspect the front panel or the cable.
The display is blank with the backlight on.	<ul style="list-style-type: none"> ● Check the front panel connections and cable. ● Inspect and reseat the ribbon cable into the connector on the front panel. ● Check the connections to and reseat the Power Supply and Main Board Assemblies. ● Reseat the copy connect EIO card and copy processor card. ● Check the connections between the copy connect EIO card and the Copy Processor card. ● Perform an offline test (page 667) to confirm the control PCA is good. ● Perform a Copy Processor LED test (page 664). If the Copy Processor is okay, suspect the front panel. Replace the suspected part.
The front panel backlight comes on and display shows the logo, a boot icon, or error message.	<ul style="list-style-type: none"> ● Perform a Copy Processor LED test (page 664) to confirm that the Copy Processor is okay. If necessary, replace the Copy Processor. ● Reseat the copy connect EIO card and the copy processor card. ● Check the connections between the copy connect EIO card and the Copy Processor card. ● Print a directory of the Mopier's hard disk drive to check that the Copy Module Firmware is installed (see page 592). ● Make sure <code>Loading Program 1</code> displays on the Mopier's control panel during bootup. If it does not, re-download the copy module firmware (see page 107). ● If the display shows an error message, see page 654 to resolve the problem. ● If the display stops at one of the four boot icons, note which and see page 666 to resolve the problem.

Step 3 Error Messages and Problems

Have you resolved error messages? (YES = Go to Step 5: Paper Path)

Note

Show or print the event log for the copy module or Mopier from the Mopier's Information Menu.

- Does the **copy module's front panel** report any errors? (See page 654 and take appropriate actions.)
- Does the **Mopier's control panel** report any copy module errors? (See page 544 and take appropriate actions.)
- Does the **Mopier's event log** report any errors? (See page 538 and take appropriate actions.)

Status Messages

This section shows status messages that display on the HP Digital Copy 320 Front Panel when there is a problem with the HP Digital Copy 320. There are 3 different types of errors made by the HP Digital Copy 320:

- Boot Errors (page 655)
- Equipment Errors (page 655)
- Temporary Errors (page 658)

For Mopier problem solving information, see the Mopier troubleshooting flowchart starting on page 518. For Mopier and paper-handling devices error messages see page 542.

Boot Errors

Table 7-43. Boot Errors

Boot Error	Description
0x00058001	<p>Bad connection (displayed after the second icon is displayed)</p> <p>This error indicates a bad physical connection between the copy module and the printer. This could also indicate that the Scanner Service Agent failed to load, or that the printer ID is not an HP Mopier 320</p>
0x00058002	<p>No file (displayed after the third icon is displayed)</p> <p>This error indicates that a connection was established, the Scanner Service Agent loaded, but firmware was not found on the disk.</p>
0x00058003	<p>Bad file (displayed after the third icon is displayed)</p> <p>This error indicates that a connection was established, the Scanner Service Agent loaded, firmware was found on the disk, but one or more of the files appear to be corrupt. Note that the “bad file” error below can also indicate that the copy processor gave up on downloading the runtime firmware after trying several times. It can also occur sporadically if you try to print a printer configuration page while the copy processor is downloading the firmware</p>

Note

All other numbered Boot Errors (0x00000000-0x000007FF) indicate that the Copy Processor card failed its own diagnostics and is probably bad. These errors will likely be seen in conjunction with and can be confirmed by a blinking red LED on the Copy Processor LED test.

Equipment Errors

To correct an equipment error, turn the Mopier and HP Digital Copy 320 off and then turn both devices on. If the error message persists, replace the indicated part.

Table 7-44. Equipment Errors

Error Message	Description
DEVICE ERROR: EEPROM FAILURE	Turn the Mopier off and then on. If the error persists, replace the Control PCA and the EEPROM.
DEVICE ERROR: BACKSIDE RAM BUFFER FAILURE	An error occurred while accessing the backside RAM buffer. Replace the Control PCA.
DEVICE ERROR: MOTOR FUSE FAILURE	The motor has a blown fuse. <ul style="list-style-type: none">● Check connections to motors.● Check to see if the motors turn.● Replace the motor.● If the problem persists, replace the Control PCA.● If the problem persists, replace the Power Supply.
DEVICE ERROR: LAMP FUSE FAILURE	A Lamp has a blown fuse. <ul style="list-style-type: none">● Check connections to Lamps.● Replace the Control PCA.
DEVICE ERROR: BACKSIDE OPTICAL FAILURE	A problem occurred with the backside optical system. <ul style="list-style-type: none">● Check to see if the Lamp(s) turn on during an offline test. If yes, then clean the glass and optics. If no, replace the Lamp.● Check the Optical Unit cable connection.● Replace the Lamp.● If the problem persists, replace the Control PCA.
DEVICE ERROR: FRONTSIDE OPTICAL FAILURE	A problem occurred with the frontside optical system. <ul style="list-style-type: none">● Check to see if the Lamp(s) turn on during an offline test. If yes, then clean the glass and optics. If no, replace the Lamp.● Check the Optical Unit/Carrier Unit cable connection.● If necessary, replace the Lamp.● If the problem persists, replace the Control PCA.

Table 7-44. Equipment Errors (continued)

Error Message	Description
DEVICE ERROR: MECHANICAL FAILURE	<p>A mechanical problem occurred.</p> <ul style="list-style-type: none">● Check that the shipping lock has been removed and reinserted properly.● Check that the Home Position Sensor is connected.● Check the Carrier Belt.● Check the Flatbed Motor.● If the problem persists, replace the Flatbed Motor Unit.● If the problem persists, replace the Control PCA.● If the problem persists, replace the Power Supply.

Temporary Errors

A Temporary Error displays when problems with the paper path occur. The Front Panel will display the specific error and graphically illustrate the actions needed to correct the error.

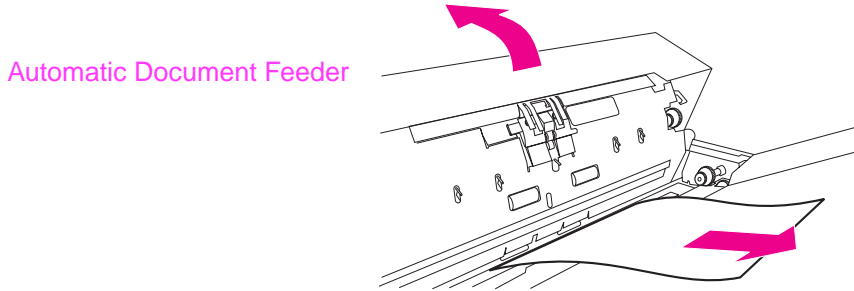

Table 7-45. Temporary Errors

Error Message	Description
ADF PAPER JAM	<p>Paper was not found on the ADF path before a READ command was executed, or paper did not pass through the ADF within the specified time. This error state can be reset by one of the following operations:</p> <ul style="list-style-type: none">● the copy module receives a CLEAR command● or remove paper from the ADF and close the ADF cover● visually inspect for bad alignment● If the problem is chronic, clean or replace the ADF pick rollers and separation pad
ADF COVER IS OPEN	<p>The ADF cover was opened during the ADF READ operation or the ADF cover was open when the ADF read started.</p>
ADF MISFEED	<p>A START command was received but a misfeed occurred from the ADF input tray. Restack the pages in the ADF input tray. Press START to continue the copy job.</p> <ul style="list-style-type: none">● visually inspect for bad alignment● If the problem is chronic, clean or replace the ADF pick rollers and separation pad

Step 4 Information Pages

Print information pages from the Mopier's Information Menu. See page 587.

Step 5 Paper Path

Is the ADF feeding paper correctly? (YES = Go to Step 6: Image Quality)

- Does the copy module cause damage to the original, experiencing frequent mispicks, double-feeds, jams, or skewed paper feeding?
- Check paper types used by customer and suggest to use the flatbed if out of specification.
- Determine if the ADF cleaning interval has been exceeded. (Check the configuration page. See “Sample Copy Module Configuration Page” on page 591 for an example. Inspect and clean the ADF assemblies as needed.)
- Determine if the maintenance interval has been exceeded. (Check the configuration page. See “Sample Copy Module Configuration Page” on page 591 for an example. Inspect and replace the Pick Rollers and Separation Pad as needed.)
- Try a copy from the flatbed to isolate the problem to the ADF mechanism or optics.
- Confirm connection to the ADF (3 cables), confirm ADF Motor Belt, and perform a test of the ADF sensors in the copy module service mode to ensure each sensor moves freely.
- Perform an ADF offset calibration (page 126).
- Perform the ADF test in service mode or an offline test and inspect mechanisms for failure. Be sure to use paper that conforms to HP recommended paper specifications for this test. Replace implicated components.
- See “Error Conditions” on page 661.

Step 6 Image Quality

Is the image quality acceptable? (YES = End)

- Does the copy module output display problems with any of the following? Resolution, grayscale, jitter, skew, image placement, improper image scaling, image out of position, part of image missing, unclear image.
- Determine if the problem is isolated to the flatbed, ADF, or occurs from both. Check to see if the suggested cleaning interval has been exceeded and clean if necessary. (See error and symptom tables and take recommended action.)

Table 7-46. Error Conditions

Error Condition/Symptom	Remedies
Power Lamp does not light	<ul style="list-style-type: none"> ● Check the power plug and the Front Panel connection. ● Make sure that the PCA tray is inserted. ● If the problem persists, replace the Control PCA. ● If the problem persists, replace the Power Supply.
No image or image scrambled	<ul style="list-style-type: none"> ● Check interface connections. ● If the problem persists, replace the Control PCA. ● Check the backside or frontside (if frontside only, replace the Carrier Unit).
Grayscale or resolution is bad on the flatbed	<ul style="list-style-type: none"> ● Check that the document is placed on the flatbed correctly. ● Clean both sides of the flatbed glass. ● Clean the Carrier Unit. ● If the problem persists, replace the Carrier Unit. ● If the problem persists, replace the Control PCA.
Excessive Jitter on the flatbed	<ul style="list-style-type: none"> ● Check to see if the cables routed in the mechanism frame are in contact with the Carrier Frame. Reroute the cables if necessary. ● Check for objects blocking the movement of the Carrier Unit during scan. Clean or remove. ● Check if carrier unit belt is loose. ● Replace FB Motor Unit if necessary. ● Clean and relubricate the Carrier Unit Shaft. ● Lubricate the carrier guide rail. ● Replace the Control PCA if necessary.

Table 7-46. Error Conditions (continued)

Error Condition/Symptom	Remedies
Image is out of position or partly missing from the flatbed	<ul style="list-style-type: none"> ● Run an offset adjustment. ● Make sure that the glass plate assembly has been reseated correctly if moved. ● Replace the Carrier Unit.
Image is unclear or faded from the flatbed	<ul style="list-style-type: none"> ● Check that the document is placed on the flatbed correctly. ● Inspect and clean both sides of the flatbed glass. ● Clean the Carrier Unit. ● If the problem persists, replace the Carrier Unit. ● If the problem persists, replace the Control PCA.
Magnification is incorrect from the flatbed	<ul style="list-style-type: none"> ● Check to see if magnification is incorrect on subscan or mainscan direction. ● Subscan: check the Carrier Belt and tighten the adjustment screw, and lubricate the Carrier Shaft and Guide Rail. If the problem persists, replace the Flatbed Motor. ● Mainscan: replace the Carrier Unit. If the problem persists, replace the Control PCA.
Grayscale or resolution is bad on the ADF	<ul style="list-style-type: none"> ● Check to see that the document is placed in the ADF paper chute correctly. ● Check to see that the document size is supported by the ADF. ● Frontside: clean both sides of the glass and clean the Carrier Unit. If the problem persists, replace the Carrier Unit. If the problem persists, replace the Control PCA. ● Backside: clean the glass under the ADF and clean the Optical Unit. If the problem persists, replace the Optical Unit. If the problem persists, replace the Control PCA.
Excessive Jitter on the ADF	<ul style="list-style-type: none"> ● Check for contaminants on the Feed Roller, Eject Roller, and Idler Feed Roller. ● Check that the document size is supported by the ADF. ● Check the ADF for objects blocking mechanical operation. ● Clean the ADF. ● If the problem persists, replace the ADF.

Table 7-46. Error Conditions (continued)

Error Condition/Symptom	Remedies
Image is out of position or partly missing from the ADF	<ul style="list-style-type: none"> ● Check that the original document size is supported by the ADF. If not, use the flatbed. ● Perform an offset adjustment. ● Clean the ADF. ● If the problem persists, replace the ADF. ● If frontside, replace the Carrier Unit. ● If backside, replace the Optical Unit.
Image is unclear, faded, or streaked from the ADF	<ul style="list-style-type: none"> ● Inspect and clean both sides of the flatbed glass. ● Clean the ADF. ● Frontside: clean the Carrier Unit. If the problem persists, replace the Carrier Unit. If the problem persists, replace the Control PCA. ● Backside: clean the Optical Unit and back Lamp. If the problem persists, replace the Optical Unit. If the problem persists, replace the Control PCA.
Magnification is incorrect on the ADF	<ul style="list-style-type: none"> ● Check that the original document paper type is supported by the ADF. If not, then use the flatbed. ● Check to see if magnification is incorrect on the subscan or mainscan direction. ● Subscan: inspect the Feed Roller, Eject Roller and Idler Feed Roller for foreign objects and clean if necessary. Clean the ADF. If the problem persists, replace the Control PCA. ● Mainscan frontside: replace the Carrier Unit. If the problem persists, replace the Control PCA. ● Mainscan backside: replace the Optical Unit. If the problem persists, replace the Control PCA.
Frequent paper feed errors: jams, mispicks, double-feeds, damaged originals, skewed copies on the ADF	<ul style="list-style-type: none"> ● Check that the original document paper type is supported by the ADF. If not, then use the flatbed. ● Make sure that the originals are being loaded into the ADF correctly. ● Inspect the Pick Rollers and Separation Pad for contamination and clean. ● Clean the ADF. ● Replace the Pick Rollers and Separation Pad. ● Perform an offset calibration.
Front panel buttons and touch screen are not working	<ul style="list-style-type: none"> ● Perform Front Panel tests. ● Replace the Front Panel. ● If the problem persists, replace the Control PCA.

Testing the HP Digital Copy 320

Use the following tests to diagnose problems with the copy module.

- Print information pages (page 587)
- Copy Processor LED Test (below)
- Copy Module Boot Up Icon Conditions (page 666)
- Copy Module Offline Test (page 667)
- Other Tests (page 669)
- Service Mode Tests (page 671)

Note

If the 1394 connect or firmware download fails, the display will freeze at icon 2, 3, or 4. The display of any icon is the best indication that the Front Panel is functioning correctly.

Copy Processor LED Test

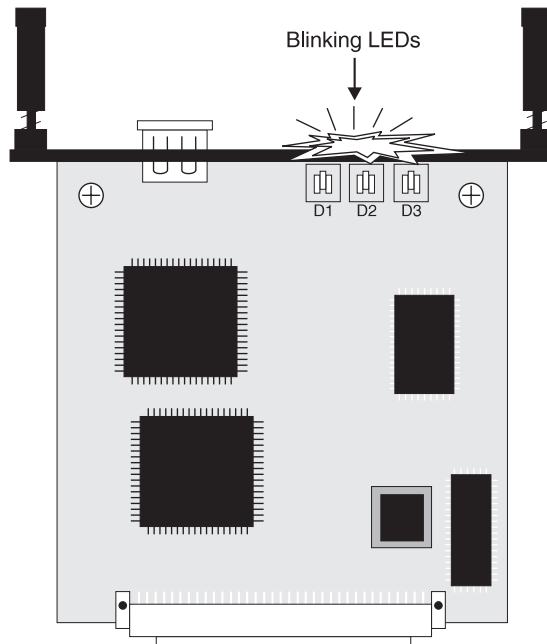

Figure 7-36 Copy Processor LEDs

Performing a Copy Processor LED Test

- 1 From the back of the copy module, unscrew the left thumb screw on the Copy Processor Card.
- 2 Gently pull the loosened thumbscrew downward, moving the bulkhead of the Copy Processor Card slightly away from the body of the copy module. Be careful not to unseat the Copy Processor Board.
- 3 Look down inside the copy module near the bulkhead of the Copy Processor Card. You should be able to see the Copy Processor LEDs.

Note

If you cannot see the LEDs you may have to temporarily remove the Copy Processor bulkhead. To do this, remove 2 screws to temporarily detach the bulkhead from the PCA so that the LEDs may now be seen easily. Reinstall the Copy Processor.

Copy Processor LED Test Results

Table 7-47. Copy Processor LED Test Results

If LED is	Indicates that Copy Process or is
Blinking green	Good - do not replace it
Blinking red	Bad and should be replaced
Blinking red and green	Probably good, but firmware download was not successful (Check the "Copy Module Boot Up Icon Conditions" on page 666 and the printer connections)

Copy Module Boot Up Icon Conditions

Table 7-48. Icon Conditions

Icon Condition	Recommended Action
No icon	<ul style="list-style-type: none"> ● If the display is blank, or only the backlight appears, or it freezes at the logo, see “Display and Communication” on page 653. ● Check connections and suspect the Front Panel. (If the Copy Processor passes the LED test, the Front Panel should not stop at Icon 1.)
Stops at Icon 1	<p>The copy processor did not pass its power on tests.</p> <ul style="list-style-type: none"> ● Perform a Copy Processor LED test and if the test indicates the Copy Processor is bad, replace it.
Stops at Icon 2	<p>The Copy Processor likely cannot make the connection to the printer.</p> <ul style="list-style-type: none"> ● Check connections. ● Reseat cards. ● Check the printer's configuration pages for the Copy Connect EIO and Digital Copy 320 Pages. ● Ensure the Mopier and its peripherals are working correctly. ● Make sure Loading Program 1 displays on the Mopier's control panel during bootup. If it does not, re-download the copy module firmware (see page 107). ● Make sure the Mopier is an HP Mopier 320.
Stops at Icon 3	<p>Copy module firmware failed to download.</p> <ul style="list-style-type: none"> ● Check connections. ● Reseat cards. ● Print a directory of the Mopier's hard disk drive to check that the Copy Module Firmware is installed (see page 592). ● Redownload the Copy Module Firmware (page 108). ● Make sure the Mopier is an HP Mopier 320.
Stops at Icon 4	<p>The system could not start the downloaded copy module firmware.</p> <ul style="list-style-type: none"> ● Perform the recommended actions above. ● Make sure Loading Program 1 displays on the Mopier's control panel during bootup. If it does not, re-download the copy module firmware (see page 107). ● Print a directory of the Mopier's hard disk drive to check that the Copy Module Firmware is installed (see page 592). ● Redownload the Copy Module Firmware (page 108). ● Check the printer's configuration pages for the Copy Connect EIO and Digital Copy 320 Pages.

Note

Download is complete and successful when the main menu replaces Icon 4.

Copy Module Offline Test

This test does not depend on a functioning Copy Processor or a functioning Front Panel. This is a pass or fail test. If the Carrier Unit moves, the ADF feeds paper, and the Lamps come on, then the test is passed. If this does not happen, the copy module will appear to be dead.

Successful completion of this test will exercise the functionality of both Lamps, the Carrier Unit, the Optical Unit, and the Control PCA.

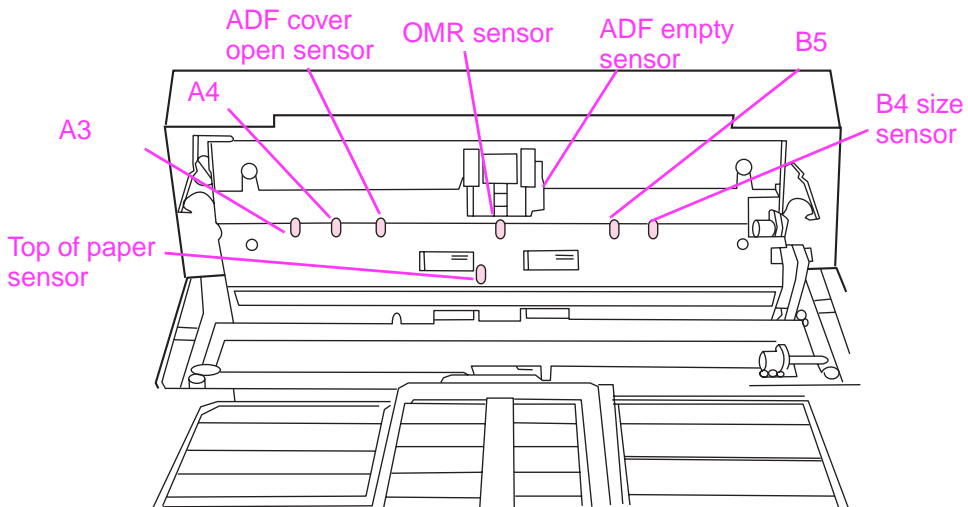

Figure 7-37 Locations of ADF Sensors

- 1 Turn the copy module off.
- 2 Open the ADF cover and pull the ADF Empty Sensor to the paper out position, and push the B5 Paper Sensor (with respect to portrait paper) while turning the copy module on. When you hear the copy module begin to initialize, release the sensors.
- 3 Close the ADF and then open the ADF.

- 4 Close the ADF. At this point you should be in the offline test mode. If no paper is loaded within 5 seconds, the flatbed test executes. (The Carrier Unit moves and the Lamp lights as if they were making a flatbed copy.)
- 5 Open the ADF to stop the flatbed test.
- 6 Have a stack of paper ready. Close the ADF and load paper.
- 7 The ADF will move paper and the Lamps will light as if making a two-sided copy.

Note

Successful completion of this test will exercise the functionality of both Lamps, the Carrier Unit, the Optical Unit, and the Control PCA.

Other Tests

Use the tests listed below to determine if a part is “good” or “bad” without swapping parts.

Table 7-49. Other Tests

Possible Bad Part	Tests and indicators that the part is “Good” or “Bad”
Copy Processor Board	Good if: <ul style="list-style-type: none">● the Front Panel icons display.● the Copy Processor LED test (page 664) shows green or green and red.
Control PCA	Good if: <ul style="list-style-type: none">● there are no equipment errors.● the fan is on.● the Front Panel works.● the offline test is OK.
Front Panel	Good if: <ul style="list-style-type: none">● the backlight comes on (might be OK).● logo displays (probably OK).● the first icons display (definitely OK).● passes the service mode tests (which catch small defects such as bad pixels, stuck buttons, or no touch).
Power Supply	Good if: <ul style="list-style-type: none">● the fan comes on.● the start button LED lights.● the Front Panel displays an image.
Paper handling mechanisms	Good if: <ul style="list-style-type: none">● the service mode ADF test works.● the offline test works.● both tests work without damaging the original.

Table 7-49. Other Tests (continued)

Possible Bad Part	Tests and indicators that the part is “Good” or “Bad”
Optics	Good if: <ul style="list-style-type: none">● there is no optical failure. (An optical failure may also indicate it is time to clean the optics.)● Lamps light during the offline test.● a simple page is copied.
Copy Module Firmware	Good if: <ul style="list-style-type: none">● the disk directory matches the standard (file names and sizes).● Loading Program 1 is visible on the Front Panel of the Mopier.● the Mopier configuration page identifies an HP Mopier 320.● copy module firmware is reloaded.
Copy Connect EIO	Good if: <ul style="list-style-type: none">● shows up on the configuration pages.● the fourth startup icon is passed.
ADF Sensors	Good if: <ul style="list-style-type: none">● the service mode test of each sensor passes.
ADF Lamp	Good if: <ul style="list-style-type: none">● resistor R3 is temporarily shorted to ground and the lamp lights.● lights during an offline test.
Home Position Sensor	Bad if: <ul style="list-style-type: none">● the Carrier Unit bumps into the side of the copy module for 5 seconds.
Carrier Unit Lamp	Good if: <ul style="list-style-type: none">● lights during an offline test.

Service Mode Tests

The following tests are available through the copy module's Tests Menu in service mode. Follow the prompts on the front panel to complete the tests.

1 Front panel tests

- display
- touch screen

2 Keypad/LED tests

- keypad buttons
- start button LED

3 Sensors Tests (ADF)

4 ADF paper feed tests

8

Parts and Diagrams

Chapter contents

How to Use the Part Lists and Diagrams - - - - -	674
Illustrations and Parts Lists - - - - -	675
Mopier and Paper-handling Components - - - - -	676
Printer Parts and Diagrams- - - - -	680
Paper-Handling Devices Parts and Diagrams - - - - -	694
Alphabetical Parts List (Mopier and Paper Handling Devices)	714
Numerical Parts List (Mopier and Paper Handling Devices)	724
HP Digital Copy 320 Parts and Diagrams - - - - -	735
Alphabetical Parts List (Copy Module) - - - - -	750
Numerical Parts List (Copy Module) - - - - -	754

How to Use the Part Lists and Diagrams

The figures in this chapter illustrate the major subassemblies and their component parts. Each table lists the reference designator (item number) for each part, the associated part number for the item, the quantity, and a description of the part.

While looking for a part number, pay careful attention to the voltage listed in the description column to ensure that the part number selected is for the correct model of printer.

Note

Parts that have no item or part number listed are not field-replaceable parts and cannot be ordered.

Ordering Parts

All standard part numbers listed are stocked and may be ordered from HP's PSD/SMO or PSD/SME.

Hewlett-Packard Co. Product Support Division/Support Materials Organization 8050 Foothills Blvd. Roseville, CA 95678 Parts Direct Ordering 1-800-227-8164 (U.S. Only)

Hewlett-Packard Co. Product Support Division/Support Materials, Europe Wolf-Hirth Strasse 33 D-7030 Böblingen, Germany (49 7031) 14-2253
--

Contact your local HP Parts Coordinator for other local phone numbers.

Common Hardware

See table 6-1 in Chapter 6 for a list of the common hardware used in the printer.

Illustrations and Parts Lists

The following illustrations and their associated parts tables list the field-replaceable components for this printer. Where applicable, the exchange part number is listed immediately following the original equipment part numbers. This chapter also provides two cross-reference tables of all the parts listed in this chapter: Table on page 714 lists the parts in alphabetical order, and Table 8-18 on page 714 lists the parts in numerical order. Both tables are cross-referenced to the appropriate figure and reference designator in this chapter.

Mopier and Paper-handling Components

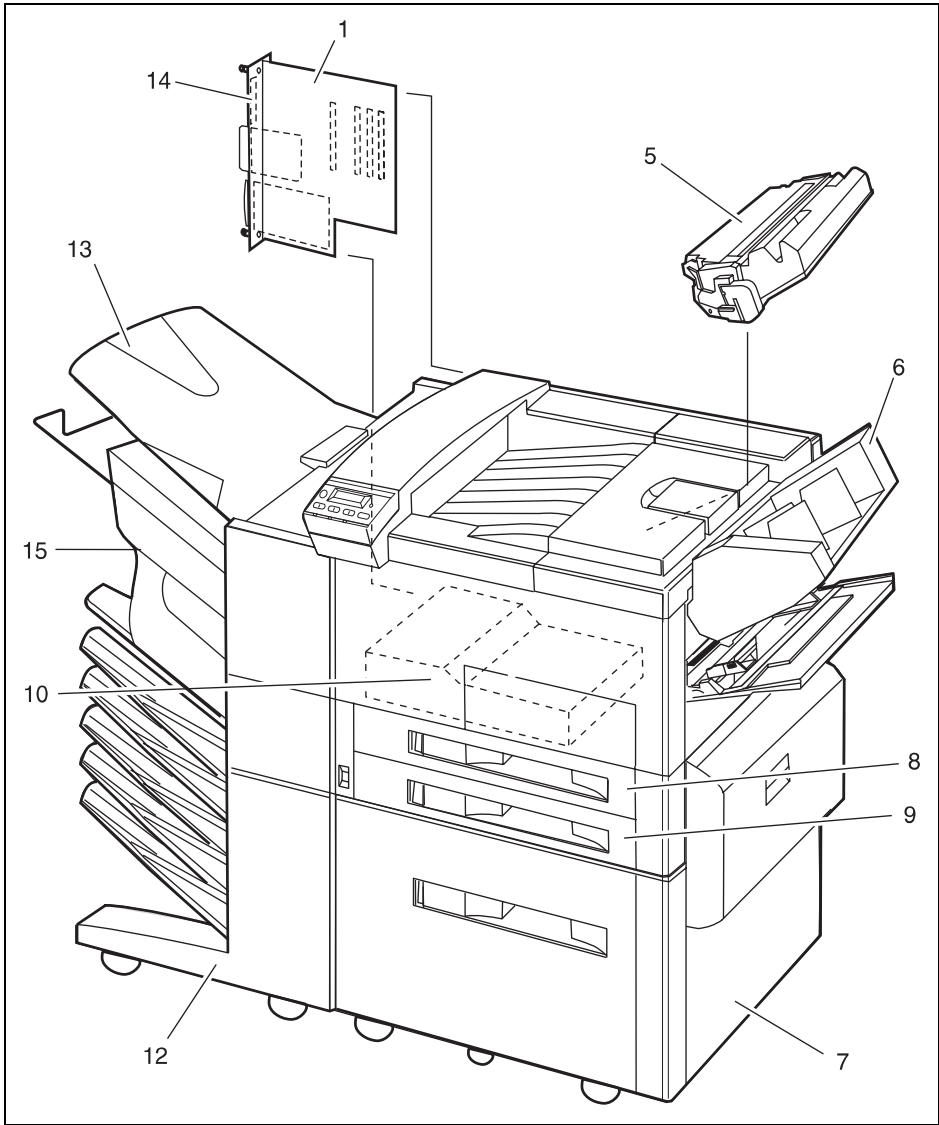

Figure 8-1 HP Mopier 320 Paper-Handling Components

Table 8-1. Printer and Paper-Handling Components

Ref	Description/Product Number	Part/Exchange Number	QTY
01	Formatter Assembly	C4107-67901	
01A	Formatter Assembly, Exchange	C4107-69001 (ex.)	
05	Toner Cartridge/C4182X		
06	Envelope Feeder/C4242A	C3765-60501	1
07	2000-sheet Input Tray (Tray 4)/C4237A	R95-3002-000CN	1
not shown	2 x 500-sheet Input Tray (Tray 4 and 5)/C4236A	R95-3003-000CN	
08	Tray 2	RG5-3951-000CN	1
09	Tray 3	RG5-3952-000CN	1
not shown	Paper Size Guide (Trays 2 and 3)	RF5-1484-000CN	1
not shown	Paper Size Guide Label (Trays 2 and 3)	RS5-8605-000CN	1
10	Duplexer/C4782A	C4782-60501 C4782-69501 (ex.)	1
12	8-bin Mailbox/C4240B		1
12	5-bin Mailbox with Stapler/C4241A		1
12	5-bin Mailbox for Stapler/C4241A (5-bin Mailbox only, without the Stapler Unit.)	C4787-60502 C4787-69502 (ex.)	1
13	Face-up Bin	RB1-6491-000CN	1
14	EIO Coverplate	5182-5899	3
15	Stapler Assembly	C4787-60500	1
not shown	7-bin Tabletop Mailbox/C4238A	R95-3007-000CN	1
not shown	Stand for 7-bin Tabletop Mailbox/C4239A	C4784-60500	1
not shown	Packaging Kit, printer	5041-9238	
not shown	Packaging Kit, duplexer	C3762-60500	
not shown	Packaging Kit, 2000-sheet Input Tray	C3763-60500	
not shown	Packaging Kit, 8-bin Mailbox	C3764-60500	
not shown	Packaging Kit, Envelope Feeder	C3765-60500	
not shown	Maintenance Kit, 100-120V/C3914A	C3914-69001 (ex.)	
not shown	Maintenance Kit, 220-240V/C3915A	C3915-69001 (ex.)	
not shown	C-link Cable Assembly 61 cm (Engine to 2000-sheet Input Tray)	C3763-60502	
not shown	C-link Cable Assembly 97 cm (8-bin Mailbox to Stapler)	C3766-60539	
not shown	Stapler Cartridges (3-pack)/C3772A		

Table 8-1. Printer and Paper-Handling Components (continued)

Ref	Description/Product Number	Part/Exchange Number	QTY
not shown	Power Box (includes bracket clip)	C4781-60500	
not shown	Jumper Cable, Short	C4781-60501	
not shown	Jumper Cable, Long	C4781-60502	

Printer Parts and Diagrams

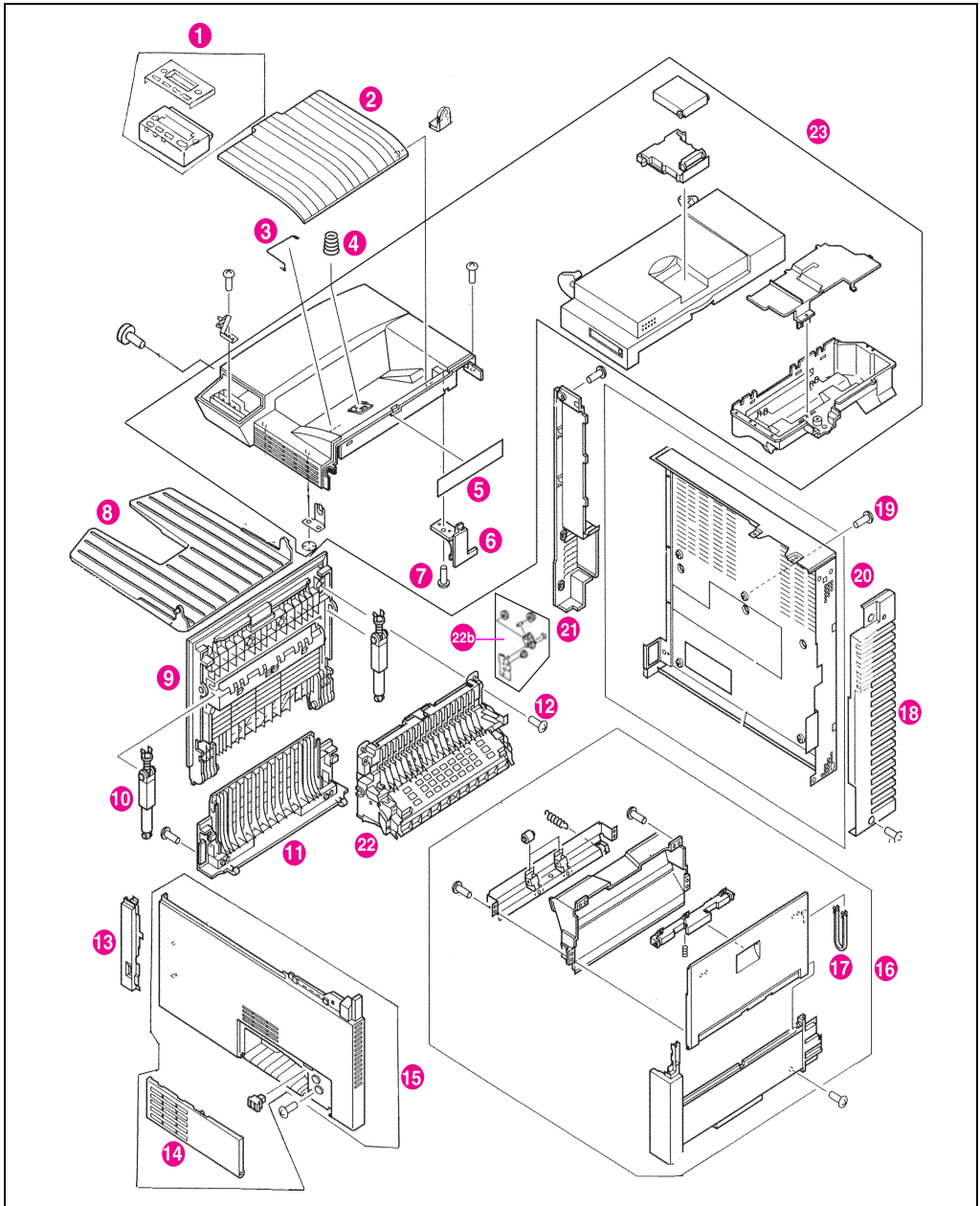

Figure 8-2 Printer Covers and Doors

Table 8-2. Printer Covers and Doors

Ref	Description	Part Number	QTY
1	Display, Control Panel	RG5-4384-000CN	1
1a	Overlay, Control Panel (English)	C4214-40029	1
1a	Overlay, Control Panel (French)	C4214-40030	1
1a	Overlay, Control Panel (Italian)	C4214-40031	1
1a	Overlay, Control Panel (Portuguese)	C4214-40032	1
1a	Overlay, Control Panel (German)	C4214-40041	1
1a	Overlay, Control Panel (Spanish)	C4214-40042	1
2	Tray, Output-Face-down	RB1-6490-000CN	1
3	Spring, Torsion	RB1-6509-000CN	1
4	Spring, Compression	RB1-6493-000CN	1
5	Label, Operation	RS5-8676-000CN	1
6	Hinge Plate	RB2-3641-000CN	1
7	Screw, M4 x 10	XA9-0870-000CN	
8	Tray, Face-up	RB1-6491-000CN	1
9	Delivery Cover (Left Side F/U)	RB2-3558-000CN	1
10	Hinge, Stopper	RF5-2701-000CN	2
11	Cover, Left-Lower	RB1-6480-000CN	1
12	Screw, M4 x 8	XA9-0605-000CN	
13	Cover, Switch	RB1-6492-000CN	1
14	Front Cover (Duplex Jam Removal)	RB2-3626-000CN	1
15	Front Cover	RG5-4362-000CN	1
16	Right Cover Assembly	RG5-1915-000CN	1
17	Open/Close Stopper	RB1-6484-000CN	1
18	Right, Lower Cover (Rear Plastic on Sheet Metal)	RB2-3642-000CN	1
19	Screw, M3 x 8	XA9-0872-000CN	
20	Cover, Rear	RF5-1402-000CN	1
21	Electrical Cover (Rear by Formatter)	RB1-6489-000CN	1
22	Diverter Assembly	RG5-4325-000CN	1
22a (not shown)	Gear, 20T	RS5-1127-000CN	1
22b	Diverter Drive Assembly	RF9-1249-000CN	1
23	Top Cover Assembly	RG5-4360-000CN	1

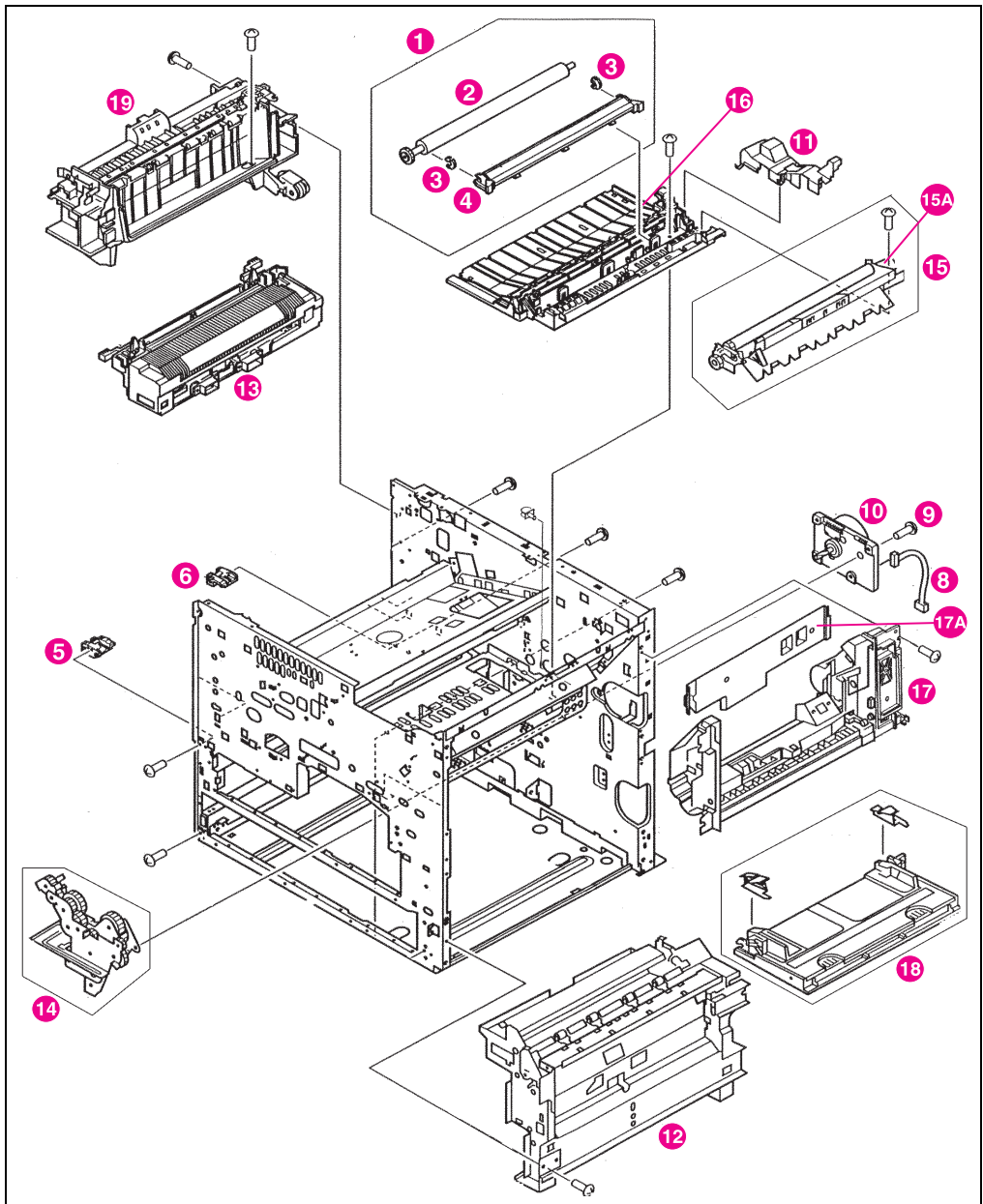

Figure 8-3 Printer Internal Components (1 of 4)

Table 8-3. Printer Internal Components (1 of 4)

Ref	Description	Part Number	QTY
1	Assembly, Transfer Roller	RG5-4304-000CN	1
2	Roller, Transfer	RF5-2675-000CN	1
3	Transfer Guide Bushing	RB1-6441-000CN	2
4	Transfer Guide	RF5-2676-000CN	2
5	Holder, Damper-Front	RB1-6461-000CN	1
6	Holder, Damper-Rear	RB1-6462-000CN	1
8	Main Motor Cable	RG5-4386-000CN	1
9	Screw, M4 x 8 TP	XB6-7400-807CN	1
10	Main Motor	RH7-5219-000CN	1
11	Clutch Cover	RB2-3631-000CN	1
12	Paper Input Unit (PIU) (See Figure 8-7 on page 690 to order)	RG5-4434-000CN	1
12	Paper Input Unit (PIU) (ex.)	C4214-69004	1
13	Fusing Assembly, 110V	RG5-4315-000CN	1
x	Fuser Lock Lever-Right	RB1-6615-020CN	1
x	Fuser Lock Lever-Left	RB1-6616-020CN	1
13	Fusing Assembly, 110V (ex.)	C4214-69007	1
13	Fusing Assembly, 220V	RG5-4317-000CN	1
13	Fusing Assembly, 220V (ex.)	C4214-69008	1
14	Printer Drive Assembly	RG5-4365-000CN	1
15	Registration Assembly	RG5-4303-000CN	1
15A	Electromagnetic Clutch	RH7-5187-000CN	1
16	Feeder Assembly (see figure 8-7 on page 690 for detail)	RG5-4305-000CN	1
17	Tray 1 Assembly (see figure 8-7 on page 690 for detail)	RG5-4330-000CN	1
17A	Cover, Internal Tray	RB1-6749-000CN	1
18	Tray 1 Assembly Cover	RG5-4329-000CN	1
19	Face-down Delivery Assembly (see figure 8-7 on page 690 for detail)	RG5-1874-000CN	1

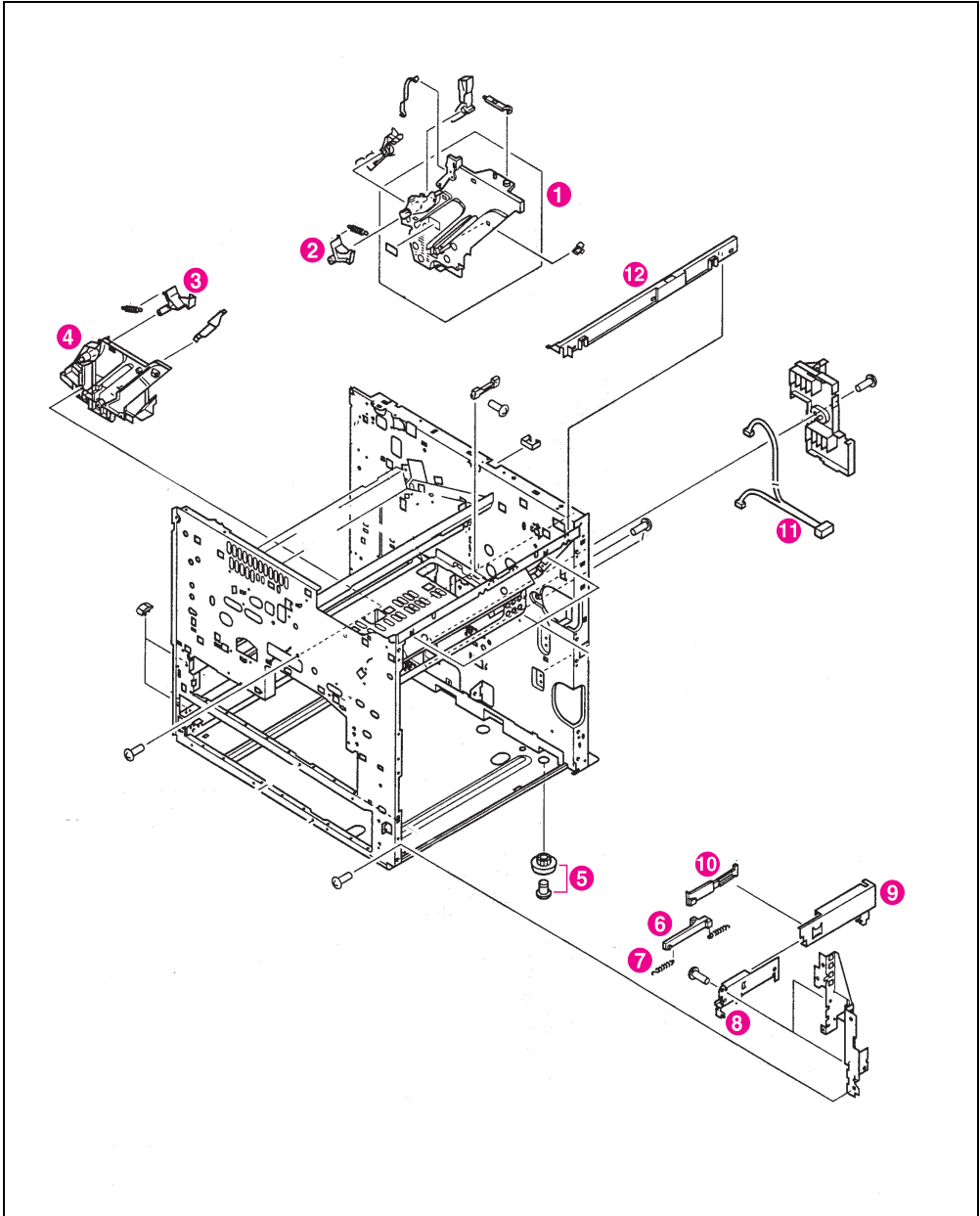

Figure 8-4 Printer Internal Components (2 of 4)

Table 8-4. Printer Internal Components (2 of 4)

Ref	Description	Part Number	QTY
1	Guide, Rear	RF5-2726-000CN	1
2	Release, Arm	RB1-6446-000CN	
3	Arm-Pressure-front	RB1-6444-000CN	
4	Guide, Front	RB2-3622-000CN	
5	Foot	RB1-6421-000CN	
6	ROD	RB1-6778-000CN	
7	Spring, Tension	RS5-2499-000CN	
8	Guide, Rail	RB1-6776-000CN	
9	Stopper, Rail	RB1-6777-000CN	
10	Stopper, Rail	RB1-6783-000CN	
11	Cable, Tray Sensor	RG5-1920-000CN	1
12	Cover, Upper Right	RB1-6464-000CN	

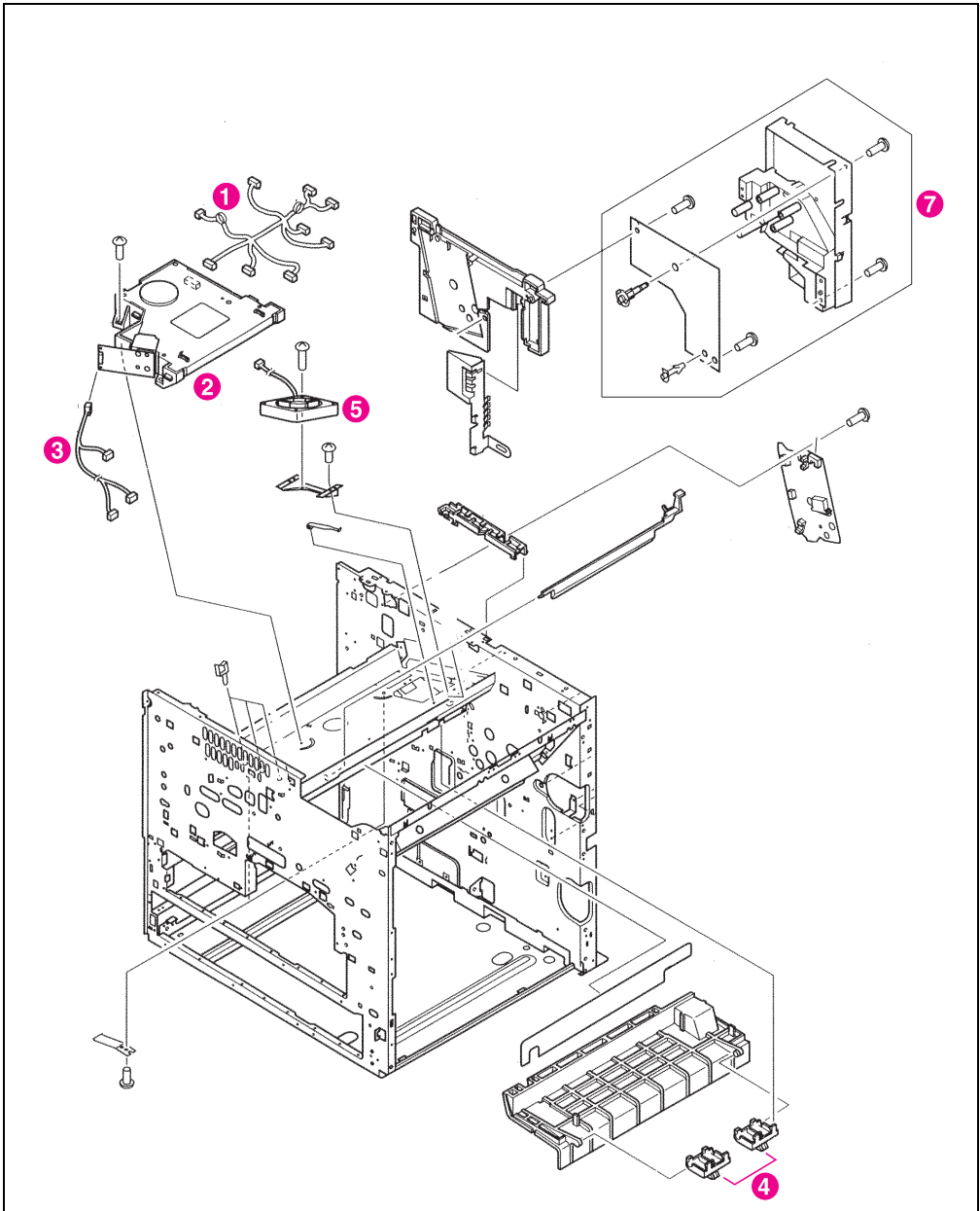

Figure 8-5 Printer Internal Components (3 of 4)

Table 8-5. Printer internal Components (3 of 4)

Ref	Description	Part Number	QTY
1	Cable, Scanner Motor	RG5-4378-000CN	1
2	Assembly, Laser Scanner	RG5-4344-000CN	1
2	Assembly, Laser Scanner (exchange)	C4214-69003 (ex.)	1
3	Laser and Control Panel Cable	RG5-4377-000CN	1
4	Stopper, CG	RB1-6427-000CN	2
5	Fan, FM2/Laser Scanner	RH7-1266-000CN	1
6	Shutter, White	RB1-6473-000CN	1
7	High-Voltage Power Supply	RG5-4306-000CN	1

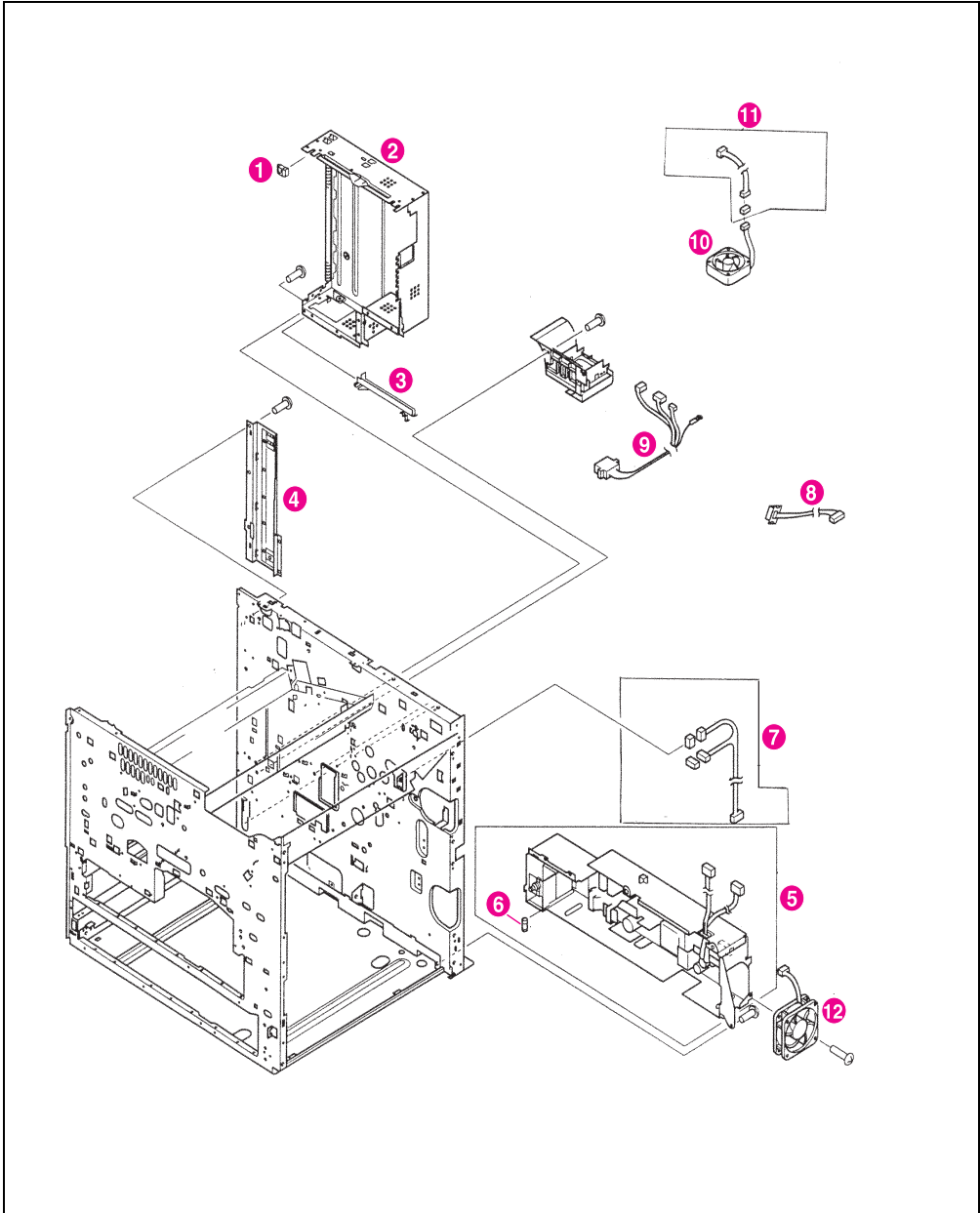
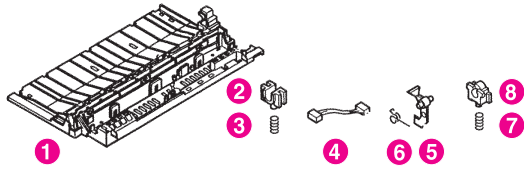

Figure 8-6 Printer Internal Components (4 of 4)

Table 8-6. Printer Internal Components (4 of 4)

Ref	Description	Part Number	QTY
1	Guides, Interface	RB1-6771-000CN	2
2	Shield, Formatter	RF5-2678-000CN	1
3	Guide, Slide	RB1-6775-000CN	1
4	Shield, Plate	RF5-1464-000CN	1
5	Power Supply, Low-Voltage 110 V	RG5-4300-000CN	1
5	Power Supply, Low Voltage-220 V	RG5-4301-000CN	1
7	Cable, Registration	RG5-1928-000CN	1
8	Cable, Fuser 2	RG5-1850-000CN	1
9	Cable, Fuser 1	RG5-4381-000CN	1
10	Fan, FM3/Formatter	RH7-1271-000CN	1
11	Cable, Fan 1	RG5-1921-000CN	1
12	Fan, FM1/Low Voltage Power Supply	RH7-1396-000CN	1

A



B

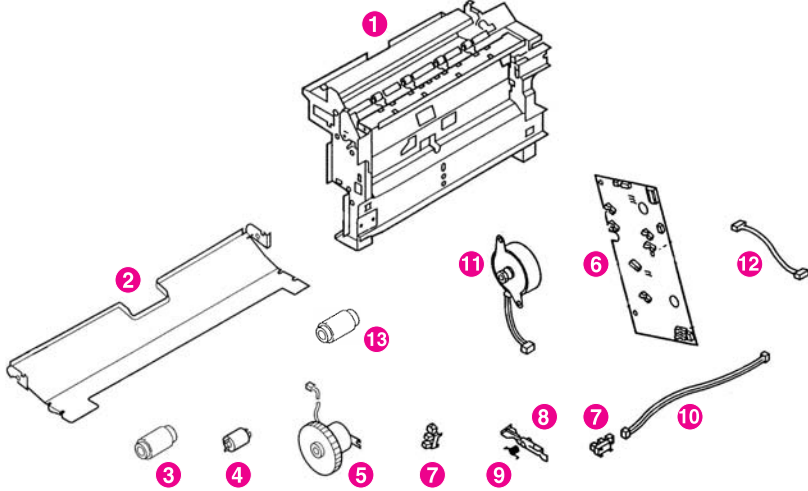

C

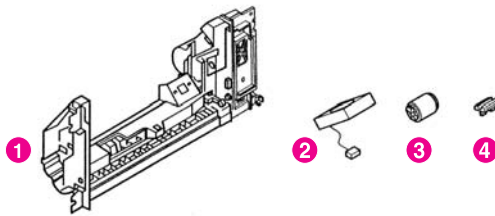

D

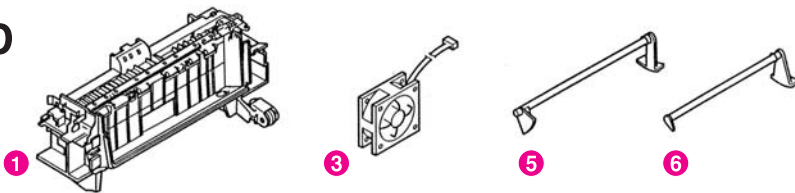

Figure 8-7 Detail of Assemblies

Table 8-7. Detail of Assemblies

Ref	Description	Part Number	QTY
A1	Feeder Assembly	RG5-4305-000CN	
A2	Block, Shaft Holding, Front	RB2-3503-000CN	1
A3	Compression Spring, Front	RS6-2072-000CN	1
A4	Sensor Cable	RG5-1843-000CN	1
A5	Sensor Arm PS1	RB1-6417-000CN	1
A6	Sensor Arm Spring	RB1-6409-000CN	1
A7	Compression Spring, Rear	RS6-2073-000CN	1
A8	Block, Shaft Holding, Rear	RB2-3504-000CN	1
B1	Assembly, Paper Pickup	RG5-4334-000CN	1
B2	Plate, Guide-Upper	RB1-6582-000CN	
B3	Roller, Pickup	RF5-2708-000CN	
B4	Limiter, torque	RB2-3581-000CN	2
B5	Clutch, Paper Feed	RH7-5188-000CN	1
B6	PCA, PIU	RG5-1860-000CN	1
B7	Photo Interrupter	WG8-0291-000CN	1
B8	Arm, Sensor-PS2	RB1-6557-000CN	1
B9	Spring, Sensor Arm	RB1-6558-000CN	1
B10	Cable, Sensor	RG5-1859-000CN	1
B11	Motor, PIU	RH7-1350-000CN	1
B12	Cable, Paper Pickup	RG5-1861-000CN	1
B13	Feed and Separation Rollers	RF5-1834-000CN	4
C1	Assembly, Tray 1	RG5-4330-000CN	1
C2	Fan, FM5	RH7-1397-000CN	
C3	Tray1 Feed Roller	RB1-9526-000CN	1
C4	Tray 1 Separation Pad	RF5-2703-000CN	1
D1	Delivery Assembly	RG5-1874-000CN	1
D3	Fan, FM4/Delivery Assembly	RH7-1289-000CN	1
D5	Paper Height Lever	RB1-6693-000CN	1
D6	Paper Sensing Lever	RB1-6692-000CN	1

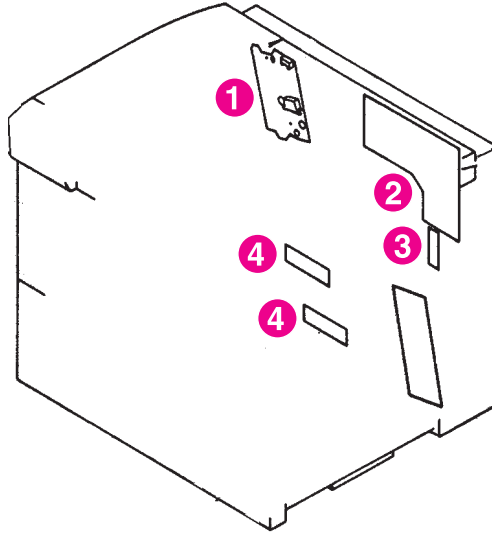
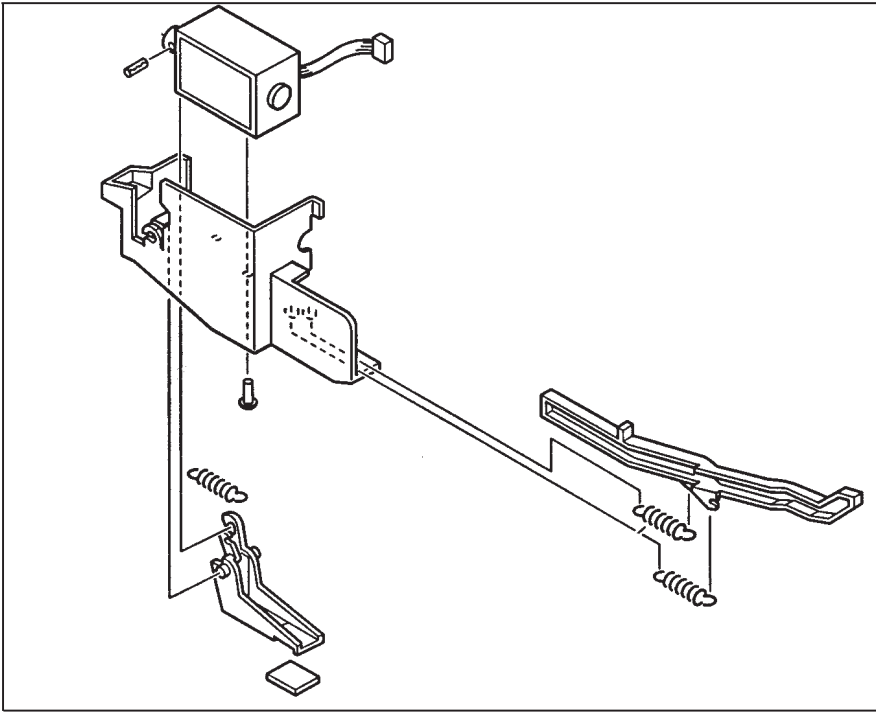

Figure 8-8 PCB Assembly Location Diagram

Table 8-8. PCB Assembly Locations

Ref	Description	Part Number	QTY
1	PCB, Switch/Sensor	RG5-1846-000CN	1
2	Assembly, DC Controller PCB	RG5-4375-000CN	1
2	Assembly, DC Controller PCB (exchange)	C4214-69001 (ex.)	1
3	PCB, Tray, Multi-purpose	RG5-1884-000CN	1
4	PCB, Tray Sensor	RB5-1845-000CN	2



1

Figure 8-9 Face-up Solenoid Assembly

Table 8-9. Face-up Solenoid Assembly

Ref	Description	Part Number	QTY
1	Face-up Solenoid Assembly	RG5-1875-000CN	1

Paper-Handling Devices Parts and Diagrams

Input Devices

2000-sheet Input Tray

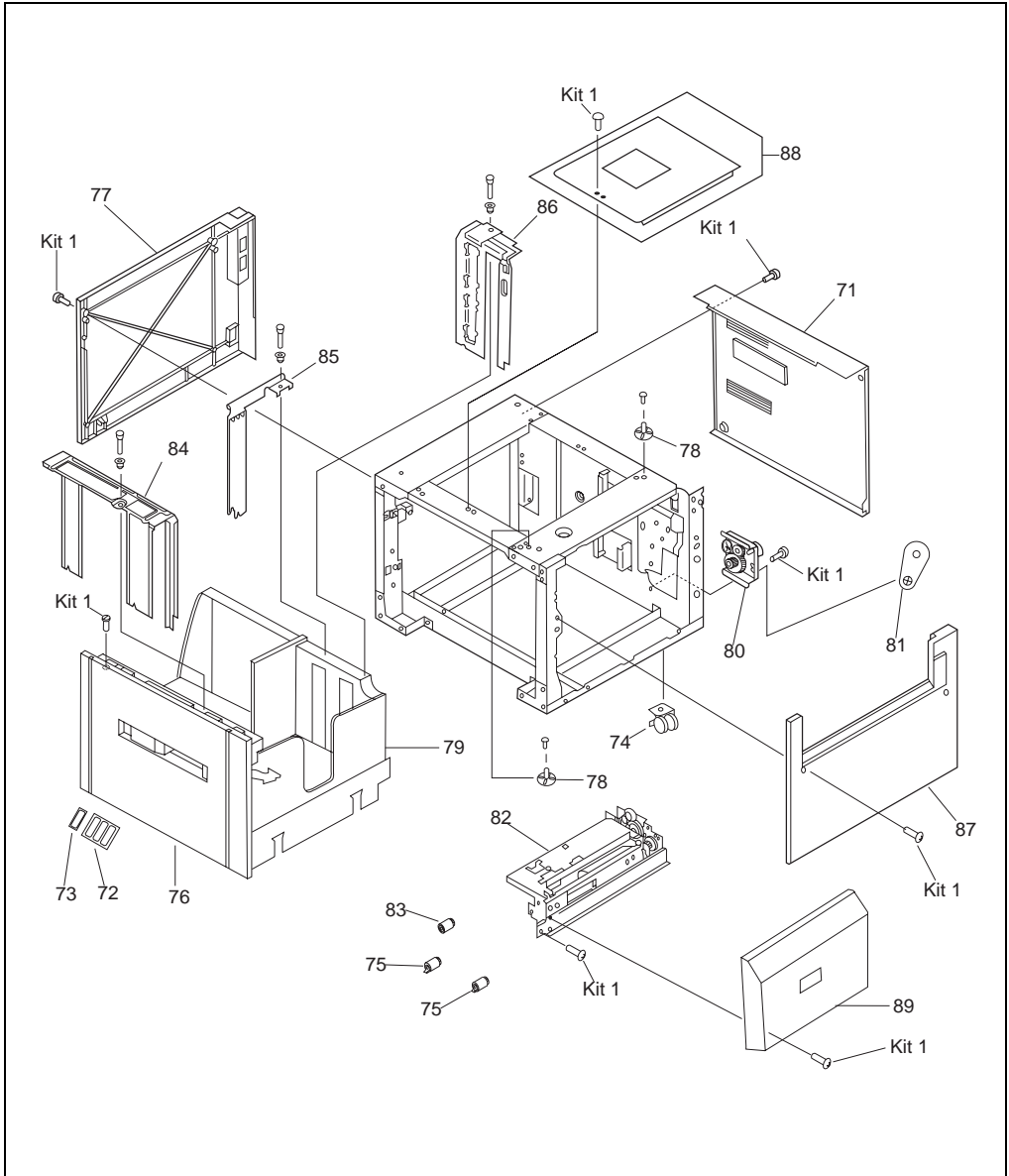

Figure 8-10 2000-sheet Input Tray Components (1 of 2)

Table 8-10. 2000-sheet Input Tray Components (1 of 2)

Ref	Description	Part Number	QTY
71	Back Cover	RB2-2519-000CN	1
72	Tray Size Labels	RS5-8611-000CN	1
73	Tray Size Plate	RB1-6894-000CN	1
74	Caster	XZ9-0442-000CN	4
75	Feed and Separation Rollers	RF5-1834-000CN	2
76	Front Cover (with LED window)	RF5-2568-000CN	1
77	Left Cover	RF5-2646-000CN	1
78	Locating Pin, Metal (Positioning)	RF5-2556-000CN	3
79	2000-sheet Input Tray Paper Tray	RG5-3845-000CN	1
80	Paper Deck Drive Assembly	RG5-3851-000CN	1
81	Paper Deck Drive Bushing	RS5-1399-000CN	1
82	Paper Pickup Assembly	RG5-3843-000CN	1
83	Pickup Roller	RF5-1835-000CN	1
84	Plate Paper Limit Back	RG5-4201-000CN	1
85	Plate Paper Limit Middle	RG5-3849-000CN	1
86	Plate Paper Reference Front	RG5-3850-000CN	1
87	Right Cover	RB1-7832-020CN	1
88	Top Cover (Label Included)	RG5-2644-000CN	1
89	Vertical Transfer Unit (VTU)	RG5-3854-000CN	1
Kit 1	Hardware Kit	RY7-5044-000CN	1

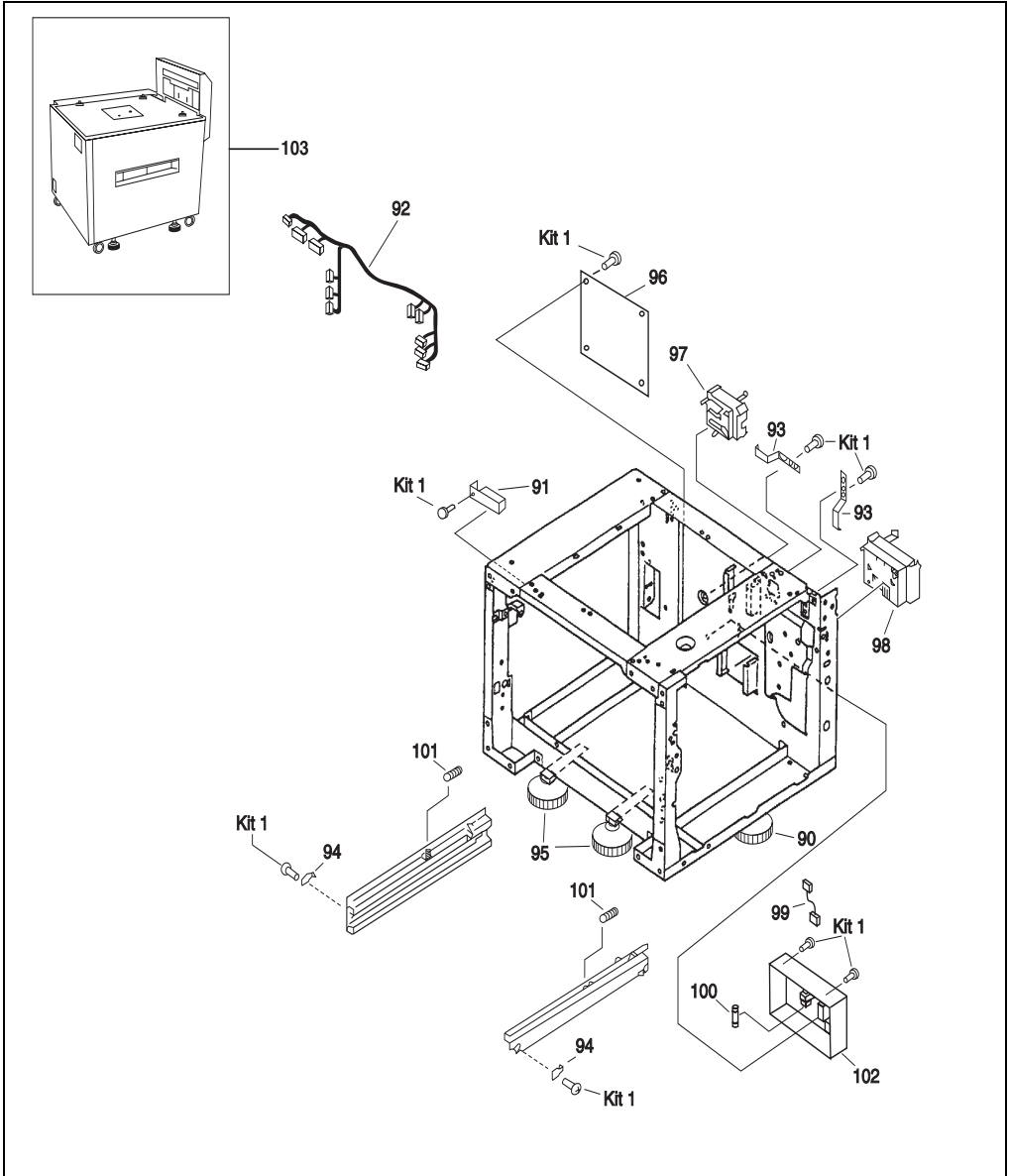

Figure 8-11 2000-sheet Input Tray Components (2 of 2)

Table 8-11. 2000-sheet Input Tray Components (2 of 2)

Ref	Description	Part Number	QTY
90	Feet Adjustable Tip	RG5-3853-000CN	1
91	Front LED PCA with holder and cable	RG5-4204-000CN	1
92	Main Cable	RG5-3919-000CN	1
93	Metal retaining spring (Spring Leaf)	RB1-7835-000CN	1
94	Metallic Retaining Tab (Plate Stop)	RB1-7677-000CN	1
95	Outrigger	RG5-4205-000CN	1
96	Paper Deck PCA (2000-sheet Input Tray Controller)	RG5-3908-000CN	1
97	Paper Quantity Sensor PCA Assembly	RG5-2166-000CN	1
98	Paper Size Sensor PCA Assembly	RG5-2168-000CN	1
99	Power Supply Cable (PSU)	RG5-3909-000CN	1
100	Power Supply Fuse 250V/3.15A	VD7-1893-151CN	1
101	Tension Spring	RS5-2561-000CN	1
102	Universal Power Supply Assembly	RG5-4021-000CN	1
103	2000-sheet Input Tray (whole unit)	R95-3002-000CN	1
Kit 1	2K (2000-sheet Input Tray) Deck Hardware Kit	RY7-5044-000CN	1
Not Shown	Jumper Cable, Long	C4781-60502	1
Not Shown	Jumper Cable, Short	C4781-60501	1
Not Shown	Power Box (includes bracket clip)	C4781-60500	1
Not Shown	Tray Shipping Lock	RB1-7746-000CN	1
Not Shown	C-link Cable (engine to input device)	C3763-60502	1
Not Shown	Clutch cover for 2000-sheet input tray	RB2-2509-000CN	1

2 x 500-sheet Input Tray

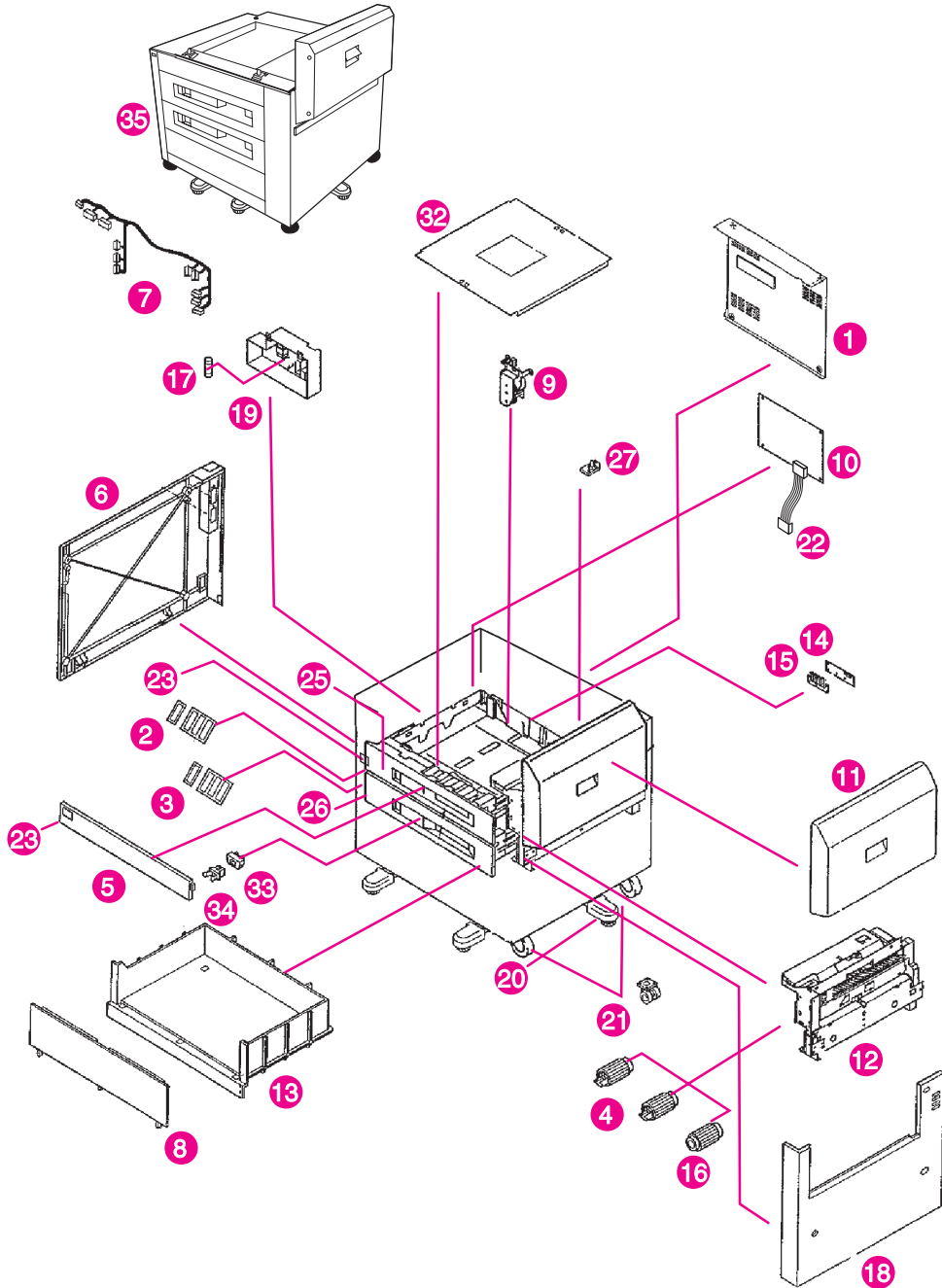

Figure 8-12 2 x 500-sheet Input Tray Internal Components

Table 8-12. 2 x 500-sheet Input Tray Internal Components

Ref	Description	Part Number	QTY
1	Back Cover	RB2-3675-000CN	1
2	Tray Size Labels	RS5-8611-000CN	1
3	Tray Size Plate	RB1-6894-000CN	1
4	Feed and Separation Rollers	RF5-1834-000CN	4
5	Front Top Cover	RF5-2762-000CN	1
6	Left Cover	RF5-2764-000CN	1
7	Main Cable	RG5-4440-000CN	1
8	Front Door (Cover Storage Tray)	RB2-3668-000CN	1
9	Paper Deck Drive Assembly	RG5-4416-000CN	1
10	2 x 500-sheet Input Tray Controller PCA	RG5-4442-000CN	1
11	Paper Feed Assembly (Vertical Transfer Unit)	RG5-4403-000CN	1
12	Paper Pickup Assembly	RG5-4410-000CN	1
13	Storage Paper Tray	RB2-3669-000CN	1
14	Tray-Size Sensing PCA	RG5-1845-000CN	1
15	Holder Size PCA	RB2-3667-000CN	1
16	Pickup Roller	RF5-2708-000CN	1
17	Power Supply Fuse 250V/3.15A	VD7-1893-151CN	1
18	Right Cover	RB2-3666-000CN	1
19	Universal Power Supply Assembly	RG5-4021-000CN	1
20	Outrigger	RG5-4205-000CN	1
21	Caster	XZ9-0442-000CN	1
22	Power Supply Cable (PSU)	RG5-3909-000CN	1
23	Front LED PCA	RG5-4441-000CN	1
25	Tray 4 Assembly	R98-1007-000CN	1
26	Tray 5 Assembly	R98-1006-000CN	1
27	Locating Pin, Metal (Positioning)	RF5-2556-000CN	1
not shown	Power Box (Includes bracket clip)	C4781-60500	1
not shown	Jumper Cable, Short	C4781-60501	1
not shown	Jumper Cable, Long	C4781-60502	1
not shown	Feet Adjustable Tip	RG5-3853-000CN	1
not shown	Clutch cover for 2 x 500-sheet input tray	RB2-3690-000CN	1
32	Top Cover (Includes label)	RF5-2766-000CN	1
33	Spacer, latch	RB2-3705-000CN	1

Table 8-12. 2 x 500-sheet Input Tray Internal Components (continued)

Ref	Description	Part Number	QTY
34	Latch	XZ9-0379-000CN	1
35	2 x 500-sheet Input Tray (whole unit)	R95-3003-000CN	1

Note

All screws are included in the Screws Kit, and all shipping locks are included in the Shipping Locks Kit.

Output Devices

7-bin Tabletop Mailbox

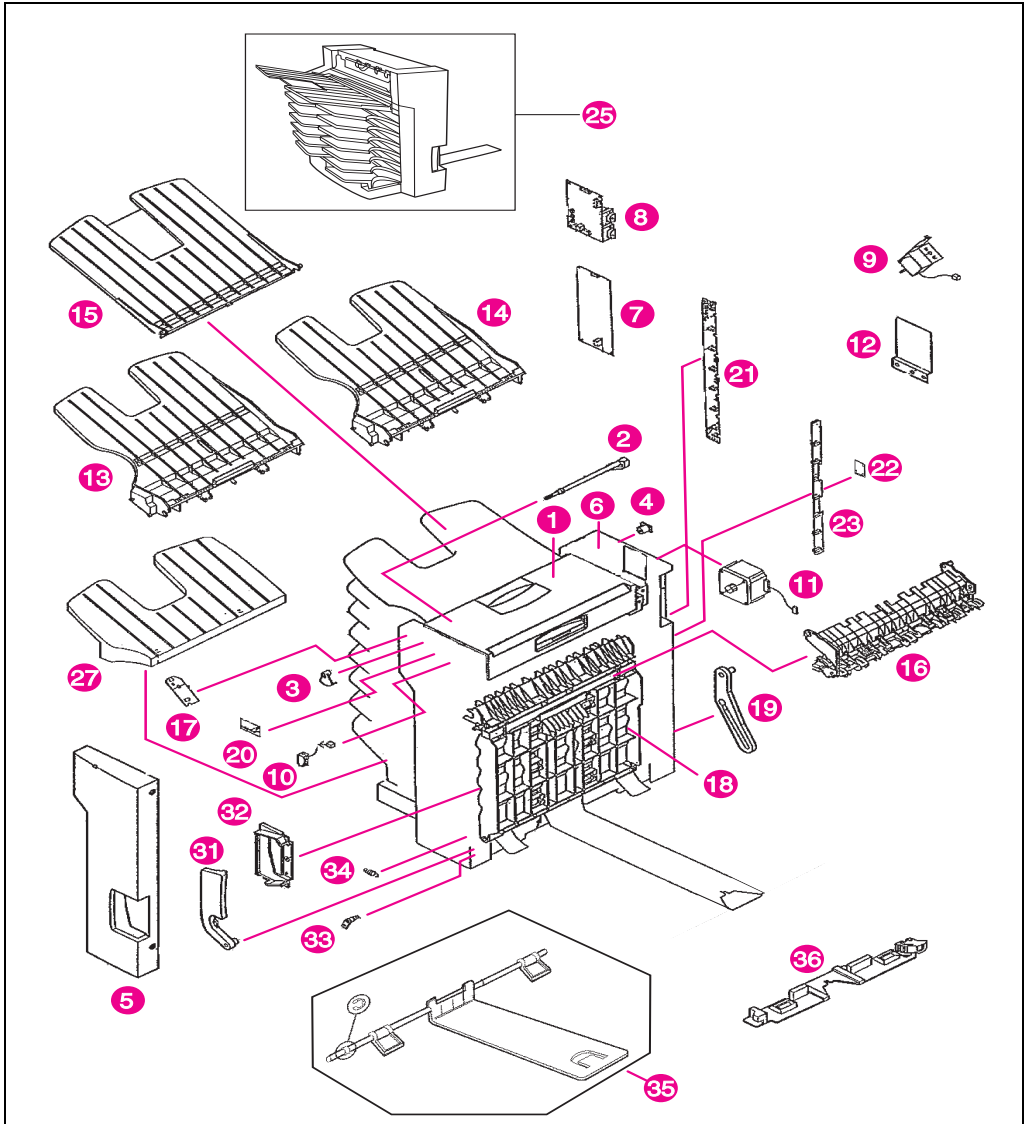

Figure 8-13 7-bin Tabletop Mailbox Internal Components

Table 8-13. 7-bin Tabletop Mailbox Internal Components

Reference	Description	Part Number	QTY
1	Top Cover Assembly (Upper Guide)	RG1-3838-000CN	1
2	Bin Full Sensor	RA2-2484-000CN	1
3	Flag, Sensor	RA2-2485-000CN	1
4	Bushing	RA2-2505-000CN	1
5	Front Cover	RF1-4004-000CN	1
6	Back Cover	RA2-2455-000CN	1
7	Power Supply	RH3-2205-000CN	1
8	7-bin Tabletop Mailbox Controller PCA Assembly	RG1-3853-000CN	1
9	Solenoid Reversing Mechanism	RH7-5223-000CN	1
10	Solenoid Flipper	RH7-5225-000CN	1
11	Reversing Mechanism Motor	RF7-1395-000CN	1
12	Plate (Motor Cover)	RA2-2541-000CN	1
13	Face-down Bin Assembly, Odd (with 1 roller)	RG1-3836-000CN	1
14	Face-down Bin Assembly, Even (with 2 rollers)	RG1-3837-000CN	1
15	Reversing Tray (Face-up)	RA2-2487-000CN	1
16	Diverter Assembly (Flipper)	RG1-3844-000CN	1
17	Face-up Bin Full and Sensor PCA	RG1-3816-000CN	1
18	Right Cover Assembly	RG1-3840-000CN	1
19	Plate, Stopper	RA2-2527-000CN	1
20	LED PCA	RG1-3817-000CN	1
21	Empty Bin Sensor PCA	RG1-3815-000CN	1
22	Support Plate	RA2-2500-000CN	1
23	Full Bin and Interlock sensor PCA	RG1-3814-000CN	1
not shown	C-link Cable (80 cm)	C4783-70000	1
25	7-bin Tabletop Mailbox, whole unit	R95-3007-000CN	1
not shown	7-bin Tabletop Mailbox, Stand Assembly	C4784-60500	1
27	Bottom Bin (Tray)	RA2-2408-000CN	1
31	Handle Latch	RA2-2512-000CN	1
32	Cover Latch	RA2-2531-000CN	1
33	Pin Positioning Bushing	RA2-2439-000CN	1
34	Spring Tension	RA2-2513-000CN	1
35	Rail Assembly	RG1-3842-000CN	1
36	Latching Mechanism	RF1-4005-000CN	1

Table 8-13. 7-bin Tabletop Mailbox Internal Components (continued)

Reference	Description	Part Number	QTY
not shown	Hardware Screws Kit for 7-bin Tabletop Mailbox	RY7-5048-000CN	1

Note All screws are included in the Screws Kit.

8-bin Mailbox

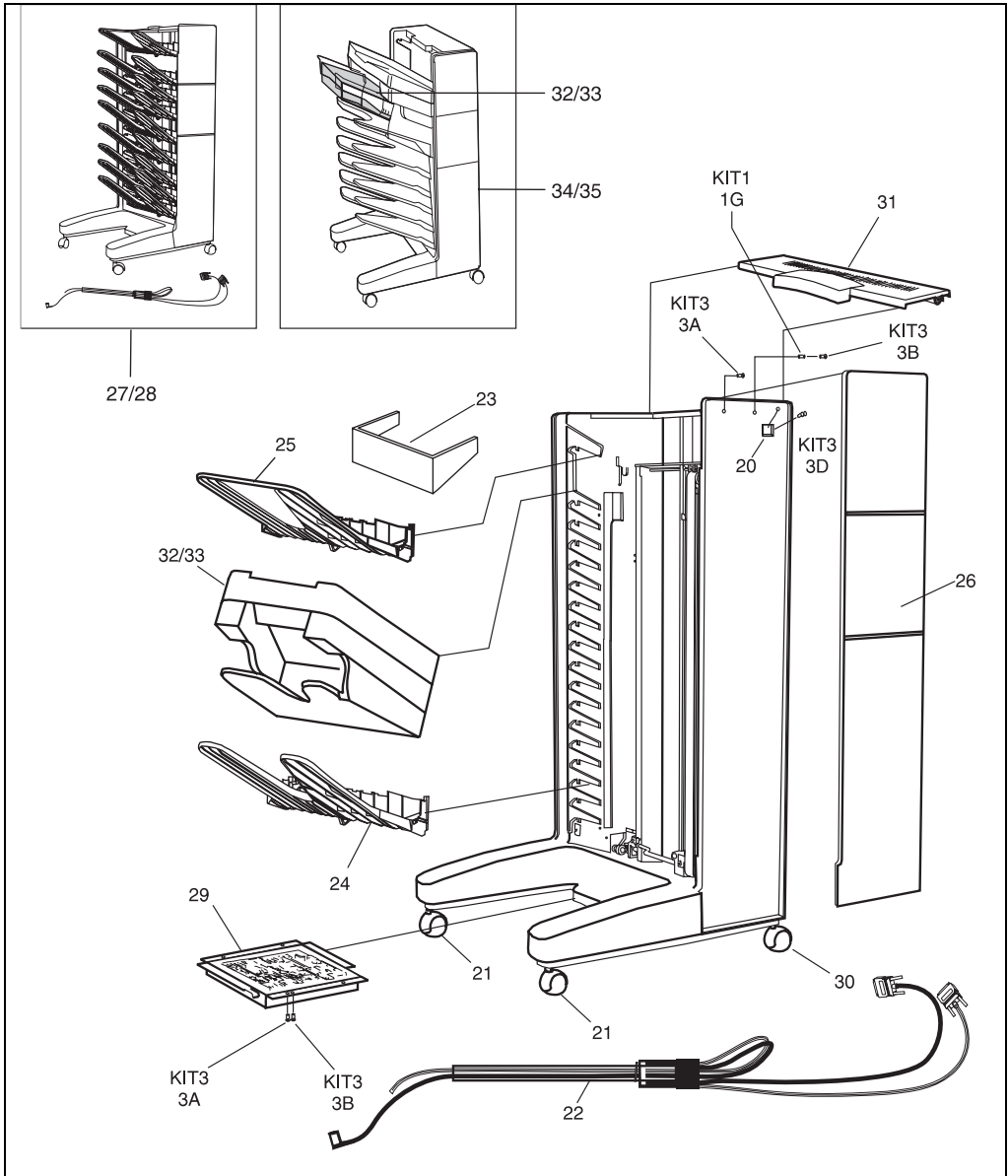

Figure 8-14 8-bin Mailbox Components (1 of 3)

Table 8-14. 8-bin Mailbox Components (1 of 3)

Ref	Description	Part Number	QTY
20	User LED PCA (with Cable)	C4785-60515	1
21	Adjustable Fixed Caster	C4785-60511	1
22	Attachment Assembly (Rod, Bracket, Cables)	C4785-60516	1
23	Blind Cover	C4785-60503	1
24	Standard Output Bin	C4785-60502	1
25	Face-up Bin	C3764-60505	1
26	Front Cover	C4785-60504	1
27	8-bin Mailbox Assembly without attachment rod (Exchange Unit)	C4785-69500 (ex.)	1
28	8-bin Mailbox Assembly with attachment rod (Whole Unit)	C4785-60500	1
29	8-bin Mailbox Controller (with metal box)	C4785-60508	1
30	Nonadjustable Fixed Caster	C4785-60510	1
31	Top Cover	C3764-60555	1
32	Stapler Assembly (Exchange Unit)	C4787-69500 (ex.)	1
33	Stapler Assembly	C4787-60500	1
34	5-bin Mailbox - for Stapler	C4787-60502	1
35	5-bin Mailbox - for Stapler Assembly (Exchange Unit)	C4787-69502 (ex.)	1
Kit 1	Plastic Parts	C4785-60519	1
Kit 1/1G	Spacer, Plastic	(included in Kit 1)	
Kit 3	Hardware	C4785-60521	1
Kit 3/3B	Screws Torx, T20, M4X10	(included in Kit 3)	
Kit 3/3C	Screws Torx, Tapping T20, M4X10	(included in Kit 3)	
Kit 3/3E	Screw Torx, Tapping T10	(included in Kit 3)	

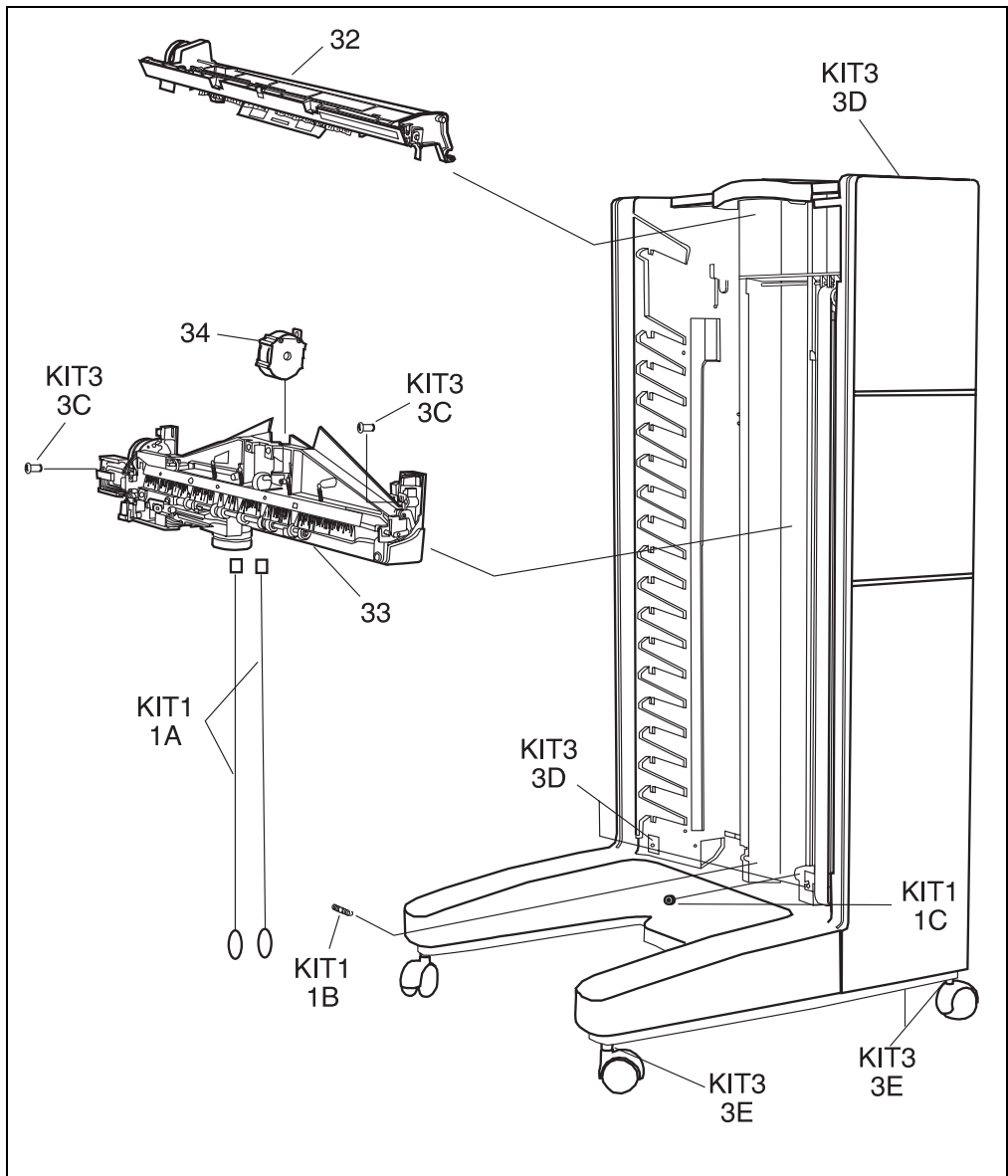

Figure 8-15 8-bin Mailbox Components (2 of 3)

Table 8-15. 8-bin Mailbox Components (2 of 3)

Ref	Description	Part Number	QTY
32	Flipper Assembly	C4785-60509	1
33	Head Assembly (with Metal Tape)	C4785-60506	1
34	Metal Tape and Housing Assembly	C4785-60507	1
Kit 1	Plastic Parts	C4785-60519	1
Kit 1/1A	Anticurl String		
Kit 1/1B	Anticurl Spring		
Kit 1/1C	Pulley, Small Bottom		
Kit 3	Hardware	C4785-60521	1
Kit 3/3D	Screws Torx, T20, M4x12		
Kit 3/3E	Screw Torx, Tapping T10		
Kit 3/3F	Caster Screws		
Not Shown	Repackaging Kit	C4785-60513	1
Not Shown	Short C-link Cable adapter (extension) ¹	C4785-70001	1
Not Shown	C-link Cable 5-bin 8-bin Mailbox to Stapler Unit	C3766-60539	1

1. The extension is necessary when no input device is used in combination with an 8-bin mailbox or a 5-bin mailbox with stapler.

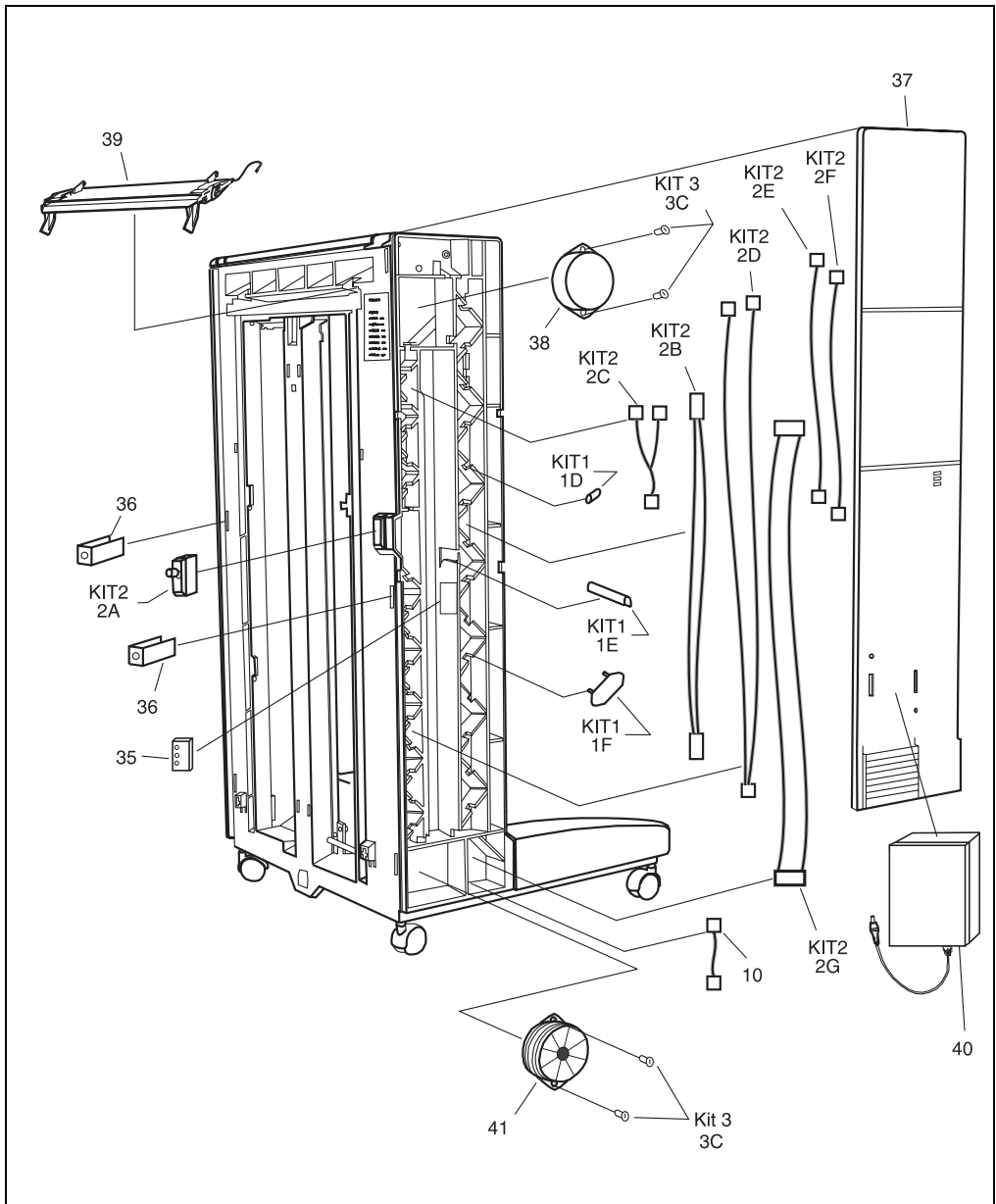

Figure 8-16 8-bin Mailbox Components (3 of 3)

Table 8-16. 8-bin Mailbox Components (3 of 3)

Ref	Description	Part Number	QTY
35	3 Diagnostic LED PCA (with Cable)	C4785-60514	1
36	Attachment Clip	C4785-60512	1
37	Back Cover	C4785-60505	1
38	Delivery Head Position Motor	C3764-60507	1
39	Input Paper Guide (Nose Piece)	C3764-60561	1
40	Power Supply	C4785-60501	1
41	Transport Belt Motor (with Fan)	C4785-60518	1
Kit 1	Plastic Parts	C4785-60519	1
Kit 1/1D	Cable Holder Round Gasket		
Kit 1/1E	Flat Cable holder Edge		
Kit 1/1F	Flat Cable Holder		
Kit 2	Cables	C4785-60520	1
Kit 2/2A	Interlock Switch		
Kit 2/2B	Delivery Head Motor Cable		
Kit 2/2C	Flipper Sensors - Controller Cable		
Kit 2/2D	Flipper Encoder - Controller		
Kit 2/2E	Flipper Motor - Controller		
Kit 2/2AF	ESD Cable		
Kit 2/2G	Delivery Head Assembly Flat Cable		
Kit 3	Hardware	C4785-60521	1
Kit 3/3A	Screws Torx		
Not Shown	Shipping Lock Kit for 8-bin Mailbox/5-bin Mailbox with Stapler	C4787-60503	1

Finisher

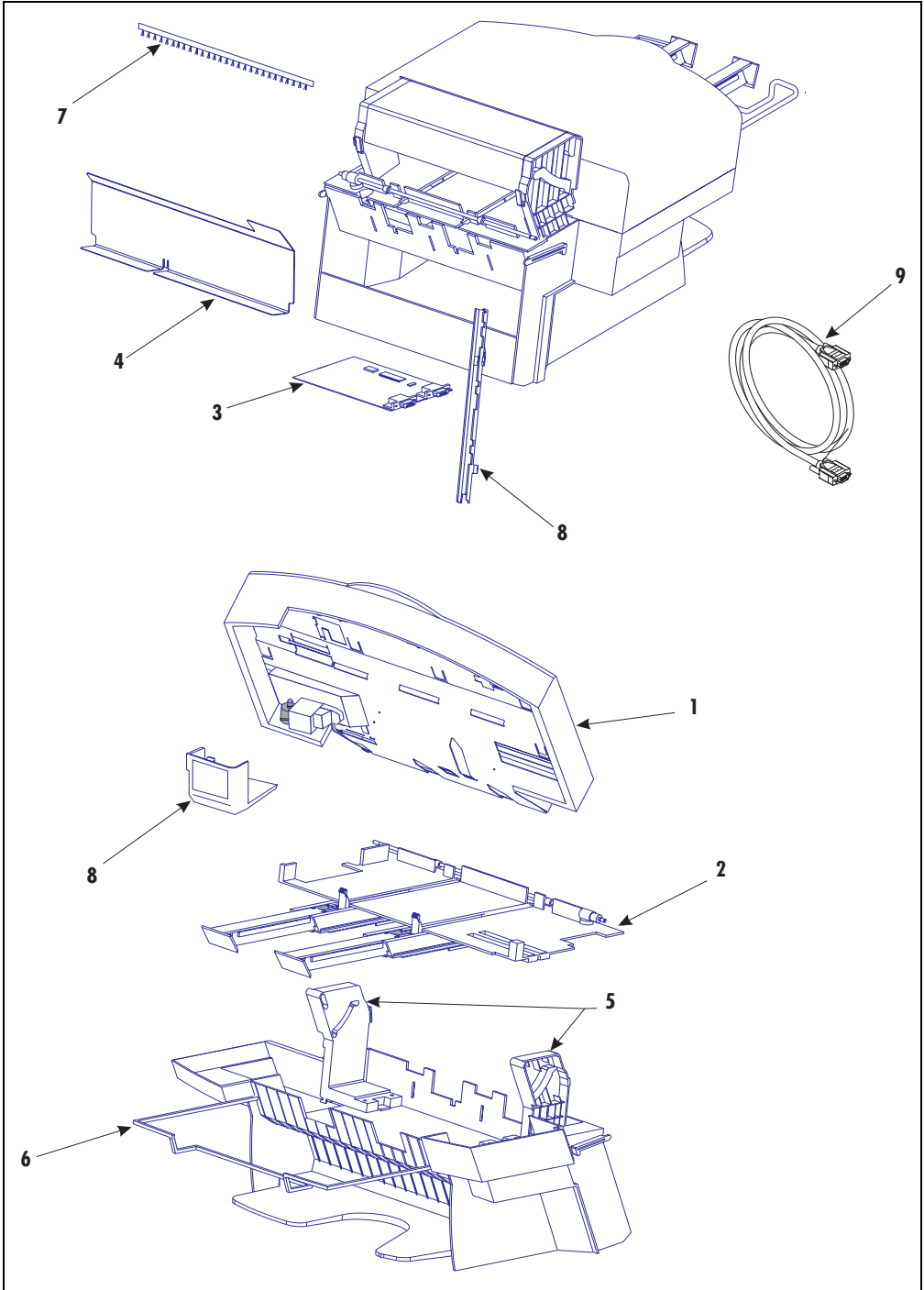

Figure 8-17 Stapler Internal Components

Table 8-17. Stapler Internal Components

Ref	Description	Part Number	QTY
	Stapler Assembly	C4787-60500	1
	Stapler Assembly (Exchange Unit)	C4787-69500 (ex.)	1
1	Top Cover Assembly	C3766-60501	1
2	Stapling Bed Assembly	C3766-60503	1
3	Stapler Control PCA	C4787-60501	1
4	Back Plate	C3766-60505	1
5	Hinges, Set of	C3766-60506	1
6	Wire Frame	C3766-60507	1
7	Brushes	C3766-60508	1
not shown	Stapler Packaging	C3766-60509	1
8	Kit: Plastic staple cover; scan bar (shown) bin full sensor, actuator, and flag (not shown)	C3766-60510	1
not shown	Kit: T10 Torx screws (10)	C3766-60511	1
9	C-link Cable (97 cm)	C3766-60512	1
not shown	Mailbox with Stapler Packaging	C3766-60516	1

Alphabetical Parts List (Mopier and Paper Handling Devices)

Table 8-18. Alphabetical Parts List

Description	Part Number	Table No. and Page
2 x 500-sheet Input Tray (Tray 4 and 5)/C4236A	R95-3003-000CN	Table 8-1 (page 677) Table 8-12 (page 699)
2 x 500-sheet Input Tray Controller PCA	RG5-4442-000CN	Table 8-12 (page 699)
2000-sheet Input Tray (Tray 4)/C4237A	R95-3002-000CN	Table 8-1 (page 677) Table 8-11 (page 697)
2000-sheet Input Tray Paper Tray	RG5-3845-000CN	Table 8-10 (page 695)
2K (2000-sheet Input Tray) Deck Hardware Kit	RY7-5044-000CN	Table 8-11 (page 697)
3 Diagnostic LED PCA (with Cable)	C4785-60514	Table 8-16 (page 711)
5-bin Mailbox - for Stapler	C4787-60502	Table 8-14 (page 707)
5-bin Mailbox - for Stapler Assembly (Exchange Unit)	C4787-69502 (ex.)	Table 8-14 (page 707)
5-bin Mailbox with Stapler/C4241A	C4787-69502 (ex.)	Table 8-1 (page 677)
5-bin Mailbox with Stapler/C4241A (8-bin Mailbox only, without the Stapler Unit.)	C4787-60502	Table 8-1 (page 677)
7-bin Tabletop Mailbox Controller PCA Assembly	RG1-3853-000CN	Table 8-13 (page 703)
7-bin Tabletop Mailbox, Stand Assembly	C4784-60500	Table 8-13 (page 703)
7-bin Tabletop Mailbox/C4238A	R95-3007-000CN	Table 8-1 (page 677) Table 8-13 (page 703)
8-bin Mailbox/C4240B		Table 8-1 (page 677)
Adjustable Fixed Caster	C4785-60511	Table 8-14 (page 707)
Arm, Sensor-PS2	RB1-6557-000CN	Table 8-7 (page 691)
Arm-Pressure-front	RB1-6444-000CN	Table 8-4 (page 685)
Assembly, DC Controller PCB	RG5-4375-000CN	Table 8-8 (page 692)
Assembly, DC Controller PCB (exchange)	C4214-69001 (ex.)	Table 8-8 (page 692)
Assembly, Laser Scanner	RG5-4344-000CN	Table 8-5 (page 687)
Assembly, Laser Scanner (exchange)	C4214-69003 (ex.)	Table 8-5 (page 687)
Assembly, MP Tray (Tray 1)	RG5-4330-000CN	Table 8-7 (page 691)
Assembly, Paper Pickup	RG5-4334-000CN	Table 8-7 (page 691)
Assembly, Transfer Roller	RG5-4304-000CN	Table 8-3 (page 683)
Attachment Assembly (Rod, Bracket, Cables)	C4785-60516	Table 8-14 (page 707)

Table 8-18. Alphabetical Parts List (continued)

Description	Part Number	Table No. and Page
Attachment Clip	C4785-60512	Table 8-16 (page 711)
Back Cover, 8-bin Mailbox	C4785-60505	Table 8-16 (page 711)
Back Cover, 7-bin Tabletop Mailbox	RA2-2455-000CN	Table 8-13 (page 703)
Back Cover, 2000-sheet Input Tray	RB2-2519-000CN	Table 8-10 (page 695)
Back Cover, 2 x 500-sheet Input Tray	RB2-3675-000CN	Table 8-12 (page 699)
Back Plate	C3766-60505	Table 8-17 (page 713)
Bin Full Sensor	RA2-2484-000CN	Table 8-13 (page 703)
Blind Cover	C4785-60503	Table 8-14 (page 707)
Block, Shaft Holding, Front	RB2-3503-000CN	Table 8-7 (page 691)
Block, Shaft Holding, Rear	RB2-3504-000CN	Table 8-7 (page 691)
Bottom Bin (Tray)	RA2-2408-000CN	Table 8-13 (page 703)
Brushes	C3766-60508	Table 8-17 (page 713)
Bushing	RA2-2505-000CN	Table 8-13 (page 703)
C-link Cable (61 cm) (engine to input device)	C3763-60502	Table 8-1 (page 677) Table 8-11 (page 697)
C-link Cable (80 cm)	C4783-70000	Table 8-13 (page 703)
C-link Cable (97 cm)	C3766-60512	Table 8-17 (page 713)
C-link Cable Assembly 97 cm (8-bin Mailbox to Stapler)	C3766-60539	Table 8-1 (page 677) Table 8-15 (page 709)
Cable, Fan 1	RG5-1921-000CN	Table 8-6 (page 689)
Cable, Fuser 1	RG5-4381-000CN	Table 8-6 (page 689)
Cable, Fuser 2	RG5-1850-000CN	Table 8-6 (page 689)
Cable, Paper Pickup	RG5-1861-000CN	Table 8-7 (page 691)
Cable, Registration	RG5-1928-000CN	Table 8-6 (page 689)
Cable, Scanner Motor	RG5-4378-000CN	Table 8-5 (page 687)
Cable, Sensor	RG5-1859-000CN	Table 8-7 (page 691)
Cable, Tray Sensor	RG5-1920-000CN	Table 8-4 (page 685)
Cables	C4785-60520	Table 8-16 (page 711)
Caster	XZ9-0442-000CN	Table 8-10 (page 695) Table 8-12 (page 699)
Clutch Cover	RB2-3631-000CN	Table 8-3 (page 683)
Clutch cover for 2 x 500-sheet input tray	RB2-3690-000CN	Table 8-12 (page 699)
Clutch cover for 2000-sheet input tray	RB2-2509-000CN	Table 8-11 (page 697)
Clutch, Paper Feed	RH7-5188-000CN	Table 8-7 (page 691)

Table 8-18. Alphabetical Parts List (continued)

Description	Part Number	Table No. and Page
Compression Spring, Front	RS6-2072-000CN	Table 8-7 (page 691)
Compression Spring, Rear	RS6-2073-000CN	Table 8-7 (page 691)
Cover Latch	RA2-2531-000CN	Table 8-13 (page 703)
Cover, Internal Tray	RB1-6749-000CN	Table 8-3 (page 683)
Cover, Left-Lower	RB1-6480-000CN	Table 8-2 (page 681)
Cover, Rear	RF5-1402-000CN	Table 8-2 (page 681)
Cover, Switch	RB1-6492-000CN	Table 8-2 (page 681)
Cover, Upper Right	RB1-6464-000CN	Table 8-4 (page 685)
Delivery Assembly	RG5-1874-000CN	Table 8-7 (page 691)
Delivery Cover (Left Side F/U)	RB2-3558-000CN	Table 8-2 (page 681)
Delivery Head Position Motor	C3764-60507	Table 8-16 (page 711)
Display, Control Panel	RG5-4384-000CN	Table 8-2 (page 681)
Diverter Assembly	RG5-4325-000CN	Table 8-2 (page 681)
Diverter Assembly (Flipper)	RG1-3844-000CN	Table 8-13 (page 703)
Diverter Drive Assembly	RF9-1249-000CN	Table 8-2 (page 681)
Duplexer/C4782A	C4782-60501 C4782-69501 (ex.)	Table 8-1 (page 677)
EIO Coverplate	5182-5899	Table 8-1 (page 677)
Electrical Cover (Rear by Formatter)	RB1-6489-000CN	Table 8-2 (page 681)
Electromagnetic Clutch	RH7-5187-000CN	Table 8-3 (page 683)
Empty Bin Sensor PCA	RG1-3815-000CN	Table 8-13 (page 703)
Envelope Feeder/C4242B	C3765-60501	Table 8-1 (page 677)
Face-down Bin Assembly, Even (with 2 rollers)	RG1-3837-000CN	Table 8-13 (page 703)
Face-down Bin Assembly, Odd (with 1 roller)	RG1-3836-000CN	Table 8-13 (page 703)
Face-down Delivery Assembly	RG5-1874-000CN	Table 8-3 (page 683)
Face-up Bin (8-bin Mailbox)	C3764-60505	Table 8-14 (page 707)
Face-up Bin (engine)	RB1-6491-000CN	Table 8-1 (page 677)
Face-up Bin Full and Sensor PCA	RG1-3816-000CN	Table 8-13 (page 703)
Face-up Solenoid Assembly	RG5-1875-000CN	Table 8-9 (page 693)
Fan, FM1/Low Voltage Power Supply	RH7-1396-000CN	Table 8-6 (page 689)
Fan, FM2/Laser Scanner	RH7-1266-000CN	Table 8-5 (page 687)
Fan, FM3/ Formatter	RH7-1271-000CN	Table 8-6 (page 689)
Fan, FM4/Delivery Assembly	RH7-1289-000CN	Table 8-7 (page 691)

Table 8-18. Alphabetical Parts List (continued)

Description	Part Number	Table No. and Page
Fan, FM5	RH7-1397-000CN	Table 8-7 (page 691)
Feed and Separation Rollers	RF5-1834-000CN	Table 8-10 (page 695) Table 8-12 (page 699)
Feeder Assembly	RG5-4305-000CN	Table 8-3 (page 683) Table 8-7 (page 691)
Feet Adjustable Tip	RG5-3853-000CN	Table 8-11 (page 697) Table 8-12 (page 699)
Flag, Sensor	RA2-2485-000CN	Table 8-13 (page 703)
Flipper Assembly	C4785-60509	Table 8-15 (page 709)
Foot	RB1-6421-000CN	Table 8-4 (page 685)
Formatter Assembly	C4107-67901	Table 8-1 (page 677)
Formatter Assembly, Exchange	C4107-69001 (ex.)	Table 8-1 (page 677)
Front Cover, 8-bin Mailbox	C4785-60504	Table 8-14 (page 707)
Front Cover, 7-bin Tabletop Mailbox	RF1-4004-000CN	Table 8-13 (page 703)
Front Cover, engine	RG5-4362-000CN	Table 8-2 (page 681)
Front Cover (Duplex Jam Removal)	RB2-3626-000CN	Table 8-2 (page 681)
Front Cover (with LED window)	RF5-2568-000CN	Table 8-10 (page 695)
Front Door (Cover Storage Tray)	RB2-3668-000CN	Table 8-12 (page 699)
Front LED PCA	RG5-4441-000CN	Table 8-12 (page 699)
Front LED PCA with holder and cable	RG5-4204-000CN	Table 8-11 (page 697)
Front Top Cover	RF5-2762-000CN	Table 8-12 (page 699)
Full Bin and Interlock sensor PCA	RG1-3814-000CN	Table 8-13 (page 703)
Fuser Lock Lever-Left	RB1-6616-020CN	Table 8-3 (page 683)
Fuser Lock Lever-Right	RB1-6615-020CN	Table 8-3 (page 683)
Fusing Assembly, 110V	RG5-4315-000CN	Table 8-3 (page 683)
Fusing Assembly, 220V	RG5-4317-000CN	Table 8-3 (page 683)
Fusing Assembly, 110V (ex.)	C4214-69007	Table 8-3 (page 683)
Fusing Assembly, 220V (ex.)	C4214-69008	Table 8-3 (page 683)
Gear, 20T	RS5-1127-000CN	Table 8-2 (page 681)
Guide, Front	RB2-3622-000CN	Table 8-4 (page 685)
Guide, Rail	RB1-6776-000CN	Table 8-4 (page 685)
Guide, Rear	RF5-2726-000CN	Table 8-4 (page 685)
Guide, Slide	RB1-6775-000CN	Table 8-6 (page 689)
Guides, Interface	RB1-6771-000CN	Table 8-6 (page 689)

Table 8-18. Alphabetical Parts List (continued)

Description	Part Number	Table No. and Page
Handle Latch	RA2-2512-000CN	Table 8-13 (page 703)
Hardware	C4785-60521	Table 8-14 (page 707) Table 8-15 (page 709) Table 8-16 (page 711)
Hardware Kit	RY7-5044-000CN	Table 8-10 (page 695)
Hardware Screws Kit for 7-bin Tabletop Mailbox	RY7-5048-000CN	Table 8-13 (page 703)
Head Assembly (with Metal Tape)	C4785-60506	Table 8-15 (page 709)
High-Voltage Power Supply	RG5-4306-000CN	Table 8-5 (page 687)
Hinge Plate	RB2-3641-000CN	Table 8-2 (page 681)
Hinge, Stopper	RF5-2701-000CN	Table 8-2 (page 681)
Hinges, Set of	C3766-60506	Table 8-17 (page 713)
Holder Size PCA	RB2-3667-000CN	Table 8-12 (page 699)
Holder, Damper-Front	RB1-6461-000CN	Table 8-3 (page 683)
Holder, Damper-Rear	RB1-6462-000CN	Table 8-3 (page 683)
Input Paper Guide (Nose Piece)	C3764-60561	Table 8-16 (page 711)
Jumper Cable, Long	C4781-60502	Table 8-1 (page 677) Table 8-11 (page 697) Table 8-12 (page 699)
Jumper Cable, Short	C4781-60501	Table 8-1 (page 677) Table 8-11 (page 697) Table 8-12 (page 699)
Kit: Plastic staple cover; scan bar bin full sensor, actuator, and flag	C3766-60510	Table 8-17 (page 713)
Kit: T10 Torx screws (10)	C3766-60511	Table 8-17 (page 713)
Label, Operation	RS5-8676-000CN	Table 8-2 (page 681)
Laser and Control Panel Cable	RG5-4377-000CN	Table 8-5 (page 687)
Latch	XZ9-0379-000CN	Table 8-12 (page 699)
Latching Mechanism	RF1-4005-000CN	Table 8-13 (page 703)
LED PCA	RG1-3817-000CN	Table 8-13 (page 703)
Left Cover, 2000-sheet Input Tray	RF5-2646-000CN	Table 8-10 (page 695)
Left Cover, 2 x 500-sheet Input Tray	RF5-2764-000CN	Table 8-12 (page 699)
Limiter, torque	RB2-3581-000CN	Table 8-7 (page 691)
Locating Pin, Metal (Positioning)	RF5-2556-000CN	Table 8-10 (page 695) Table 8-12 (page 699)
Mailbox with Stapler Packaging	C3766-60516	Table 8-17 (page 713)
Main Cable, 2000-sheet Input Tray	RG5-3919-000CN	Table 8-11 (page 697)

Table 8-18. Alphabetical Parts List (continued)

Description	Part Number	Table No. and Page
Main Cable, 2 x 500-sheet Input Tray	RG5-4440-000CN	Table 8-12 (page 699)
Main Motor	RH7-5219-000CN	Table 8-3 (page 683)
Main Motor Cable	RG5-4386-000CN	Table 8-3 (page 683)
Maintenance Kit, 100-120V/C3914A	C3914-69001 (ex.)	Table 8-1 (page 677)
Maintenance Kit, 220-240V/C3915A	C3915-69001 (ex.)	Table 8-1 (page 677)
Metal retaining spring (Spring Leaf)	RB1-7835-000CN	Table 8-11 (page 697)
Metal Tape and Housing Assembly	C4785-60507	Table 8-15 (page 709)
Metallic Retaining Tab (Plate Stop)	RB1-7677-000CN	Table 8-11 (page 697)
Motor, PIU	RH7-1350-000CN	Table 8-7 (page 691)
MP Separation Pad	RF5-2703-000CN	Table 8-7 (page 691)
MP Tray Assembly Cover (Tray 1)	RG5-4329-000CN	Table 8-3 (page 683)
Multi-purpose Tray Assembly (Tray 1)	RG5-4330-000CN	Table 8-3 (page 683)
Multi-Purpose Tray Feed Roller (Tray 1)	RB1-9526-000CN	Table 8-7 (page 691)
8-bin Mailbox Assembly with attachment rod (Whole Unit)	C4785-60500	Table 8-14 (page 707)
8-bin Mailbox Assembly without attachment rod (Exchange Unit)	C4785-69500 (ex.)	Table 8-14 (page 707)
8-bin Mailbox Controller (with metal box)	C4785-60508	Table 8-14 (page 707)
Nonadjustable Fixed Caster	C4785-60510	Table 8-14 (page 707)
Open/Close Stopper	RB1-6484-000CN	Table 8-2 (page 681)
Outrigger, 2 x 500-sheet Input Tray	RG5-3852-000CN	Table 8-12 (page 699)
Outrigger, 2000-sheet Input Tray	RG5-4205-000CN	Table 8-11 (page 697)
Packaging Kit, 2000-sheet Input Tray	C3763-60500	Table 8-1 (page 677)
Overlay, Control Panel (English)	C4214-40029	Table 8-2 (page 681)
Overlay, Control Panel (French)	C4214-40030	Table 8-2 (page 681)
Overlay, Control Panel (German)	C4214-40041	Table 8-2 (page 681)
Overlay, Control Panel (Italian)	C4214-40031	Table 8-2 (page 681)
Overlay, Control Panel (Portuguese)	C4214-40032	Table 8-2 (page 681)
Overlay, Control Panel (Spanish)	C4214-40042	Table 8-2 (page 681)
Packaging Kit, duplexer	C3762-60500	Table 8-1 (page 677)
Packaging Kit, Envelope Feeder	C3765-60500	Table 8-1 (page 677)
Packaging Kit, 8-bin Mailbox	C3764-60500	Table 8-1 (page 677)
Packaging Kit, Printer	5041-9238	Table 8-1 (page 677)
Paper Deck Drive Assembly, 2000-sheet Input Tray	RG5-3851-000CN	Table 8-10 (page 695)

Table 8-18. Alphabetical Parts List (continued)

Description	Part Number	Table No. and Page
Paper Deck Drive Assembly, 2 x 500-sheet Input Tray	RG5-4416-000CN	Table 8-12 (page 699)
Paper Deck Drive Bushing	RS5-1399-000CN	Table 8-10 (page 695)
Paper Deck PCA (2000-sheet Input Tray Controller)	RG5-3908-000CN	Table 8-11 (page 697)
Paper Feed Assembly (Vertical Transfer Unit)	RG5-4403-000CN	Table 8-12 (page 699)
Paper Height Lever	RB1-6693-000CN	Table 8-7 (page 691)
Paper Input Unit (PIU)	RG5-4434-000CN	Table 8-3 (page 683)
Paper Input Unit (PIU) (ex.)	C4214-69004	Table 8-3 (page 683)
Paper Pickup Assembly, 2000-sheet Input Tray	RG5-3843-000CN	Table 8-10 (page 695)
Paper Pickup Assembly, 2 x 500-sheet Input Tray	RG5-4410-000CN	Table 8-12 (page 699)
Paper Quantity Sensor PCA Assembly	RG5-2166-000CN	Table 8-11 (page 697)
Paper Sensing Lever	RB1-6692-000CN	Table 8-7 (page 691)
Paper Size Guide (Trays 2 and 3)	RF5-1484-000CN	Table 8-1 (page 677)
Paper Size Guide Label (Trays 2 and 3)	RS5-8605-000CN	Table 8-1 (page 677)
Paper Size Sensor PCA Assembly	RG5-2168-000CN	Table 8-11 (page 697)
PCA, PIU	RG5-1860-000CN	Table 8-7 (page 691)
PCB, Switch/Sensor	RG5-1846-000CN	Table 8-8 (page 692)
PCB, Tray Sensor	RB5-1845-000CN	Table 8-8 (page 692)
PCB, Tray, Multi-purpose	RG5-1884-000CN	Table 8-8 (page 692)
Photo Interrupter	WG8-0291-000CN	Table 8-7 (page 691)
Pickup Roller, 2000-sheet Input Tray	RF5-1835-000CN	Table 8-10 (page 695)
Pickup Roller, 2 x 500-sheet Input Tray	RF5-2708-000CN	Table 8-12 (page 699)
Pin Positioning Bushing	RA2-2439-000CN	Table 8-13 (page 703)
Plastic Parts	C4785-60519	Table 8-14 (page 707) Table 8-15 (page 709) Table 8-16 (page 711)
Plate (Motor Cover)	RA2-2541-000CN	Table 8-13 (page 703)
Plate Paper Limit Back	RG5-4201-000CN	Table 8-10 (page 695)
Plate Paper Limit Middle	RG5-3849-000CN	Table 8-10 (page 695)
Plate Paper Reference Front	RG5-3850-000CN	Table 8-10 (page 695)
Plate, Guide-Upper	RB1-6582-000CN	Table 8-7 (page 691)
Plate, Stopper	RA2-2527-000CN	Table 8-13 (page 703)

Table 8-18. Alphabetical Parts List (continued)

Description	Part Number	Table No. and Page
Power Box (Includes bracket clip)	C4781-60500	Table 8-1 (page 677) Table 8-11 (page 697) Table 8-12 (page 699)
Power Supply (8-bin Mailbox)	C4785-60501	Table 8-16 (page 711)
Power Supply (7-bin Tabletop Mailbox)	RH3-2205-000CN	Table 8-13 (page 703)
Power Supply Cable (PSU)	RG5-3909-000CN	Table 8-11 (page 697) Table 8-12 (page 699)
Power Supply Fuse 250V/3.15A	VD7-1893-151CN	Table 8-11 (page 697) Table 8-12 (page 699)
Power Supply, Low Voltage-220 V	RG5-4301-000CN	Table 8-6 (page 689)
Power Supply, Low-Voltage 110 V	RG5-4300-000CN	Table 8-6 (page 689)
Printer Drive Assembly	RG5-4365-000CN	Table 8-3 (page 683)
Rail Assembly	RA2-3842-000CN	Table 8-13 (page 703)
Registration Assembly	RG5-4303-000CN	Table 8-3 (page 683)
Release, Arm	RB1-6446-000CN	Table 8-4 (page 685)
Repackaging Kit	C4785-60513	Table 8-15 (page 709)
Reversing Mechanism Motor	RF7-1395-000CN	Table 8-13 (page 703)
Reversing Tray (Face-up)	RA2-2487-000CN	Table 8-13 (page 703)
Right Cover, 2000-sheet Input Tray	RB1-7832-020CN	Table 8-10 (page 695)
Right Cover, 2 x 500-sheet Input Tray	RB2-3666-000CN	Table 8-12 (page 699)
Right Cover Assembly, 7-bin Tabletop Mailbox	RG1-3840-000CN	Table 8-13 (page 703)
Right Cover Assembly, engine	RG5-1915-000CN	Table 8-2 (page 681)
Right, Lower Cover (Rear Plastic on Sheet Metal)	RB2-3642-000CN	Table 8-2 (page 681)
ROD	RB1-6778-000CN	Table 8-4 (page 685)
Rollers, Feed and Separation	RF5-1834-000CN	Table 8-7 (page 691)
Roller, Pickup	RF5-2708-000CN	Table 8-7 (page 691)
Roller, Transfer	RF5-2675-000CN	Table 8-3 (page 683)
Screw, M3 x 8	XA9-0872-000CN	Table 8-2 (page 681)
Screw, M4 x 10	XA9-0870-000CN	Table 8-2 (page 681)
Screw, M4 x 8	XA9-0605-000CN	Table 8-2 (page 681)
Screw, M4 x 8 TP	XB6-7400-807CN	Table 8-3 (page 683)
Sensor Arm PS1	RB1-6417-000CN	Table 8-7 (page 691)
Sensor Arm Spring	RB1-6409-000CN	Table 8-7 (page 691)
Sensor Cable	RG5-1843-000CN	Table 8-7 (page 691)

Table 8-18. Alphabetical Parts List (continued)

Description	Part Number	Table No. and Page
Shield, Formatter	RF5-2678-000CN	Table 8-6 (page 689)
Shield, Plate	RF5-1464-000CN	Table 8-6 (page 689)
Shipping Lock Kit for 8-bin Mailbox/5-bin Mailbox with Stapler	C4787-60503	Table 8-16 (page 711)
Short C-link Cable adapter	C4785-70001	Table 8-15 (page 709)
Shutter, White	RB1-6473-000CN	Table 8-5 (page 687)
Solenoid Flipper	RH7-5225-000CN	Table 8-13 (page 703)
Solenoid Reversing Mechanism	RH7-5223-000CN	Table 8-13 (page 703)
Spacer, latch	RB2-3705-000CN	Table 8-12 (page 699)
Spring, Compression	RB1-6493-000CN	Table 8-2 (page 681)
Spring, Torsion	RB1-6509-000CN	Table 8-2 (page 681)
Spring Tension	RA2-2513-000CN	Table 8-13 (page 703)
Spring, Sensor Arm	RB1-6558-000CN	Table 8-7 (page 691)
Spring, Tension	RS5-2499-000CN	Table 8-4 (page 685)
Stand for 7-bin Tabletop Mailbox/C4239A	C4784-60500	Table 8-1 (page 677)
Standard Output Bin	C4785-60502	Table 8-14 (page 707)
Stapler Assembly	C4787-60500	Table 8-1 (page 677) Table 8-14 (page 707) Table 8-17 (page 713)
Stapler Assembly (Exchange Unit)	C4787-69500 (ex.)	Table 8-14 (page 707) Table 8-17 (page 713)
Stapler Cartridges (3-pack)/C3772A		Table 8-1 (page 677)
Stapler Control PCA	C4787-60501	Table 8-17 (page 713)
Stapler Packaging	C3766-60509	Table 8-17 (page 713)
Stapling Bed Assembly	C3766-60503	Table 8-17 (page 713)
Stopper, CG	RB1-6427-000CN	Table 8-5 (page 687)
Stopper, Rail	RB1-6777-000CN	Table 8-4 (page 685)
Stopper, Rail	RB1-6783-000CN	Table 8-4 (page 685)
Storage Paper Tray	RB2-3669-000CN	Table 8-12 (page 699)
Support Plate	RA2-2500-000CN	Table 8-13 (page 703)
Tension Spring	RS5-2561-000CN	Table 8-11 (page 697)
Toner Cartridge/C4182X		Table 8-1 (page 677)
Top Cover, 8-bin Mailbox	C3764-60555	Table 8-14 (page 707)
Top Cover (Includes label), 2 x 500-sheet Input Tray	RF5-2766-000CN	Table 8-12 (page 699)

Table 8-18. Alphabetical Parts List (continued)

Description	Part Number	Table No. and Page
Top Cover (Label Included), 2000-sheet Input Tray	RG5-2644-000CN	Table 8-10 (page 695)
Top Cover Assembly (Engine)	RG5-4360-000CN	Table 8-2 (page 681)
Top Cover Assembly, stapler	C3766-60501	Table 8-17 (page 713)
Top Cover Assembly (Upper Guide), 7-bin Tabletop Mailbox	RG1-3838-000CN	Table 8-13 (page 703)
Transfer Guide	RF5-2676-000CN	Table 8-3 (page 683)
Transfer Guide Bushing	RB1-6441-000CN	Table 8-3 (page 683)
Transport Belt Motor (with Fan)	C4785-60518	Table 8-16 (page 711)
Tray 2	RG5-3951-000CN	Table 8-1 (page 677)
Tray 3	RG5-3952-000CN	Table 8-1 (page 677)
Tray 4 Assembly	R98-1007-000CN	Table 8-12 (page 699)
Tray 5 Assembly	R98-1006-000CN	Table 8-12 (page 699)
Tray Shipping Lock	RB1-7746-000CN	Table 8-11 (page 697)
Tray Size Labels	RS5-8611-000CN	Table 8-10 (page 695) Table 8-12 (page 699)
Tray Size Plate	RB1-6894-000CN	Table 8-10 (page 695) Table 8-12 (page 699)
Tray, Face-up	RB1-6491-000CN	Table 8-2 (page 681)
Tray, Output-Face-down	RB1-6490-000CN	Table 8-2 (page 681)
Tray-Size Sensing PCA	RG5-1845-000CN	Table 8-12 (page 699)
Universal Power Supply Assembly	RG5-4021-000CN	Table 8-11 (page 697) Table 8-12 (page 699)
User LED PCA (with Cable)	C4785-60515	Table 8-14 (page 707)
Vertical Transfer Unit (VTU)	RG5-3854-000CN	Table 8-10 (page 695)
Wire Frame	C3766-60507	Table 8-17 (page 713)

Numerical Parts List (Mopier and Paper Handling Devices)

Table 8-19. Numerical Parts List

Part Number	Description	Table No. and Page
	Stapler Cartridges (3-pack)/C3772A	Table 8-1 (page 677)
	Toner Cartridge/C4182X	Table 8-1 (page 677)
5041-9238	Packaging Kit, Printer	Table 8-1 (page 677)
5182-5899	EIO Coverplate	Table 8-1 (page 677)
C3762-60500	Packaging Kit, duplexer	Table 8-1 (page 677)
C3763-60500	Packaging Kit, 2000-sheet Input Tray	Table 8-1 (page 677)
C3763-60502	C-link Cable (61 cm) (engine to input device)	Table 8-1 (page 677) Table 8-11 (page 697)
C3764-60500	Packaging Kit, 8-bin Mailbox	Table 8-1 (page 677)
C3764-60505	Face-up Bin (8-bin Mailbox)	Table 8-14 (page 707)
C3764-60507	Delivery Head Position Motor	Table 8-16 (page 711)
C3764-60555	Top Cover, 8-bin Mailbox	Table 8-14 (page 707)
C3764-60561	Input Paper Guide (Nose Piece)	Table 8-16 (page 711)
C3765-60500	Packaging Kit, Envelope Feeder	Table 8-1 (page 677)
C3765-60501	Envelope Feeder/C4242A	Table 8-1 (page 677)
C3766-60501	Top Cover Assembly, stapler	Table 8-17 (page 713)
C3766-60503	Stapling Bed Assembly	Table 8-17 (page 713)
C3766-60505	Back Plate	Table 8-17 (page 713)
C3766-60506	Hinges, Set of	Table 8-17 (page 713)
C3766-60507	Wire Frame	Table 8-17 (page 713)
C3766-60508	Brushes	Table 8-17 (page 713)
C3766-60509	Stapler Packaging	Table 8-17 (page 713)
C3766-60510	Kit: Plastic staple cover; scan bar bin full sensor, actuator, and flag	Table 8-17 (page 713)
C3766-60511	Kit: T10 Torx screws (10)	Table 8-17 (page 713)
C3766-60512	C-link Cable (97 cm)	Table 8-17 (page 713)
C3766-60539	C-link Cable Assembly 97 cm (8-bin Mailbox to Stapler)	Table 8-1 (page 677) Table 8-15 (page 709)
C3766-60516	Mailbox with Stapler Packaging	Table 8-17 (page 713)

Table 8-19. Numerical Parts List (continued)

Part Number	Description	Table No. and Page
C3914-69001 (ex.)	Maintenance Kit, 100-120V/C3914A	Table 8-1 (page 677)
C3915-69001 (ex.)	Maintenance Kit, 220-240V/C3915A	Table 8-1 (page 677)
C4107-67901	Formatter Assembly	Table 8-1 (page 677)
C4107-69001 (ex.)	Formatter Assembly, Exchange	Table 8-1 (page 677)
C4214-40029	Overlay, Control Panel (English)	Table 8-2 (page 681)
C4214-40030	Overlay, Control Panel (French)	Table 8-2 (page 681)
C4214-40031	Overlay, Control Panel (Italian)	Table 8-2 (page 681)
C4214-40032	Overlay, Control Panel (Portuguese)	Table 8-2 (page 681)
C4214-40041	Overlay, Control Panel (German)	Table 8-2 (page 681)
C4214-40042	Overlay, Control Panel (Spanish)	Table 8-2 (page 681)
C4214-69001 (ex.)	Assembly, DC Controller PCB (exchange)	Table 8-8 (page 692)
C4214-69003 (ex.)	Assembly, Laser Scanner (exchange)	Table 8-5 (page 687)
C4214-69004 (ex.)	Paper Input Unit (PIU) (exchange)	Table 8-3 (page 683)
C4214-69007 (ex.)	Fusing Assembly, 110V (exchange)	Table 8-3 (page 683)
C4214-69008 (ex.)	Fusing Assembly, 220V (exchange)	Table 8-3 (page 683)
C4781-60500	Power Box (Includes bracket clip)	Table 8-1 (page 677) Table 8-11 (page 697) Table 8-12 (page 699)
C4781-60501	Jumper Cable, Short	Table 8-1 (page 677) Table 8-11 (page 697) Table 8-12 (page 699)
C4781-60502	Jumper Cable, Long	Table 8-1 (page 677) Table 8-11 (page 697) Table 8-12 (page 699)
C4782-60501 C4782-69501 (ex.)	Duplexer/C4782A	Table 8-1 (page 677)
C4783-70000	C-link Cable (80 cm)	Table 8-13 (page 703)
C4784-60500	Stand for 7-bin Tabletop Mailbox/C4239A	Table 8-1 (page 677) Table 8-13 (page 703)
C4785-60500	8-bin Mailbox Assembly with attachment rod (Whole Unit)	Table 8-1 (page 677) Table 8-14 (page 707)
C4785-60501	Power Supply (8-bin Mailbox)	Table 8-16 (page 711)
C4785-60502	Standard Output Bin	Table 8-14 (page 707)
C4785-60503	Blind Cover	Table 8-14 (page 707)
C4785-60504	Front Cover, 8-bin Mailbox	Table 8-14 (page 707)
C4785-60505	Back Cover, 8-bin Mailbox	Table 8-16 (page 711)

Table 8-19. Numerical Parts List (continued)

Part Number	Description	Table No. and Page
C4785-60506	Head Assembly (with Metal Tape)	Table 8-15 (page 709)
C4785-60507	Metal Tape and Housing Assembly	Table 8-15 (page 709)
C4785-60508	8-bin Mailbox Controller (with metal box)	Table 8-14 (page 707)
C4785-60509	Flipper Assembly	Table 8-15 (page 709)
C4785-60510	Nonadjustable Fixed Caster	Table 8-14 (page 707)
C4785-60511	Adjustable Fixed Caster	Table 8-14 (page 707)
C4785-60512	Attachment Clip	Table 8-16 (page 711)
C4785-60513	Repackaging Kit	Table 8-15 (page 709)
C4785-60514	3 Diagnostic LED PCA (with Cable)	Table 8-16 (page 711)
C4785-60515	User LED PCA (with Cable)	Table 8-14 (page 707)
C4785-60516	Attachment Assembly (Rod, Bracket, Cables)	Table 8-14 (page 707)
C4785-60518	Transport Belt Motor (with Fan)	Table 8-16 (page 711)
C4785-60519	Plastic Parts	Table 8-14 (page 707) Table 8-15 (page 709) Table 8-16 (page 711)
C4785-60520	Cables	Table 8-16 (page 711)
C4785-60521	Hardware	Table 8-14 (page 707) Table 8-15 (page 709) Table 8-16 (page 711)
C4785-69500 (ex.)	8-bin Mailbox Assembly without attachment rod (Exchange Unit)	Table 8-14 (page 707)
C4785-70001	Short C-link Cable adapter	Table 8-15 (page 709)
C4787-60500	Stapler Assembly	Table 8-1 (page 677) Table 8-14 (page 707) Table 8-17 (page 713)
C4787-60501	Stapler Control PCA	Table 8-17 (page 713)
C4787-60502	5-bin Mailbox with Stapler/C4241A (8-bin Mailbox only, without the Stapler Unit.)	Table 8-1 (page 677) Table 8-14 (page 707)
C4787-60503	Shipping Lock Kit for 8-bin Mailbox/5-bin Mailbox with Stapler	Table 8-16 (page 711)
C4787-69500 (ex.)	Stapler Assembly (Exchange Unit)	Table 8-14 (page 707) Table 8-17 (page 713)
C4787-69502 (ex.)	5-bin Mailbox - for Stapler Assembly (Exchange Unit)	Table 8-14 (page 707)
R95-3002-000CN	2000-sheet Input Tray (Tray 4)/C4237A	Table 8-1 (page 677) Table 8-11 (page 697)
R95-3003-000CN	2 x 500-sheet Input Tray (Tray 4 and 5)/C4236A	Table 8-1 (page 677) Table 8-12 (page 699)

Table 8-19. Numerical Parts List (continued)

Part Number	Description	Table No. and Page
R95-3007-000CN	7-bin Tabletop Mailbox/C4238A	Table 8-1 (page 677) Table 8-13 (page 703)
R98-1006-000CN	Tray 5 Assembly	Table 8-12 (page 699)
R98-1007-000CN	Tray 4 Assembly	Table 8-12 (page 699)
RA2-2408-000CN	Bottom Bin (Tray)	Table 8-13 (page 703)
RA2-2439-000CN	Pin Positioning Bushing	Table 8-13 (page 703)
RA2-2455-000CN	Back Cover, 7-bin Tabletop Mailbox	Table 8-13 (page 703)
RA2-2484-000CN	Bin Full Sensor	Table 8-13 (page 703)
RA2-2485-000CN	Flag, Sensor	Table 8-13 (page 703)
RA2-2487-000CN	Reversing Tray (Face-up)	Table 8-13 (page 703)
RA2-2500-000CN	Support Plate	Table 8-13 (page 703)
RA2-2505-000CN	Bushing	Table 8-13 (page 703)
RA2-2512-000CN	Handle Latch	Table 8-13 (page 703)
RA2-2513-000CN	Spring Tension	Table 8-13 (page 703)
RA2-2527-000CN	Plate, Stopper	Table 8-13 (page 703)
RA2-2531-000CN	Cover Latch	Table 8-13 (page 703)
RA2-2541-000CN	Plate (Motor Cover)	Table 8-13 (page 703)
RA2-3842-000CN	Rail Assembly	Table 8-13 (page 703)
RB1-6409-000CN	Sensor Arm Spring	Table 8-7 (page 691)
RB1-6417-000CN	Sensor Arm PS1	Table 8-7 (page 691)
RB1-6421-000CN	Foot	Table 8-4 (page 685)
RB1-6427-000CN	Stopper, CG	Table 8-5 (page 687)
RB1-6441-000CN	Transfer Guide Bushing	Table 8-3 (page 683)
RB1-6444-000CN	Arm-Pressure-front	Table 8-4 (page 685)
RB1-6446-000CN	Release, Arm	Table 8-4 (page 685)
RB1-6461-000CN	Holder, Damper-Front	Table 8-3 (page 683)
RB1-6462-000CN	Holder, Damper-Rear	Table 8-3 (page 683)
RB1-6464-000CN	Cover, Upper Right	Table 8-4 (page 685)
RB1-6473-000CN	Shutter, White	Table 8-5 (page 687)
RB1-6480-000CN	Cover, Left-Lower	Table 8-2 (page 681)
RB1-6484-000CN	Open/Close Stopper	Table 8-2 (page 681)
RB1-6489-000CN	Electrical Cover (Rear by Formatter)	Table 8-2 (page 681)
RB1-6490-000CN	Tray, Output-Face-down	Table 8-2 (page 681)

Table 8-19. Numerical Parts List (continued)

Part Number	Description	Table No. and Page
RB1-6491-000CN	Face-up Bin (engine)	Table 8-1 (page 677) Table 8-2 (page 681)
RB1-6492-000CN	Cover, Switch	Table 8-2 (page 681)
RB1-6493-000CN	Spring, Compression	Table 8-2 (page 681)
RB1-6509-000CN	Spring, Torsion	Table 8-2 (page 681)
RB1-6557-000CN	Arm, Sensor-PS2	Table 8-7 (page 691)
RB1-6558-000CN	Spring, Sensor Arm	Table 8-7 (page 691)
RB1-6582-000CN	Plate, Guide-Upper	Table 8-7 (page 691)
RB1-6615-020CN	Fuser Lock Lever-Right	Table 8-3 (page 683)
RB1-6616-020CN	Fuser Lock Lever-Left	Table 8-3 (page 683)
RB1-6692-000CN	Paper Sensing Lever	Table 8-7 (page 691)
RB1-6693-000CN	Paper Height Lever	Table 8-7 (page 691)
RB1-6749-000CN	Cover, Internal Tray	Table 8-3 (page 683)
RB1-6771-000CN	Guides, Interface	Table 8-6 (page 689)
RB1-6775-000CN	Guide, Slide	Table 8-6 (page 689)
RB1-6776-000CN	Guide, Rail	Table 8-4 (page 685)
RB1-6777-000CN	Stopper, Rail	Table 8-4 (page 685)
RB1-6778-000CN	ROD	Table 8-4 (page 685)
RB1-6783-000CN	Stopper, Rail	Table 8-4 (page 685)
RB1-6894-000CN	Tray Size Plate	Table 8-10 (page 695) Table 8-12 (page 699)
RB1-7677-000CN	Metallic Retaining Tab (Plate Stop)	Table 8-11 (page 697)
RB1-7746-000CN	Tray Shipping Lock	Table 8-11 (page 697)
RB1-7832-020CN	Right Cover, 2000-sheet Input Tray	Table 8-10 (page 695)
RB1-7835-000CN	Metal retaining spring (Spring Leaf)	Table 8-11 (page 697)
RB1-9526-000CN	Multi-Purpose Tray Feed Roller	Table 8-7 (page 691)
RB2-2509-000CN	Clutch cover for 2000-sheet input tray	Table 8-11 (page 697)
RB2-2519-000CN	Back Cover, 2000-sheet Input Tray	Table 8-10 (page 695)
RB2-3503-000CN	Block, Shaft Holding, Front	Table 8-7 (page 691)
RB2-3504-000CN	Block, Shaft Holding, Rear	Table 8-7 (page 691)
RB2-3558-000CN	Delivery Cover (Left Side F/U)	Table 8-2 (page 681)
RB2-3581-000CN	Limiters, torque	Table 8-7 (page 691)
RB2-3622-000CN	Guide, Front	Table 8-4 (page 685)
RB2-3626-000CN	Front Cover (Duplex Jam Removal)	Table 8-2 (page 681)

Table 8-19. Numerical Parts List (continued)

Part Number	Description	Table No. and Page
RB2-3631-000CN	Clutch Cover	Table 8-3 (page 683)
RB2-3641-000CN	Hinge Plate	Table 8-2 (page 681)
RB2-3642-000CN	Right, Lower Cover (Rear Plastic on Sheet Metal)	Table 8-2 (page 681)
RB2-3666-000CN	Right Cover, 2 x 500-sheet Input Tray	Table 8-12 (page 699)
RB2-3667-000CN	Holder Size PCA	Table 8-12 (page 699)
RB2-3668-000CN	Front Door (Cover Storage Tray)	Table 8-12 (page 699)
RB2-3669-000CN	Storage Paper Tray	Table 8-12 (page 699)
RB2-3675-000CN	Back Cover, 2 x 500-sheet Input Tray	Table 8-12 (page 699)
RB2-3690-000CN	Clutch cover for 2 x 500-sheet input tray	Table 8-12 (page 699)
RB2-3705-000CN	Spacer, latch	Table 8-12 (page 699)
RB5-1845-000CN	PCB, Tray Sensor	Table 8-8 (page 692)
RF1-4004-000CN	Front Cover, 7-bin Tabletop Mailbox	Table 8-13 (page 703)
RF1-4005-000CN	Latching Mechanism	Table 8-13 (page 703)
RF5-1402-000CN	Cover, Rear	Table 8-2 (page 681)
RF5-1464-000CN	Shield, Plate	Table 8-6 (page 689)
RF5-1484-000CN	Paper Size Guide (Trays 2 and 3)	Table 8-1 (page 677)
RF5-1834-000CN	Feed and Separation Rollers	Table 8-10 (page 695) Table 8-12 (page 699)
RF5-1835-000CN	Pickup Roller, 2000-sheet Input Tray	Table 8-10 (page 695)
RF5-2556-000CN	Locating Pin, Metal (Positioning)	Table 8-10 (page 695) Table 8-12 (page 699)
RF5-2568-000CN	Front Cover (with LED window)	Table 8-10 (page 695)
RF5-2646-000CN	Left Cover, 2000-sheet Input Tray	Table 8-10 (page 695)
RF5-2675-000CN	Roller, Transfer	Table 8-3 (page 683)
RF5-2676-000CN	Transfer Guide	Table 8-3 (page 683)
RF5-2678-000CN	Shield, Formatter	Table 8-6 (page 689)
RF5-2701-000CN	Hinge, Stopper	Table 8-2 (page 681)
RF5-2703-000CN	MP Separation Pad	Table 8-7 (page 691)
RF5-2708-000CN	Roller, Pickup	Table 8-7 (page 691) Table 8-12 (page 699)
RF5-2726-000CN	Guide, Rear	Table 8-4 (page 685)
RF5-2762-000CN	Front Top Cover	Table 8-12 (page 699)
RF5-2764-000CN	Left Cover, 2 x 500-sheet Input Tray	Table 8-12 (page 699)

Table 8-19. Numerical Parts List (continued)

Part Number	Description	Table No. and Page
RF5-2766-000CN	Top Cover (Includes label), 2 x 500-sheet Input Tray	Table 8-12 (page 699)
RF7-1395-000CN	Reversing Mechanism Motor	Table 8-13 (page 703)
RF9-1249-000CN	Top Cover Assembly	Table 8-2 (page 681)
RG1-3814-000CN	Full Bin and Interlock sensor PCA	Table 8-13 (page 703)
RG1-3815-000CN	Empty Bin Sensor PCA	Table 8-13 (page 703)
RG1-3816-000CN	Face-up Bin Full and Sensor PCA	Table 8-13 (page 703)
RG1-3817-000CN	LED PCA	Table 8-13 (page 703)
RG1-3836-000CN	Face-down Bin Assembly, Odd (with 1 roller)	Table 8-13 (page 703)
RG1-3837-000CN	Face-down Bin Assembly, Even (with 2 rollers)	Table 8-13 (page 703)
RG1-3838-000CN	Top Cover Assembly (Upper Guide), 7-bin Tabletop Mailbox	Table 8-13 (page 703)
RG1-3840-000CN	Right Cover Assembly, 7-bin Tabletop Mailbox	Table 8-13 (page 703)
RG1-3844-000CN	Diverter Assembly (Flipper)	Table 8-13 (page 703)
RG1-3853-000CN	7-bin Tabletop Mailbox Controller PCA Assembly	Table 8-13 (page 703)
RG5-1843-000CN	Sensor Cable	Table 8-7 (page 691)
RG5-1845-000CN	Tray-Size Sensing PCA	Table 8-12 (page 699)
RG5-1846-000CN	PCB, Switch/Sensor	Table 8-8 (page 692)
RG5-1850-000CN	Cable, Fuser 2	Table 8-6 (page 689)
RG5-1859-000CN	Cable, Sensor	Table 8-7 (page 691)
RG5-1860-000CN	PCA, PIU	Table 8-7 (page 691)
RG5-1861-000CN	Cable, Paper Pickup	Table 8-7 (page 691)
RG5-1874-000CN	Face-down Delivery Assembly	Table 8-3 (page 683) Table 8-7 (page 691)
RG5-1875-000CN	Face-up Solenoid Assembly	Table 8-9 (page 693)
RG5-1884-000CN	PCB, Tray, Multi-purpose	Table 8-8 (page 692)
RG5-1915-000CN	Right Cover Assembly, engine	Table 8-2 (page 681)
RG5-1920-000CN	Cable, Tray Sensor	Table 8-4 (page 685)
RG5-1921-000CN	Cable, Fan 1	Table 8-6 (page 689)
RG5-1928-000CN	Cable, Registration	Table 8-6 (page 689)
RG5-2166-000CN	Paper Quantity Sensor PCA Assembly	Table 8-11 (page 697)
RG5-2168-000CN	Paper Size Sensor PCA Assembly	Table 8-11 (page 697)
RG5-2644-000CN	Top Cover (Label Included), 2000-sheet Input Tray	Table 8-10 (page 695)
RG5-3843-000CN	Paper Pickup Assembly, 2000-sheet Input Tray	Table 8-10 (page 695)

Table 8-19. Numerical Parts List (continued)

Part Number	Description	Table No. and Page
RG5-3845-000CN	2000-sheet Input Tray Paper Tray	Table 8-10 (page 695)
RG5-3849-000CN	Plate Paper Limit Middle	Table 8-10 (page 695)
RG5-3850-000CN	Plate Paper Reference Front	Table 8-10 (page 695)
RG5-3851-000CN	Paper Deck Drive Assembly, 2000-sheet Input Tray	Table 8-10 (page 695)
RG5-3852-000CN	Outrigger, 2 x 500-sheet Input Tray	Table 8-12 (page 699)
RG5-3853-000CN	Feet Adjustable Tip	Table 8-11 (page 697) Table 8-12 (page 699)
RG5-3854-000CN	Vertical Transfer Unit (VTU)	Table 8-10 (page 695)
RG5-3908-000CN	Paper Deck PCA (2000-sheet Input Tray Controller)	Table 8-11 (page 697)
RG5-3909-000CN	Power Supply Cable (PSU)	Table 8-11 (page 697) Table 8-12 (page 699)
RG5-3919-000CN	Main Cable, 2000-sheet Input Tray	Table 8-11 (page 697)
RG5-3951-000CN	Tray 2	Table 8-1 (page 677)
RG5-3952-000CN	Tray 3	Table 8-1 (page 677)
RG5-4021-000CN	Universal Power Supply Assembly	Table 8-11 (page 697) Table 8-12 (page 699)
RG5-4201-000CN	Plate Paper Limit Back	Table 8-10 (page 695)
RG5-4204-000CN	Front LED PCA with holder and cable	Table 8-11 (page 697)
RG5-4205-000CN	Outrigger, 2000-sheet Input Tray	Table 8-11 (page 697)
RG5-4300-000CN	Power Supply, Low-Voltage 110 V	Table 8-6 (page 689)
RG5-4301-000CN	Power Supply, Low Voltage-220 V	Table 8-6 (page 689)
RG5-4303-000CN	Registration Assembly	Table 8-3 (page 683)
RG5-4304-000CN	Assembly, Transfer Roller	Table 8-3 (page 683)
RG5-4305-000CN	Feeder Assembly	Table 8-3 (page 683) Table 8-7 (page 691)
RG5-4306-000CN	High-Voltage Power Supply	Table 8-5 (page 687)
RG5-4315-000CN	Fusing Assembly, 110V	Table 8-3 (page 683)
RG5-4317-000CN	Fusing Assembly, 220V	Table 8-3 (page 683)
RG5-4325-000CN	Diverter Assembly	Table 8-2 (page 681)
RG5-4329-000CN	MP Tray Assembly Cover (Tray 1)	Table 8-3 (page 683)
RG5-4330-000CN	Multi-purpose Tray Assembly (Tray 1)	Table 8-3 (page 683) Table 8-7 (page 691)
RG5-4334-000CN	Assembly, Paper Pickup	Table 8-7 (page 691)
RG5-4344-000CN	Assembly, Laser Scanner	Table 8-5 (page 687)

Table 8-19. Numerical Parts List (continued)

Part Number	Description	Table No. and Page
RG5-4360-000CN	Top Cover Assembly	Table 8-2 (page 681)
RG5-4362-000CN	Front Cover, engine	Table 8-2 (page 681)
RG5-4365-000CN	Printer Drive Assembly	Table 8-3 (page 683)
RG5-4375-000CN	Assembly, DC Controller PCB	Table 8-8 (page 692)
RG5-4377-000CN	Laser and Control Panel Cable	Table 8-5 (page 687)
RG5-4378-000CN	Cable, Scanner Motor	Table 8-5 (page 687)
RG5-4381-000CN	Cable, Fuser 1	Table 8-6 (page 689)
RG5-4384-000CN	Display, Control Panel	Table 8-2 (page 681)
RG5-4386-000CN	Main Motor Cable	Table 8-3 (page 683)
RG5-4403-000CN	Paper Feed Assembly (Vertical Transfer Unit)	Table 8-12 (page 699)
RG5-4410-000CN	Paper Pickup Assembly, 2 x 500-sheet Input Tray	Table 8-12 (page 699)
RG5-4416-000CN	Paper Deck Drive Assembly, 2 x 500-sheet Input Tray	Table 8-12 (page 699)
RG5-4434-000CN	Paper Input Unit (PIU)	Table 8-3 (page 683)
RG5-4440-000CN	Main Cable, 2 x 500-sheet Input Tray	Table 8-12 (page 699)
RG5-4441-000CN	Front LED PCA	Table 8-12 (page 699)
RG5-4442-000CN	2 x 500-sheet Input Tray Controller PCA	Table 8-12 (page 699)
RH3-2205-000CN	Power Supply (7-bin Tabletop Mailbox)	Table 8-13 (page 703)
RH7-1266-000CN	Fan, FM2/Laser Scanner	Table 8-5 (page 687)
RH7-1271-000CN	Fan, FM3/Formatter	Table 8-6 (page 689)
RH7-1289-000CN	Fan, FM4/Delivery Assembly	Table 8-7 (page 691)
RH7-1350-000CN	Motor, PIU	Table 8-7 (page 691)
RH7-1396-000CN	Fan, FM1/Low Voltage Power Supply	Table 8-6 (page 689)
RH7-1397-000CN	Fan, FM5	Table 8-7 (page 691)
RH7-5187-000CN	Electromagnetic Clutch	Table 8-3 (page 683)
RH7-5188-000CN	Clutch, Paper Feed	Table 8-7 (page 691)
RH7-5219-000CN	Main Motor	Table 8-3 (page 683)
RH7-5223-000CN	Solenoid Reversing Mechanism	Table 8-13 (page 703)
RH7-5225-000CN	Solenoid Flipper	Table 8-13 (page 703)
RS5-1127-000CN	Gear, 20T	Table 8-2 (page 681)
RS5-1399-000CN	Paper Deck Drive Bushing	Table 8-10 (page 695)
RS5-2499-000CN	Spring, Tension	Table 8-4 (page 685)
RS5-2561-000CN	Tension Spring	Table 8-11 (page 697)

Table 8-19. Numerical Parts List (continued)

Part Number	Description	Table No. and Page
RS5-8605-000CN	Paper Size Guide Label (Trays 2 and 3)	Table 8-1 (page 677)
RS5-8611-000CN	Tray Size Labels	Table 8-10 (page 695) Table 8-12 (page 699)
RS5-8676-000CN	Label, Operation	Table 8-2 (page 681)
RS6-2072-000CN	Compression Spring, Front	Table 8-7 (page 691)
RS6-2073-000CN	Compression Spring, Rear	Table 8-7 (page 691)
RY7-5044-000CN	2K (2000-sheet Input Tray) Deck Hardware Kit	Table 8-10 (page 695) Table 8-11 (page 697)
RY7-5048-000CN	Hardware Screws Kit for 7-bin Tabletop Mailbox	Table 8-13 (page 703)
VD7-1893-151CN	Power Supply Fuse 250V/3.15A	Table 8-11 (page 697) Table 8-12 (page 699)
WG8-0291-000CN	Photo Interrupter	Table 8-7 (page 691)
XA9-0605-000CN	Screw, M4 x 8	Table 8-2 (page 681)
XA9-0870-000CN	Screw, M4 x 10	Table 8-2 (page 681)
XA9-0872-000CN	Screw, M3 x 8	Table 8-2 (page 681)
XB6-7400-807CN	Screw, M4 x 8 TP	Table 8-3 (page 683)
XZ9-0379-000CN	Latch	Table 8-12 (page 699)
XZ9-0442-000CN	Caster	Table 8-10 (page 695) Table 8-12 (page 699)

HP Digital Copy 320 Parts and Diagrams

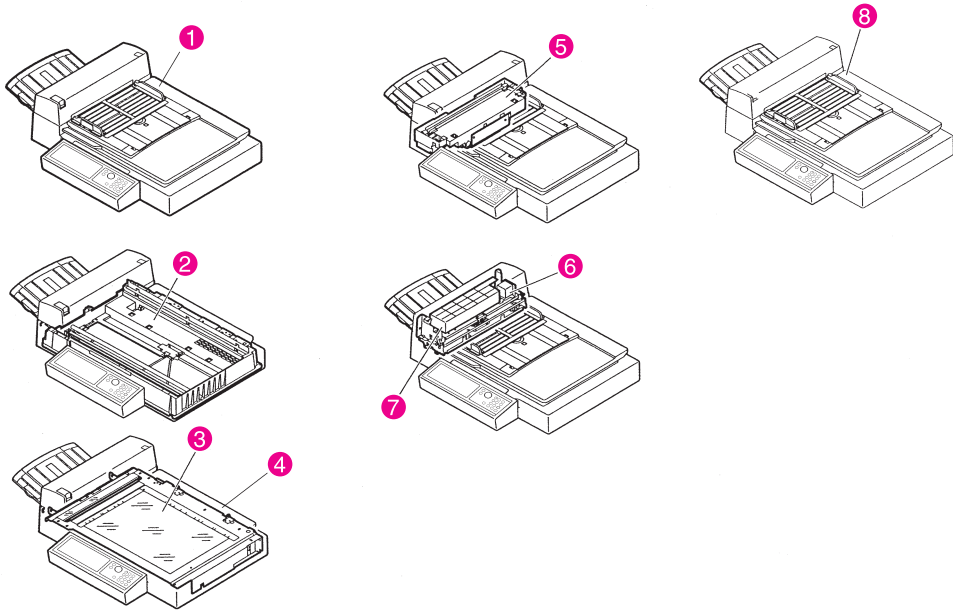

Figure 8-18 Assembly Location Diagram

- 1 Covers
- 2 Flatbed
- 3 Glass Plate Assembly
- 4 Power Supply and Main Board Tray
- 5 Carrier Unit
- 6 ADF Unit
- 7 Optical Unit
- 8 Document Cover Assembly

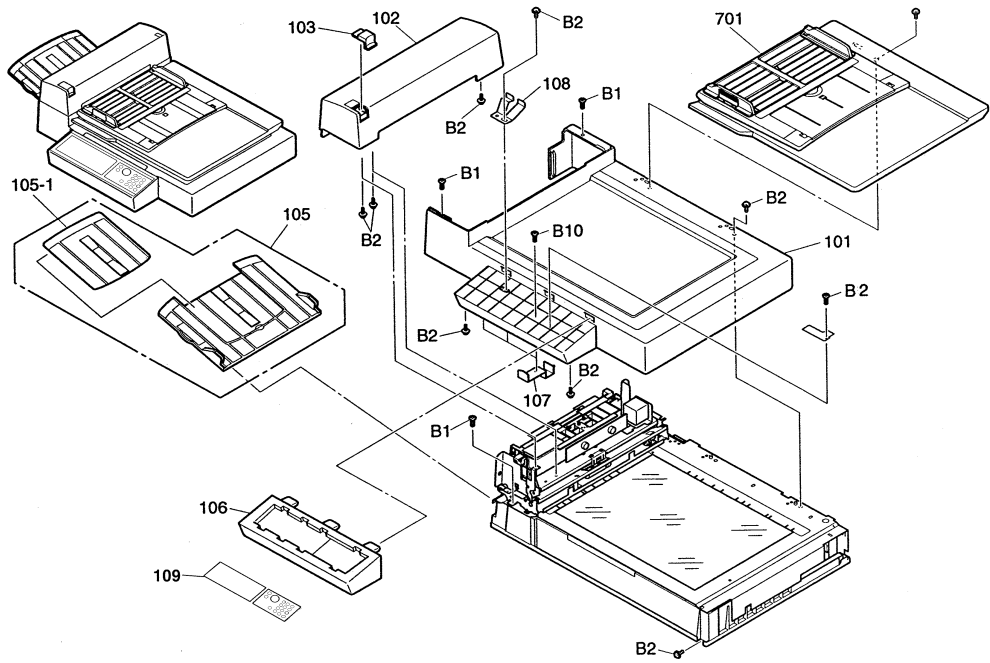

Figure 8-19 Covers

Table 8-20. Covers

Ref	Description	Part Number	QTY
101	Upper Cover (skin)	PA03002-C107FJ	1
102	ADF Cover (skin)	PA03002-C106FJ	1
103	ADF Latch Cap	PA03002-C201FJ	1
105	Output Tray Assembly	PA03002-C121FJ	1
105-1	Output Tray Flip-out	PA03002-C263FJ	1
106	Panel Cover	PA03002-C264FJ	1
107	Front Panel Bracket	PA03002-C257FJ	3
108	Front Panel Frame Ground Spring	PA03002-C266FJ	1
109	Front Panel	9000288TF	1
not shown	Front Panel Frame Ground Plate	PA03002-C272FJ	1
not shown	Front Panel Cable Clamp	PA03002-C273FJ	1

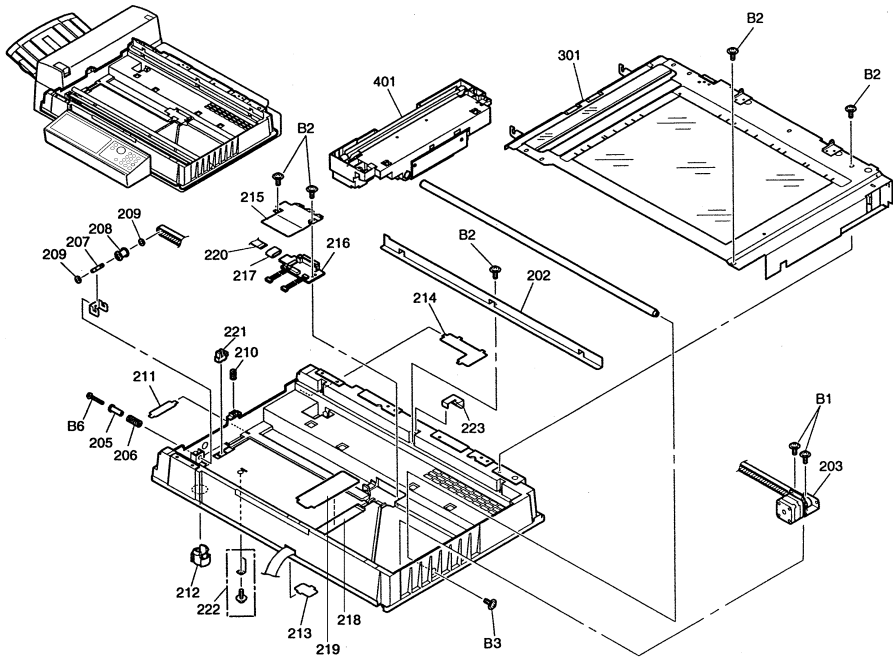

Figure 8-20 Flatbed

Table 8-21. Flatbed

Ref	Description	Part Number	QTY
202	Carrier Rail	PA03002-C205FJ	1
203	FB Motor Unit (w/belt)	PA03002-C116FJ	1
205	Carrier Tension Pulley Collar	PA03002-C214FJ	1
206	Carrier Tension Pulley Spring	PA03002-C212FJ	1
207	Carrier Tension Pulley Shaft	PA03002-C211FJ	1
208	Carrier Belt Tension Pulley	PA03002-C210FJ	1
209	Carrier Tension Pulley Spacer	PA03002-C213FJ	2
210	Idle Roller Coil Spring	PA03002-C209FJ	1
211	Carrier Unit Protector	PA03002-C216FJ	1
212	Rubber Foot	PA03002-C218FJ	4
213	Carrier Ribbon Cable Protector	PA03002-C217FJ	1
214	Control PCA Protector	PA03002-C215FJ	1
215	Junction PCA Cover	PA03002-C267FJ	1

Table 8-21. Flatbed (continued)

Ref	Description	Part Number	QTY
216	Junction PCA	PA03002-C103FJ	1
217	Carrier Ribbon Cable Ferrite Bead	PA03002-C262FJ	1
218	Front Panel Cable	PA03002-C125FJ	1
219	Front Panel Cable Cover	PA03002-C270FJ	1
220	Carrier Flex Cable	PA03002-C204FJ	1
221	Home Position Sensor	PA03002-C207FJ	1
222	Carrier Stopper (shipping lock)	PA03002-C124FJ	1
223	Frame Ground Spring 1	PA03002-C208FJ	1

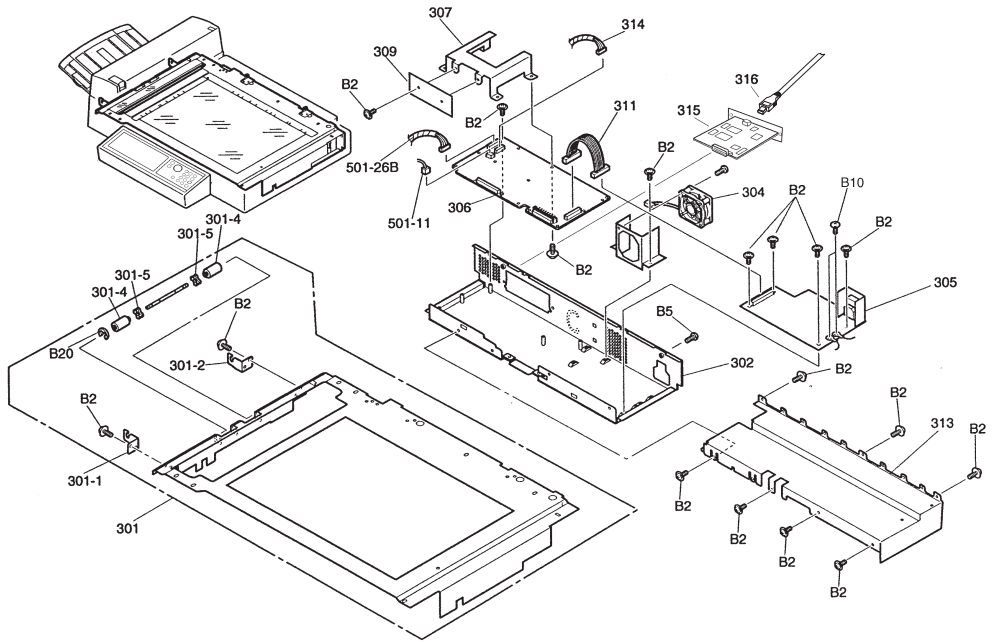

Figure 8-21 Glass Plate and PCA Assembly

Table 8-22. Glass Plate and PCA Assembly

Ref	Description	Part Number	QTY
301	Glass Plate Assembly	PA03002-C219FJ	1
301-1	Output Tray Bracket, Front	PA03002-C223FJ	1
301-2	Output Tray Bracket, Rear	PA03002-C222FJ	1
301-4	Exit Idle Roller	PA03002-C224FJ	2
301-5	HK Ring V2	PA03002-C225FJ	2
302	Main/PS Cover Bracket	PA03002-C220FJ	1
304	Fan Assembly	PA03002-C118FJ	1
305	Power Supply	PA03002-C101FJ	1
306	Control PCA (FJ)	PA03002-C102FJ	1
307	Copy Processor Card Cage	PA03002-C258FJ	1
309	Back PCA Board (CP mate)	PA03002-C119FJ	1
311	DC Cable PS to Main	PA03002-C203FJ	1
313	RFI Cover	PA03002-C202FJ	1
314	CCD Cable	PA03002-C229FJ	1

Table 8-22. Glass Plate and PCA Assembly (continued)

Ref	Description	Part Number	QTY
315	Copy Processor Card	PM-3700	1
316	Copy Connect Cable	8120-8749	1

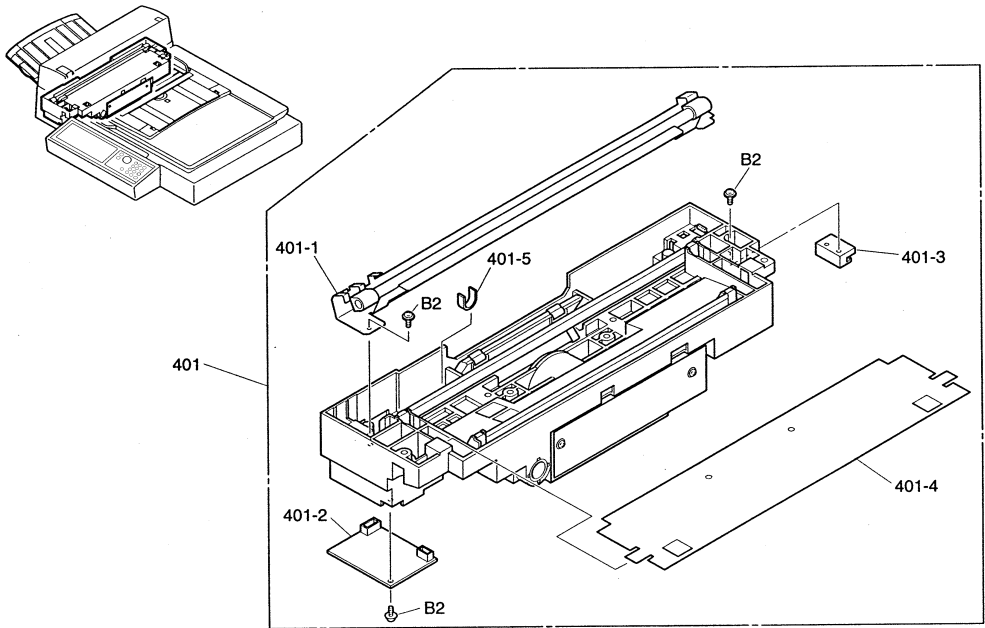

Figure 8-22 Carrier Unit

Table 8-23. Carrier Unit

Ref	Description	Part Number	QTY
401	Carrier Unit	PA03002-C113FJ	1
401-1	Lower Lamp (front side)	PA03002-C114FJ	1
401-2	Carrier Unit Lamp PCA	PA03002-C251FJ	1
401-3	Carrier Rail Bushing	PA03002-C206FJ	1
401-4	Carrier Unit Dust Cover	PA03002-C256FJ	1
401-5	Carrier Unit Lubrication Felt	PA03002-C259FJ	1

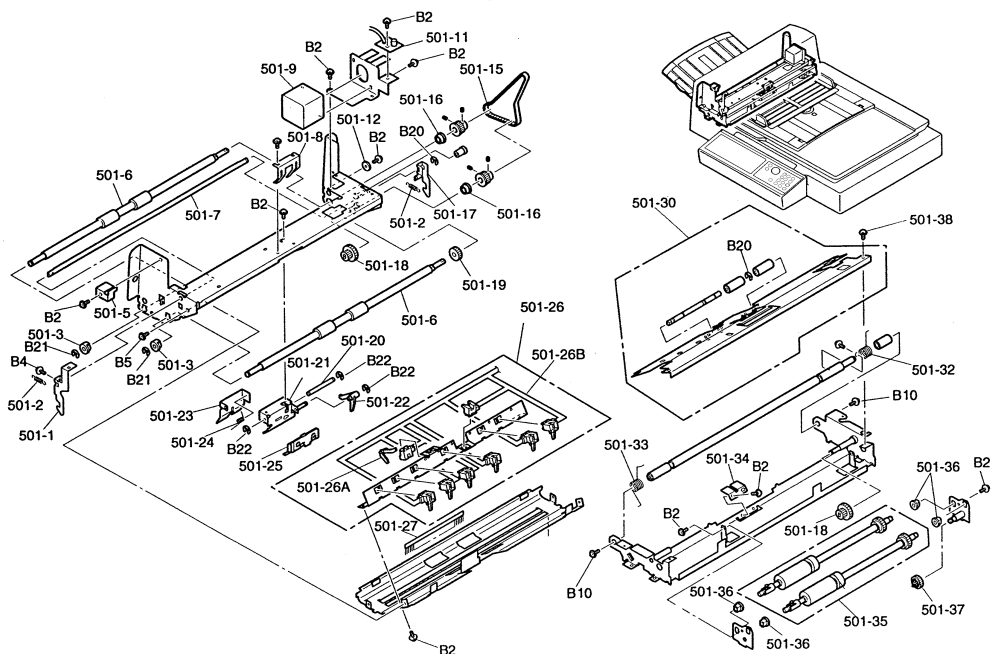

Figure 8-23 ADF Unit

Table 8-24. ADF Unit

Ref	Description	Part Number	QTY
501-1	ADF Latch Lever Front	PA03002-C242FJ	1
501-2	ADF Latch Spring	PA03002-C245FJ	2
501-3	Drive Roller Bearing	PA03002-C233FJ	2
501-5	Optical Unit Tie Down w/Pad	PA03002-C227FJ	1
501-6	Drive Roller Shaft	PA03002-C230FJ	2
501-7	ADF Latch Shaft	PA03002-C244FJ	1
501-8	Pick Spring	PA03002-C240FJ	1
501-9	ADF Motor Unit	PA03002-C109FJ	1
501-11	LED Assembly (includes cable)	PA03002-C126FJ	1
501-12	Key Washer	PA03002-C241FJ	1
501-15	ADF Belt	PA03002-C111FJ	1
501-16	Bearing for Feed Roller	PA03002-C265FJ	2
501-17	ADF Latch Lever Rear	PA03002-C243FJ	1

Table 8-24. ADF Unit (continued)

Ref	Description	Part Number	QTY
501-18	Reduction Gear	PA03002-C232FJ	2
501-19	Drive Roller Gear	PA03002-C231FJ	1
501-20	Pad Shaft	PA03002-C238FJ	2
501-21	Pad Assembly Frame	PA03002-C236FJ	1
501-22	ADF Paper Empty Sensor Arm	PA03002-C235FJ	1
501-23	Pad Plate	PA03002-C239FJ	1
501-24	Pad Spring	PA03002-C237FJ	1
501-25	Separation Pad Assembly	PA03002-C122FJ	1
501-26	Sensor Unit Assembly	PA03002-C110FJ	1
501-26A	Top of Form Sensor Arm	PA03002-C234FJ	1
501-26B	ADF Cable	PA03002-C228FJ	1
501-27	Paper Anti Static Assembly	PA03002-C246FJ	1
501-30	Pick Roller Cover	PA03002-C112FJ	1
501-32	ADF Lift Spring Rear	PA03002-C248FJ	1
501-33	ADF Lift Spring Front	PA03002-C247FJ	1
501-34	Idle Roller Leaf Spring	PA03002-C249FJ	1
501-35	Pick Roller Assembly	PA03002-C120FJ	1
501-36	Brass Bushing for Pick Roller	PA03002-C269FJ	4
501-37	Pick Roller Clutch/Gear	PA03002-C250FJ	1
501-38	Thumb Screws (paper guide) (screws for Pick Roller Cover)	PA03002-C123FJ	2

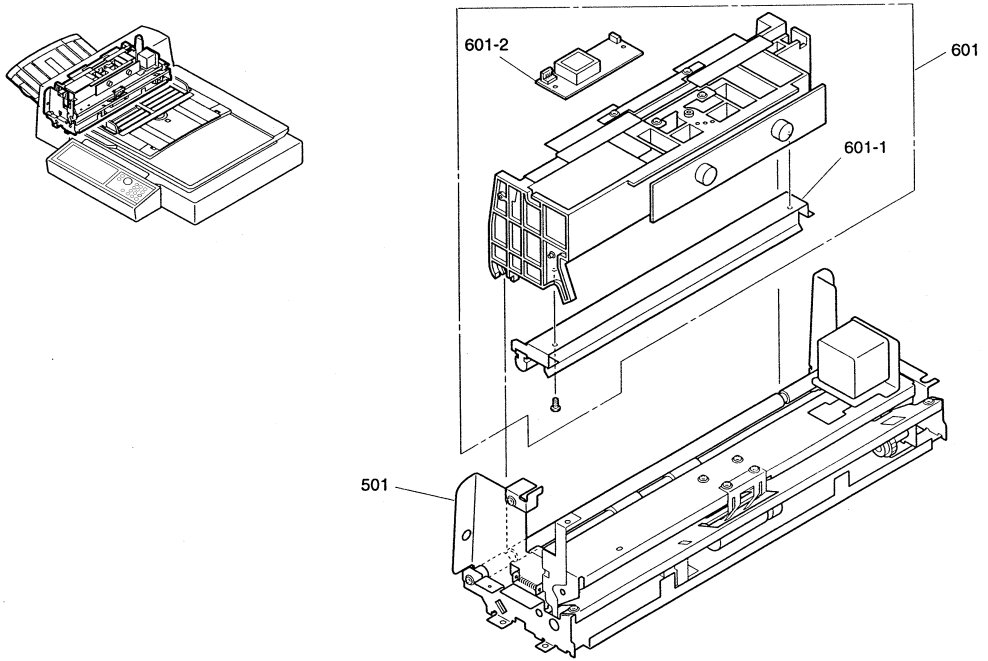

Figure 8-24 Optical Unit

Table 8-25. Optical Unit

Ref	Description	Part Number	QTY
501	ADF Unit	PA03002-C108FJ	1
601	Optical Unit	PA03002-C117FJ	1
601-1	Upper Lamp (back side)	PA03002-C115FJ	1
601-2	ADF Lamp PCA	PA03002-C252FJ	1

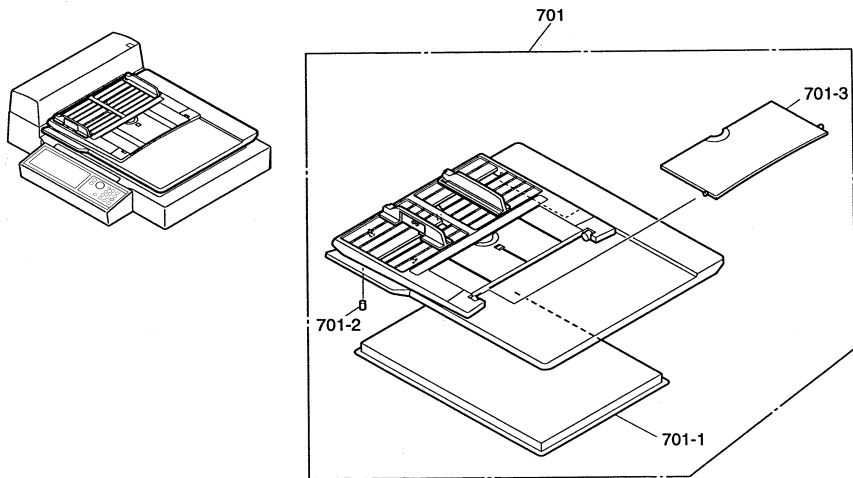

Figure 8-25 Document Cover Assembly

Table 8-26. Document Cover Assembly

Ref	Description	Part Number	QTY
701	FB Cover Assembly	PA03002-C104FJ	1
701-1	Document Holding Pad	PA03002-C105FJ	1
701-2	Rubber Stop, Document Cover	PA03002-C226FJ	1
701-3	Paper Chute Flip Out	PA03002-C260FJ	1

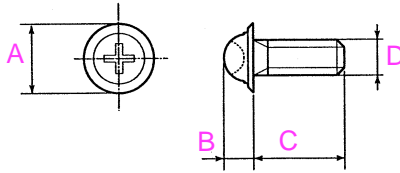

Figure 8-26 Screws (1 of 4)

Table 8-27. Screws (1 of 4)

Ref	A	B	C	D	Description	Part Number	Qty in kit
B1	8 mm	2.5 mm	8 mm	3 mm	TP Screw m3 x 8	PA03002-C282FJ	20
B2	8 mm	2.5 mm	6 mm	3 mm	TP Screw m3 x 6	PA03002-C281FJ	20

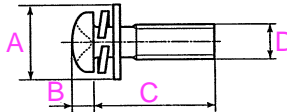

Figure 8-27 Screws (2 of 4)

Table 8-28. Screws (2 of 4)

Ref	A	B	C	D	Description	Part Number	Qty in kit
B3	10 mm	3.2 mm	8 mm	4 mm	TP Screw m4 x 8	PA03002-C288FJ	20
B4	7 mm	2 mm	6 mm	3 mm	Machine Screw w/ washer m3 x 6	PA03002-C283FJ	20
B5	7 mm	2 mm	8 mm	3 mm	Machine Screw w/ washer m3 x 8	PA03002-C284FJ	20
B6	7 mm	2 mm	35 mm	3 mm	Machine Screw w/ washer m3 x 35	PA03002-C285FJ	20
B10	9 mm	2.6 mm	8 mm	4 mm	Machine Screw w/ washer m4 x 8	PA03002-C286FJ	20

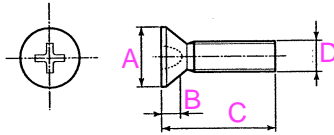

Figure 8-28 Screws (3 of 4)

Table 8-29. Screws (3 of 4)

Ref	A	B	C	D	Description	Part Number	Qty in kit
B15	6 mm	1.75 mm	6 mm	3 mm	Flat Head Screw m3 x6	PA03002-C287FJ	20

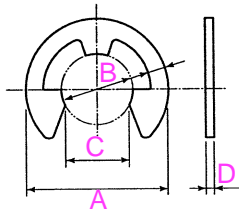

Figure 8-29 Screws (4 of 4)

Table 8-30. Screws (4 of 4)

Ref	A	B	C	D	Description	Part Number	Qty in kit
B20	7 mm	3 mm	2.6 mm	0.6 mm	E-ring, Latch Lever (20pcs)	PA03002-C254FJ	20
B21	9 mm	4 mm	3.5 mm	0.6 mm	E-ring, Idle Roller (20pcs)	PA03002-C253FJ	20
B22	5 mm	2 mm	1.7 mm	0.4 mm	Retainer Ring ADF Lock Bearing (20pcs)	PA03002-C255FJ	20
not shown					Thumb screws for Pick Roller Cover	PA03002-C123FJ	
not shown	13	5.5	10	4	Thumb screw for Document Cover	CA03002-C290	20

Alphabetical Parts List (Copy Module)

Table 8-31. Alphabetical Parts List

Description	Part Number	Table No. and Page
ADF Belt	PA03002-C111FJ	Table 8-24 (page 744)
ADF Cable	PA03002-C228FJ	Table 8-24 (page 744)
ADF Cover (skin)	PA03002-C106FJ	Table 8-20 (page 737)
ADF Lamp PCA	PA03002-C252FJ	Table 8-25 (page 746)
ADF Latch Cap	PA03002-C201FJ	Table 8-20 (page 737)
ADF Latch Lever Front	PA03002-C242FJ	Table 8-24 (page 744)
ADF Latch Lever Rear	PA03002-C243FJ	Table 8-24 (page 744)
ADF Latch Shaft	PA03002-C244FJ	Table 8-24 (page 744)
ADF Latch Spring	PA03002-C245FJ	Table 8-24 (page 744)
ADF Lift Spring Front	PA03002-C247FJ	Table 8-24 (page 744)
ADF Lift Spring Rear	PA03002-C248FJ	Table 8-24 (page 744)
ADF Motor Unit	PA03002-C109FJ	Table 8-24 (page 744)
ADF Paper Empty Sensor Arm	PA03002-C235FJ	Table 8-24 (page 744)
ADF Unit	PA03002-C108FJ	Table 8-25 (page 746)
Back PCA Board (CP mate)	PA03002-C119FJ	Table 8-22 (page 740)
Bearing for Feed Roller	PA03002-C265FJ	Table 8-24 (page 744)
Brass Bushing for Pick Roller	PA03002-C269FJ	Table 8-24 (page 744)
Calibration Target Kit	PA03002-C261FJ	
Carrier Belt Tension Pulley	PA03002-C210FJ	Table 8-21 (page 738)
Carrier Flex Cable	PA03002-C204FJ	Table 8-21 (page 738)
Carrier Rail	PA03002-C205FJ	Table 8-21 (page 738)
Carrier Rail Bushing	PA03002-C206FJ	Table 8-23 (page 743)
Carrier Ribbon Cable Ferrite Bead	PA03002-C262FJ	Table 8-21 (page 738)
Carrier Ribbon Cable Protector	PA03002-C217FJ	Table 8-21 (page 738)
Carrier Stopper (shipping lock)	PA03002-C124FJ	Table 8-21 (page 738)
Carrier Tension Pulley Collar	PA03002-C214FJ	Table 8-21 (page 738)
Carrier Tension Pulley Shaft	PA03002-C211FJ	Table 8-21 (page 738)
Carrier Tension Pulley Spacer	PA03002-C213FJ	Table 8-21 (page 738)
Carrier Tension Pulley Spring	PA03002-C212FJ	Table 8-21 (page 738)

Table 8-31. Alphabetical Parts List (continued)

Description	Part Number	Table No. and Page
Carrier Unit	PA03002-C113FJ	Table 8-23 (page 743)
Carrier Unit Dust Cover	PA03002-C256FJ	Table 8-23 (page 743)
Carrier Unit Lamp PCA	PA03002-C251FJ	Table 8-23 (page 743)
Carrier Unit Lubrication Felt	PA03002-C259FJ	Table 8-23 (page 743)
Carrier Unit Protector	PA03002-C216FJ	Table 8-21 (page 738)
CCD Cable	PA03002-C229FJ	Table 8-22 (page 740)
Control PCA (FJ)	PA03002-C102FJ	Table 8-22 (page 740)
Control PCA Protector	PA03002-C215FJ	Table 8-21 (page 738)
Copy Connect Cable	8120-8749	Table 8-22 (page 740)
Copy Processor Card	PM-3700	Table 8-22 (page 740)
Copy Processor Card Cage	PA03002-C258FJ	Table 8-22 (page 740)
DC Cable PS to Main	PA03002-C203FJ	Table 8-22 (page 740)
Document Holding Pad	PA03002-C105FJ	Table 8-26 (page 747)
Drive Roller Bearing	PA03002-C233FJ	Table 8-24 (page 744)
Drive Roller Gear	PA03002-C231FJ	Table 8-24 (page 744)
Drive Roller Shaft	PA03002-C230FJ	Table 8-24 (page 744)
E-ring, Idle Roller (20pcs)	PA03002-C253FJ	Table 8-30 (page 749)
E-ring, Latch Lever (20pcs)	PA03002-C254FJ	Table 8-30 (page 749)
Exit Idle Roller	PA03002-C224FJ	Table 8-22 (page 740)
Fan Assembly	PA03002-C118FJ	Table 8-22 (page 740)
FB Cover Assembly	PA03002-C104FJ	Table 8-26 (page 747)
FB Motor Unit (w/belt)	PA03002-C116FJ	Table 8-21 (page 738)
Flat Head Screw m3 x6	PA03002-C287FJ	Table 8-29 (page 749)
Frame Ground Spring 1	PA03002-C208FJ	Table 8-21 (page 738)
Front Panel	9000288TF	Table 8-20 (page 737)
Front Panel Bracket	PA03002-C257FJ	Table 8-20 (page 737)
Front Panel Cable	PA03002-C125FJ	Table 8-21 (page 738)
Front Panel Cable Clamp	PA03002-C273FJ	Table 8-20 (page 737)
Front Panel Cable Cover	PA03002-C270FJ	Table 8-21 (page 738)
Front Panel Frame Ground Plate	PA03002-C272FJ	Table 8-20 (page 737)
Front Panel Frame Ground Spring	PA03002-C266FJ	Table 8-20 (page 737)
Glass Plate Assembly	PA03002-C219FJ	Table 8-22 (page 740)
HK Ring V2	PA03002-C225FJ	Table 8-22 (page 740)

Table 8-31. Alphabetical Parts List (continued)

Description	Part Number	Table No. and Page
Home Position Sensor	PA03002-C207FJ	Table 8-21 (page 738)
Idle Roller Coil Spring	PA03002-C209FJ	Table 8-21 (page 738)
Idle Roller Leaf Spring	PA03002-C249FJ	Table 8-24 (page 744)
Junction PCA	PA03002-C103FJ	Table 8-21 (page 738)
Junction PCA Cover	PA03002-C267FJ	Table 8-21 (page 738)
Key Washer	PA03002-C241FJ	Table 8-24 (page 744)
LED Assembly (includes cable)	PA03002-C126FJ	Table 8-24 (page 744)
Lower Lamp (front side)	PA03002-C114FJ	Table 8-23 (page 743)
Machine Screw w/washer m3 x 35	PA03002-C285FJ	Table 8-28 (page 748)
Machine Screw w/washer m3 x 6	PA03002-C283FJ	Table 8-28 (page 748)
Machine Screw w/washer m3 x 8	PA03002-C284FJ	Table 8-28 (page 748)
Machine Screw w/washer m4 x 8	PA03002-C286FJ	Table 8-28 (page 748)
Main/PS Cover Bracket	PA03002-C220FJ	Table 8-22 (page 740)
Maintenance Kit: see Pick Roller Assembly and Separation Pad Assembly		
Optical Unit	PA03002-C117FJ	Table 8-25 (page 746)
Optical Unit Tie Down w/Pad	PA03002-C227FJ	Table 8-24 (page 744)
Output Tray Assembly	PA03002-C121FJ	Table 8-20 (page 737)
Output Tray Bracket, Front	PA03002-C223FJ	Table 8-22 (page 740)
Output Tray Bracket, Rear	PA03002-C222FJ	Table 8-22 (page 740)
Output Tray Flip-out	PA03002-C263FJ	Table 8-20 (page 737)
Pad Assembly Frame	PA03002-C236FJ	Table 8-24 (page 744)
Pad Plate	PA03002-C239FJ	Table 8-24 (page 744)
Pad Shaft	PA03002-C238FJ	Table 8-24 (page 744)
Pad Spring	PA03002-C237FJ	Table 8-24 (page 744)
Panel Cover	PA03002-C264FJ	Table 8-20 (page 737)
Paper Anti Static Assembly	PA03002-C246FJ	Table 8-24 (page 744)
Paper Chute Flip Out	PA03002-C260FJ	Table 8-26 (page 747)
Pick Roller Assembly	PA03002-C120FJ	Table 8-24 (page 744)
Pick Roller Clutch/Gear	PA03002-C250FJ	Table 8-24 (page 744)
Pick Roller Cover	PA03002-C112FJ	Table 8-24 (page 744)
Pick Spring	PA03002-C240FJ	Table 8-24 (page 744)
Power Supply	PA03002-C101FJ	Table 8-22 (page 740)

Table 8-31. Alphabetical Parts List (continued)

Description	Part Number	Table No. and Page
Reduction Gear	PA03002-C232FJ	Table 8-24 (page 744)
Retainer Ring ADF Lock Bearing (20pcs)	PA03002-C255FJ	Table 8-30 (page 749)
RFI Cover	PA03002-C202FJ	Table 8-22 (page 740)
Rubber Foot	PA03002-C218FJ	Table 8-21 (page 738)
Rubber Stop, Document Cover	PA03002-C226FJ	Table 8-26 (page 747)
Sensor Unit Assembly	PA03002-C110FJ	Table 8-24 (page 744)
Separation Pad Assembly	PA03002-C122FJ	Table 8-24 (page 744)
Thumb Screws (paper guide) (screws for Pick Roller Cover)	PA03002-C123FJ	Table 8-24 (page 744)
Top of Form Sensor Arm	PA03002-C234FJ	Table 8-24 (page 744)
TP Screw m3 x 6	PA03002-C281FJ	Table 8-27 (page 748)
TP Screw m3 x 8	PA03002-C282FJ	Table 8-27 (page 748)
Upper Cover (skin)	PA03002-C107FJ	Table 8-20 (page 737)
Upper Lamp (back side)	PA03002-C115FJ	Table 8-25 (page 746)

Numerical Parts List (Copy Module)

Table 8-32. Numerical Parts List

Part Number	Description	Table No. and Page
8120-8749	Copy Connect Cable	Table 8-22 (page 740)
9000288TF	Front Panel	Table 8-20 (page 737)
PA03002-C101FJ	Power Supply	Table 8-22 (page 740)
PA03002-C102FJ	Control PCA (FJ)	Table 8-22 (page 740)
PA03002-C103FJ	Junction PCA	Table 8-21 (page 738)
PA03002-C104FJ	FB Cover Assembly	Table 8-26 (page 747)
PA03002-C105FJ	Document Holding Pad	Table 8-26 (page 747)
PA03002-C106FJ	ADF Cover (skin)	Table 8-20 (page 737)
PA03002-C107FJ	Upper Cover (skin)	Table 8-20 (page 737)
PA03002-C108FJ	ADF Unit	Table 8-25 (page 746)
PA03002-C109FJ	ADF Motor Unit	Table 8-24 (page 744)
PA03002-C110FJ	Sensor Unit Assembly	Table 8-24 (page 744)
PA03002-C111FJ	ADF Belt	Table 8-24 (page 744)
PA03002-C112FJ	Pick Roller Cover	Table 8-24 (page 744)
PA03002-C113FJ	Carrier Unit	Table 8-23 (page 743)
PA03002-C114FJ	Lower Lamp (front side)	Table 8-23 (page 743)
PA03002-C115FJ	Upper Lamp (back side)	Table 8-25 (page 746)
PA03002-C116FJ	FB Motor Unit (w/belt)	Table 8-21 (page 738)
PA03002-C117FJ	Optical Unit	Table 8-25 (page 746)
PA03002-C118FJ	Fan Assembly	Table 8-22 (page 740)
PA03002-C119FJ	Back PCA Board (CP mate)	Table 8-22 (page 740)
PA03002-C120FJ	Pick Roller Assembly	Table 8-24 (page 744)
PA03002-C121FJ	Output Tray Assembly	Table 8-20 (page 737)
PA03002-C122FJ	Separation Pad Assembly	Table 8-24 (page 744)
PA03002-C123FJ	Thumb Screws (paper guide) (screws for Pick Roller Cover)	Table 8-24 (page 744)
PA03002-C124FJ	Carrier Stopper (shipping lock)	Table 8-21 (page 738)
PA03002-C125FJ	Front Panel Cable	Table 8-21 (page 738)
PA03002-C126FJ	LED Assembly (includes cable)	Table 8-24 (page 744)
PA03002-C201FJ	ADF Latch Cap	Table 8-20 (page 737)

Table 8-32. Numerical Parts List (continued)

Part Number	Description	Table No. and Page
PA03002-C202FJ	RFI Cover	Table 8-22 (page 740)
PA03002-C203FJ	DC Cable PS to Main	Table 8-22 (page 740)
PA03002-C204FJ	Carrier Flex Cable	Table 8-21 (page 738)
PA03002-C205FJ	Carrier Rail	Table 8-21 (page 738)
PA03002-C206FJ	Carrier Rail Bushing	Table 8-23 (page 743)
PA03002-C207FJ	Home Position Sensor	Table 8-21 (page 738)
PA03002-C208FJ	Frame Ground Spring 1	Table 8-21 (page 738)
PA03002-C209FJ	Idle Roller Coil Spring	Table 8-21 (page 738)
PA03002-C210FJ	Carrier Belt Tension Pulley	Table 8-21 (page 738)
PA03002-C211FJ	Carrier Tension Pulley Shaft	Table 8-21 (page 738)
PA03002-C212FJ	Carrier Tension Pulley Spring	Table 8-21 (page 738)
PA03002-C213FJ	Carrier Tension Pulley Spacer	Table 8-21 (page 738)
PA03002-C214FJ	Carrier Tension Pulley Collar	Table 8-21 (page 738)
PA03002-C215FJ	Control PCA Protector	Table 8-21 (page 738)
PA03002-C216FJ	Carrier Unit Protector	Table 8-21 (page 738)
PA03002-C217FJ	Carrier Ribbon Cable Protector	Table 8-21 (page 738)
PA03002-C218FJ	Rubber Foot	Table 8-21 (page 738)
PA03002-C219FJ	Glass Plate Assembly	Table 8-22 (page 740)
PA03002-C220FJ	Main/PS Cover Bracket	Table 8-22 (page 740)
PA03002-C222FJ	Output Tray Bracket, Rear	Table 8-22 (page 740)
PA03002-C223FJ	Output Tray Bracket, Front	Table 8-22 (page 740)
PA03002-C224FJ	Exit Idle Roller	Table 8-22 (page 740)
PA03002-C225FJ	HK Ring V2	Table 8-22 (page 740)
PA03002-C226FJ	Rubber Stop, Document Cover	Table 8-26 (page 747)
PA03002-C227FJ	Optical Unit Tie Down w/Pad	Table 8-24 (page 744)
PA03002-C228FJ	ADF Cable	Table 8-24 (page 744)
PA03002-C229FJ	CCD Cable	Table 8-22 (page 740)
PA03002-C230FJ	Drive Roller Shaft	Table 8-24 (page 744)
PA03002-C231FJ	Drive Roller Gear	Table 8-24 (page 744)
PA03002-C232FJ	Reduction Gear	Table 8-24 (page 744)
PA03002-C233FJ	Drive Roller Bearing	Table 8-24 (page 744)
PA03002-C234FJ	Top of Form Sensor Arm	Table 8-24 (page 744)
PA03002-C235FJ	ADF Paper Empty Sensor Arm	Table 8-24 (page 744)

Table 8-32. Numerical Parts List (continued)

Part Number	Description	Table No. and Page
PA03002-C236FJ	Pad Assembly Frame	Table 8-24 (page 744)
PA03002-C237FJ	Pad Spring	Table 8-24 (page 744)
PA03002-C238FJ	Pad Shaft	Table 8-24 (page 744)
PA03002-C239FJ	Pad Plate	Table 8-24 (page 744)
PA03002-C240FJ	Pick Spring	Table 8-24 (page 744)
PA03002-C241FJ	Key Washer	Table 8-24 (page 744)
PA03002-C242FJ	ADF Latch Lever Front	Table 8-24 (page 744)
PA03002-C243FJ	ADF Latch Lever Rear	Table 8-24 (page 744)
PA03002-C244FJ	ADF Latch Shaft	Table 8-24 (page 744)
PA03002-C245FJ	ADF Latch Spring	Table 8-24 (page 744)
PA03002-C246FJ	Paper Anti Static Assembly	Table 8-24 (page 744)
PA03002-C247FJ	ADF Lift Spring Front	Table 8-24 (page 744)
PA03002-C248FJ	ADF Lift Spring Rear	Table 8-24 (page 744)
PA03002-C249FJ	Idle Roller Leaf Spring	Table 8-24 (page 744)
PA03002-C250FJ	Pick Roller Clutch/Gear	Table 8-24 (page 744)
PA03002-C251FJ	Carrier Unit Lamp PCA	Table 8-23 (page 743)
PA03002-C252FJ	ADF Lamp PCA	Table 8-25 (page 746)
PA03002-C253FJ	E-ring, Idle Roller (20pcs)	Table 8-30 (page 749)
PA03002-C254FJ	E-ring, Latch Lever (20pcs)	Table 8-30 (page 749)
PA03002-C255FJ	Retainer Ring ADF Lock Bearing (20pcs)	Table 8-30 (page 749)
PA03002-C256FJ	Carrier Unit Dust Cover	Table 8-23 (page 743)
PA03002-C257FJ	Front Panel Bracket	Table 8-20 (page 737)
PA03002-C258FJ	Copy Processor Card Cage	Table 8-22 (page 740)
PA03002-C259FJ	Carrier Unit Lubrication Felt	Table 8-23 (page 743)
PA03002-C260FJ	Paper Chute Flip Out	Table 8-26 (page 747)
PA03002-C261FJ	Calibration Target Kit	
PA03002-C262FJ	Carrier Ribbon Cable Ferrite Bead	Table 8-21 (page 738)
PA03002-C263FJ	Output Tray Flip-out	Table 8-20 (page 737)
PA03002-C264FJ	Panel Cover	Table 8-20 (page 737)
PA03002-C265FJ	Bearing for Feed Roller	Table 8-24 (page 744)
PA03002-C266FJ	Front Panel Frame Ground Spring	Table 8-20 (page 737)
PA03002-C267FJ	Junction PCA Cover	Table 8-21 (page 738)
PA03002-C269FJ	Brass Bushing for Pick Roller	Table 8-24 (page 744)

Table 8-32. Numerical Parts List (continued)

Part Number	Description	Table No. and Page
PA03002-C270FJ	Front Panel Cable Cover	Table 8-21 (page 738)
PA03002-C272FJ	Front Panel Frame Ground Plate	Table 8-20 (page 737)
PA03002-C273FJ	Front Panel Cable Clamp	Table 8-20 (page 737)
PA03002-C281FJ	TP Screw m3 x 6	Table 8-27 (page 748)
PA03002-C282FJ	TP Screw m3 x 8	Table 8-27 (page 748)
PA03002-C283FJ	Machine Screw w/washer m3 x 6	Table 8-28 (page 748)
PA03002-C284FJ	Machine Screw w/washer m3 x 8	Table 8-28 (page 748)
PA03002-C285FJ	Machine Screw w/washer m3 x 35	Table 8-28 (page 748)
PA03002-C286FJ	Machine Screw w/washer m4 x 8	Table 8-28 (page 748)
PA03002-C287FJ	Flat Head Screw m3 x6	Table 8-29 (page 749)
PM-3700	Copy Processor Card	Table 8-22 (page 740)

Index

Numerics

- 2 x 500-sheet input tray (trays 4 & 5)
 - adjustable foot tip 343
 - adjustment procedure 116
 - back cover 316
 - casters 342
 - controller PCA 334
 - diagnostics 621
 - dimensions 51
 - electrical specifications 53
 - front door (storage area) 341
 - front LED PCA 345
 - identification label 22
 - left cover 317
 - locating pins 344
 - main cable 338
 - messages 561
 - ordering 24
 - orientation 315
 - paper deck drive assembly 331
 - paper paths and components 160
 - parts and diagrams 698
 - pickup and feed system 162
 - pickup assembly 329
 - power supply 163, 337
 - printing from 159
 - removing and replacing 207
 - right cover 321
 - rollers 333
 - specifications 11, 51
 - storage paper tray 340
 - tray-size sensing PCA 335
 - verifying installation 589
 - vertical transfer unit 318
 - weight 51
- 2000-sheet input tray (tray 4)
 - adjustable foot 313
 - adjustment procedure 118
 - back cover 288
 - casters 312
 - clutches 156
 - controller PCA 296
 - diagnostic tests 617
 - dimensions 51
 - electrical specifications 53
 - features 155
 - front cover 287
 - front LED PCA assembly 298
 - identification label 22
 - LEDs 620
 - left cover 289
 - lifter operation 159
 - locating pins 311
 - main cable harness 294
 - main drive assembly 291
 - messages 557
 - motor test 617
 - motors 156
 - ordering 24
 - orientation 286
 - paper paths and components 155
 - paper quantity switch assembly 306
 - paper size switch assembly 306
 - paper tray 293
 - pickup and feed system 157
 - pickup assembly 300
 - power supply 159, 302
 - printing from 159
 - removing and replacing 207
 - right cover 290
 - rollers 304
 - sensor test 619
 - sensors 156
 - specifications 11, 51
 - stand-alone running test 617
 - switches 156
 - tension springs 310
 - troubleshooting 528, 529
 - verifying installation 589
 - vertical transfer unit (VTU) 308
 - weight 51
 - wiring diagram 649
- 2-sided printing 154
- 5-bin mailbox with stapler, *see* mailbox with stapler
- 7-bin tabletop mailbox 209
 - back cover 352
 - collator mode 168, 175
 - controller PCA 358
 - cover latch 383
 - diagnostics 625
 - dimensions 52
 - electrical specifications 54
 - empty bin sensor 367
 - face-down bins 364
 - face-up sensors PCA 372
 - face-up/diverter assembly (flipper) 375
 - flipper solenoid 380

- 7-bin tabletop mailbox (continued)
 - front cover 349
 - full bin and interlock sensor PCA 369
 - handle 381
 - identification label 22
 - latching mechanism 382
 - messages 565
 - modes 167
 - operation 166
 - ordering 24
 - orientation 348
 - paper paths and components 164
 - parts and diagrams 702
 - power supply 359
 - removing and replacing 209, 347
 - reversing mechanism 373
 - right door assembly (paper path cover) 360
 - short tray 7 378
 - solenoid reversing mechanism 379
 - specifications 12
 - stand
 - dimensions and weight 52
 - ordering 25
 - verifying installation 589
 - virtual stacker mode 168
 - weight 52
 - 8-bin mailbox
 - anticurl strings 402
 - attachment assembly 415
 - back cover 386
 - blind cover 389
 - casters 414
 - components 170
 - controller PCA 171, 400
 - delivery head assembly 173, 404
 - delivery head motor 393
 - diagnostic LED PCA 410
 - dimensions 48, 52
 - electrical specifications 53
 - features 170
 - flipper assembly 173, 390
 - front cover 386
 - identification label 22
 - input paper guide 396
 - interlock switch 409
 - LEDs 633
 - mailbox mode 174
 - messages 570
 - metal tape and housing assembly 398
 - motors 171
 - operating modes 170, 173
 - operation 173
 - ordering 24
 - orientation 385
 - paper bins 389
 - paper jams 530
 - paper path 170, 632
 - power box 28
 - power supply 388
 - power-on sequence 173, 631
 - receiving paper 173
 - removing and replacing 208
 - sensors 171
 - space requirements 48
 - specifications 12, 52
 - stand-alone diagnostics 630
 - stapler operation 177
 - status LED PCA 412
 - switches 171
 - testing 630
 - transport belt motor 394
 - troubleshooting 528, 530
 - verifying installation 589
 - virtual stacker mode 174
 - weight 52
 - wiring diagram 650
- A**
- AC access cover (Mopier) 218
 - AC power
 - distribution 132
 - troubleshooting 534
 - accessories
 - locations 23
 - ordering 24
 - see also paper-handling devices
 - user installable 204
 - verifying installation 589
 - acoustic emissions 54
 - ADF (HP Digital Copy 320)
 - belt 484
 - cover 452
 - duplex operation 194
 - lamp 479
 - lamp PCA 477
 - latch cap 451
 - loading
 - motor unit 483
 - paper path sensors 199
 - simplex operation 193
 - unit 487
 - adhesive labels, *see* labels
 - adjustable foot
 - 2 x 500-sheet input tray 343
 - 2000-sheet input tray 313
 - anticurl strings (8-bin mailbox) 402
 - attachment assembly (8-bin mailbox) 415
 - attention light 60
 - automatic document feeder, *see* ADF

B

- back PCA (HP Digital Copy 320) 474
- back plate (stapler) 419
- background scatter 604
- bed assembly (stapler) 425
- bins
 - configuring
 - 7-bin tabletop mailbox 167
 - 8-bin mailbox 173
 - specifications 11, 52
- bins (removing and replacing)
 - 7-bin tabletop mailbox 364
 - 8-bin mailbox 389
- black lines 602
- black page 599
- blank page
 - entire 599
 - middle of page 611
 - partial 610
- bubble print 609
- button functions (HP Digital Copy 320) 98

C

- cable harness (2000-sheet input tray) 294
- cables
 - c-link
 - input and output 180
 - troubleshooting 523
 - main (2 x 500-sheet input tray) 338
 - ordering 27
 - parallel 184
- calibration (HP Digital Copy 320) 126
- cancel job key 59
- capacity of paper trays 11
- card cage (HP Digital Copy 320) 470
- carrier belt and motor (HP Digital Copy 320) 509
- carrier unit (HP Digital Copy 320) 497
- carrier unit lamp (HP Digital Copy 320) 494
- cartridge slots 3
- casters
 - 2 x 500-sheet input tray 342
 - 2000-sheet input tray 312
 - 8-bin mailbox 414
- cleaning
 - Mopier and accessories 112
 - spilled toner 114
 - toner cartridge drum 142
- cleaning (HP Digital Copy 320) 120
- clutches
 - 2000-sheet input tray 156
 - diagram 640
 - drive signals 137
 - locations 150
- cold reset

- paper size 61, 85, 88
- performing 62
- collator mode
 - 7-bin tabletop mailbox 168, 175
- communication (HP Digital Copy 320) 653
- communication (Mopier) 198
- communication channels 198
- communications link, *see* cables, c-link
- compressed print 611
- configuration menu 75
- configuration page
 - printing 89
 - troubleshooting 589
- consumables 513
- control panel
 - default settings 60
 - display 65
 - keys 58
 - language 62
 - layout 58
 - lights 59
 - overriding settings 60
 - removing and replacing 215
 - troubleshooting 538
- control panel menus 65
- configuration 75
- EIO 82
- I/O 80
- information 67
- map 588
- paper handling 68
- print quality 70
- printing 72
- resets 84
- service mode 85

- control PCA (HP Digital Copy 320) 469
- controller PCA
 - 2 x 500-sheet input tray 334
 - 2000-sheet input tray 296
 - 7-bin tabletop mailbox 358
 - 8-bin mailbox 171, 400
 - DC (printer) 261
 - stapler 421
- copy connect cable (installing) 435
- copy connect EIO board (installing in Mopier) 434
- copy module, *see* HP Digital Copy 320
- copy processor board (HP Digital Copy 320)
 - LED test 665
 - power-up 189
 - removing and replacing 464

- covers
 - 2 x 500-sheet input tray
 - back 316
 - front top 324
 - left 317
 - right 321
 - 2000-sheet input tray
 - back 288
 - front 287
 - left 289
 - right 290
 - 7-bin tabletop mailbox
 - back 352
 - front 349
 - latch 383
 - top 354
 - 8-bin mailbox
 - back 386
 - blind 389
 - front 386
 - cleaning 114
 - HP Digital Copy 320 445
 - Mopier
 - AC access 218
 - back 219
 - front 220
 - left lower 222
 - top 223
 - stapler
 - top 424
 - curl (paper) 533
- D**
 - daisy chain connections 523
 - data light 59
 - DC controller PCA
 - diagrams 641
 - functions 137
 - removing 261
 - DC power 131
 - declaration of conformity
 - HP Digital Copy 320 40
 - HP Mopier 320 39
 - default settings
 - control panel 60
 - restoring 84
 - delivery head assembly (8-bin mailbox)
 - 173, 404
 - delivery head motor (8-bin mailbox) 393
 - delivery unit (face-down output bin)
 - fan 238
 - removing 226
 - density calibration adjustment (HP Digital Copy 320) 128
 - diagnostic LED PCA (8-bin mailbox) 410
 - diagnostics on paper-handling devices
 - 617
 - diagrams
 - how to use 674
 - list 638
 - dimensions of Mopier and accessories 47
 - dimensions of Mopier and paper-handling devices 51
 - dimensions of printer and accessories 52
 - DIMM *see* memory
 - DIMM, *see* memory
 - DIP switches 619
 - display checks (HP Digital Copy 320) 653
 - diverter assembly
 - 7-bin tabletop mailbox 375
 - door 230
 - removing and replacing 229
 - document holding pad (HP Digital Copy 320) 445
 - documentation 28
 - door assembly
 - 7-bin tabletop mailbox 360
 - printer right lower 231
 - downloading firmware (HP Digital Copy 320) 108
 - draft mode, *see* EconoMode
 - drive assembly (2000-sheet input tray)
 - 291
 - driver
 - overriding control panel settings 60
 - troubleshooting 527
 - dropouts 602
 - drum
 - cleaning 142
 - conditioning 143
 - rotation functional check 615
 - duplexer
 - dimensions 52
 - memory requirements 31
 - messages 579
 - operation 154
 - ordering 24
 - paper paths and components 150
 - removing and replacing 206
 - specifications 12
 - speed 2
 - standard or optional 3
 - verifying installation 589
 - weight 52
 - duty cycle 3
- E**
 - EconoMode 136
 - EDO DIMMs, *see* memory
 - EEPROM (HP Digital Copy 320) 471

- 8-bin mailbox
 - anticurl strings 402
 - attachment assembly 415
 - back cover 386
 - blind cover 389
 - casters 414
 - components 170
 - controller PCA 171, 400
 - delivery head assembly 173, 404
 - delivery head motor 393
 - diagnostic LED PCA 410
 - dimensions 48, 52
 - electrical specifications 53
 - features 170
 - flipper assembly 173, 390
 - front cover 386
 - identification label 22
 - input paper guide 396
 - interlock switch 409
 - LEDs 633
 - mailbox mode 174
 - messages 570
 - metal tape and housing assembly 398
 - motors 171
 - operating modes 170, 173
 - operation 173
 - ordering 24
 - orientation 385
 - paper bins 389
 - paper jams 530
 - paper path 170, 632
 - power box 28
 - power supply 388
 - power-on sequence 173, 631
 - receiving paper 173
 - removing and replacing 208
 - sensors 171
 - space requirements 48
 - specifications 12, 52
 - stand-alone diagnostics 630
 - stapler operation 177
 - status LED PCA 412
 - switches 171
 - testing 630
 - transport belt motor 394
 - troubleshooting 528, 530
 - verifying installation 589
 - virtual stacker mode 174
 - weight 52
 - wiring diagram 650
- EIO cards
 - ordering 28
 - standard 3
 - status 89
- EIO menu 82
- electrical specifications 53
- electrostatic discharge sensitive (ESD) 202
- EMI statement for Korea 43
- engine test
 - microswitch 138
 - troubleshooting 537
- envelope feeder
 - dimensions 52
 - messages 564
 - ordering 24
 - paper paths and components 150
 - printing from 154
 - removing and replacing 206
 - specifications 12
 - verifying installation 589
 - weight 52
- envelopes
 - guidelines 13
 - paper jams 530
 - troubleshooting 529, 531
- environment
 - operating 46
 - requirements 50
- environmental product stewardship 35
- error messages, *see* messages
- ESD precautions 202
- event log
 - clearing 85
 - troubleshooting 538
 - using 538
- exchange program 513
- exhaust
 - fan 1 (laser/scanner) 234
 - fan 2 (lvps) 236
 - fan 4 (delivery unit) 238
- F**
- face-down bins
 - 7-bin tabletop mailbox 364
 - 8-bin mailbox 389
 - delivery unit 226
 - specifications 11
- face-up solenoid assembly 281
- face-up/diverter assembly (flipper) (7-bin tabletop mailbox) 375
- factory settings 60
- fading print 530, 600
- fan
 - fan 1 (laser/scanner) 234
 - fan 2 (lvps) 236
 - fan 3 (formatter) 237
 - fan 4 (delivery unit) 238
 - fan 5 (tray 1 intake) 239
 - HP Digital Copy 320 472
 - locations 150
 - motors 138

- faulty registration 608
 - FCC statement 34
 - feeder assembly 248
 - feet (HP Digital Copy 320) 502
 - felt pad (HP Digital Copy 320) 501
 - field replaceable units, ordering 512
 - finisher components 175
 - Finland laser statement 43
 - firmware (HP Digital Copy 320) 108
 - 5-bin mailbox with stapler, *see* mailbox with stapler
 - flash DIMMs (ordering) 27
 - see also* memory
 - flashing light 59
 - flatbed cover assembly (HP Digital Copy 320) 448
 - flatbed operation (HP Digital Copy 320) 194
 - flipper assembly
 - 7-bin tabletop mailbox 375
 - 8-bin mailbox 390
 - fonts
 - internal 3
 - ordering 27
 - foot
 - 2 x 500-sheet input tray 343
 - 2000-sheet input tray 313
 - HP Digital Copy 320 502
 - formatter assembly
 - fan 237
 - function 134
 - part locations 7
 - removing 250, 251
 - retaining settings 87
 - frame ground spring (HP Digital Copy 320) 503
 - front lamp PCA (HP Digital Copy 320) 504
 - front LED PCA
 - 2 x 500-sheet input tray 345
 - 2000-sheet input tray 298
 - front panel (HP Digital Copy 320)
 - brackets 460
 - frame ground spring 488
 - installing overlay 90
 - layout 91
 - removing and replacing 454
 - ribbon cable 457, 507
 - using 90
 - front top cover (2 x 500-sheet input tray) 324
 - FRUs, *see* field replaceable units
 - FTP technical assistance 33
 - full bin sensor PCA (7-bin tabletop mailbox) 369
 - functional block diagram 130
 - functional overview (HP Digital Copy 320) 185
 - fusing assembly
 - cleaning 114
 - removing 252
 - fusing images
 - about 149
 - troubleshooting 531
- G**
- gear assembly 256
 - glass plate assembly (HP Digital Copy 320) 490
 - go key 58
- H**
- half self test functional check 614
 - handle (7-bin tabletop mailbox) 381
 - hard disk
 - about 30
 - ordering 27
 - removing and replacing 205
 - verifying installation 589
 - hardware table 212
 - engine 212
 - HP Digital Copy 320 437
 - Hardware Technical Support Center (HTSC) 33
 - high voltage power supply
 - check 615
 - contacts 133, 140
 - distribution 133
 - removing and replacing 269
 - hinges (stapler) 427
 - home position sensor (HP Digital Copy 320) 492
 - HP ASAP (Automated Support Access Program) 32
 - HP Digital Copy 320
 - ADF belt 484
 - ADF cover 452
 - ADF duplex operation 194
 - ADF lamp 479
 - ADF lamp PCA 477
 - ADF latch cap 451
 - ADF motor unit 483
 - ADF simplex operation 193
 - ADF unit 487
 - alphabetical parts list 750
 - assembly locations 735
 - back PCA 474
 - boot errors 655
 - Boot Up Icon Conditions 666
 - button functions 98
 - calibrating 126
 - card cage 470

HP Digital Copy 320 (continued)

- carrier belt and motor 509
- carrier unit 497
- carrier unit lamp 494
- cleaning 120
- cleaning ADF and glass 121
- complete optics cleaning 124
- configurations 9
- context sensitive help 97
- control PCA 469
- copy processor
 - function 187
 - layout 187
- copy processor board
 - LED test 665
 - power-up 189
 - removing and replacing 464
- default configurations 97
- density calibration adjustment 128
- display and communication
 - troubleshooting 653
- document holding pad 445
- document quality 18
- downloading firmware 108
- EEPROM 471
- equipment errors 655
- error messages 654
- fan 472
- features 2
- features of the copy module 4
- feet 502
- felt pad 501
- flatbed 104
- flatbed cover assembly 448
- flatbed operation 194
- frame ground spring 503
- front lamp PCA 504
- front panel
 - installing overlay 90
 - layout 91
 - removing and replacing 454
 - using 90
- front panel brackets 460
- front panel frame ground spring 488
- front panel ribbon cable 457, 507
- functional overview 185
- glass plate assembly 490
- hardware table 437
- home position sensor 492
- image quality 661
- installing 430
- junction PCA and cover 505
- LED Assembly PCA 486
- LED functions 98
- loading ADF
- lubricating 124
- maintenance 126
- media selection guidelines 17
- menu tabs 92
- numerical parts list 754
- offline test 667
- offset adjustment 128
- optical unit 475
- orientation 439
- output tray 447
- output tray brackets 489
- output tray flip-out 447
- panel cover 459
- paper chute flip-out 446
- paper path 660
- paper path sensors 199
- parts 8
- parts and diagrams 735
- performing maintenance 440
- pick roller assembly 441
- power on checks 652
- power supply 465, 473
- power-up 191
- RFI cover 467
- sensor unit assembly 480
- sensors 667
- separation pad assembly 440
- service mode 105
- service mode tests 671
- settings and defaults 100
- shipping lock 431
- skins 445
- specifications 55
- stand (installing) 430
- start button LED 99
- status bar 91
- temporary errors 658
- testing 664
- troubleshooting 651
- upper cover 462
- vertical magnification adjustment 128
- y power cord 436

HP distribution center 512

HP FIRST (Fax Information Retrieval Support Technology) 32

HP JetDirect print server card, *see* EIO cards

HP JetDirect Print Server Software Installation Guide 28

HP LaserJet Printer Family Paper Specification Guide 28

HP reseller sales and service support 33

HP resource manager 107

HP support line 512

HTSC, *see* Hardware Technical Support Center

humidity 50
hvps, *see* high voltage power supply

I

I/O
 menu 80
 troubleshooting 523
identification 22
image formation
 block diagram 139
 developing 146
 fusing 149
 system 139
 transferring 148
 writing 144
image path 196
image quality
 HP Digital Copy 320 661
 Mopier 597
image skew 529, 608
images per month 3
indicator lights 59
information menu 67
input paper guide (8-bin mailbox) 396
interface
 accessories 27
 standard 3
interlock sensor PCA (7-bin tabletop mailbox) 369
interlock switch (8-bin mailbox) 409
internet technical assistance 33
item key 59

J

job interrupt 198
job separator mode
 7-bin tabletop mailbox 168
junction PCA and cover (HP Digital Copy 320) 505

K

keys on control panel 58
Korean EMI statement 43

L

labels
 adhesive 14
 paper jams 530
 printer identification 22
language on control panel 62
languages (personalities)
 removing and replacing 204
 standard printer 3
 status 89
 verifying installation 589

laser statement for Finland 43

laser/scanner
 assembly 254
 drive 137
 fan 234
 motors 138
latching mechanism (7-bin tabletop mailbox) 382
layout
 copy processor (HP Digital Copy 320) 187

LED

2 x 500-sheet input tray front LED PCA 345
2000-sheet input tray 620
2000-sheet input tray front LED PCA 298
7-bin tabletop mailbox LED PCA 371
8-bin mailbox 633
 diagnostic 410
 status 412
Assembly PCA (HP Digital Copy 320) 486
HP Digital Copy 320
 functions 98
 start button LED 99
 interpreting status 620, 630, 633
 troubleshooting 624
left output bin specifications 11
light print 530, 600
lights on control panel 59
lines
 black 602
 edge of paper 606
 white 610
LocalTalk cable 27
locating pins
 2 x 500-sheet input tray 344
 2000-sheet input tray 119, 311
low voltage power supply
 distribution system 131
 removing and replacing 270
lvps, *see* low voltage power supply

M

Macintosh network cable kit (ordering) 27
mailbox mode
 7-bin tabletop mailbox 167
 8-bin mailbox 174
mailbox with stapler
 electrical specifications 53
 identification label 22
 operation 177
 ordering 24
 paper jams 530
 removing and replacing 208

- mailbox with stapler (continued)
 - specifications 12
 - troubleshooting 530
 - verifying installation 589
 - wiring diagram 646
- main cable harness (2000-sheet input tray) 294
- main drive assembly (2000-sheet input tray) 291
- main gear assembly 256
- maintenance
 - HP Digital Copy 320 126
 - kit, ordering 28
 - preventative 115
 - setting count 87, 250
- manuals 28
- mass storage, *see* hard disk drive
- media selection guidelines (HP Digital Copy 320) 17
- media separation 148
- media, *see* paper
- memory
 - installing
 - ordering 27
 - removing and replacing 204
 - requirements 30
 - standard 3
 - status 89
 - verifying installation 589
- menu key 58
- menu map page 588
- menu tabs (HP Digital Copy 320) 92
- menus, *see* control panel menus
- messages
 - 2 x 500-sheet input tray 561
 - 2000-sheet input tray 557
 - 7-bin tabletop mailbox 565
 - 8-bin mailbox 570
 - duplexer 579
 - engine 545
 - envelope feeder 564
 - HP Digital Copy 320 654
 - paper handling controller 580
 - stapler 576
- metal tape and housing assembly (8-bin mailbox) 398
- minus key 59
- model number 22
- monthly usage 3
- Mopier
 - communication 198
 - dimensions 47, 51, 52
 - electrical specifications 53
 - features 2
 - paper paths and components 150
 - part locations 673

- power-up 192
- specifications 51
- testing 89
- motor
 - 2000-sheet input tray 156
 - 7-bin tabletop mailbox reversing mechanism 373
 - 8-bin mailbox 171
 - 8-bin mailbox transport belt 394
 - assembly 259
 - diagram 640
 - fan 1 235
 - fan 3 237
 - locating 150
 - main motor assembly 259
 - operation 138
 - test 617
 - verifying functionality 617
- multi-purpose tray, *see* tray 1

N

- network cards, *see* EIO cards
- network troubleshooting 523
- noise
 - emissions 54
 - troubleshooting 528

O

- offline test (HP Digital Copy 320) 667
- offset adjustment (HP Digital Copy 320) 128
- operating
 - environment 46
 - overview 57
- optical unit (HP Digital Copy 320) 475
- options, *see* accessories
- ordering parts 512, 674
- output paper sensor PCA 262
- output tray (HP Digital Copy 320) 447
- output tray brackets (HP Digital Copy 320) 489
- output tray flip-out (HP Digital Copy 320) 447
- overcurrent/overvoltage protection 132
- overhead transparencies, *see* transparencies
- overriding control panel settings 60

P

- page count
 - setting 85, 87, 250
 - troubleshooting 529
- page skew 529, 608
- pages per minute (ppm) 2
- panel cover (HP Digital Copy 320) 459

- paper
 - delivery 173
 - ordering 26
 - sizes and memory requirements 31
 - specifications (HP Digital Copy 320) 17
 - specifications (Mopier and paper-handling devices) 11, 13
 - specifications guide 28
 - storing 15
- paper chute flip-out (HP Digital Copy 320) 446
- paper deck drive assembly (2 x 500-sheet input tray)
 - operation 158, 162
 - removing and replacing 331
- paper guide (8-bin mailbox) 396
- paper handling controller messages 580
- paper handling menu 68
- paper input unit (PIU)
 - removing and replacing 260
 - sensor 277
- paper jams
 - 8-bin mailbox or mailbox with stapler 530
 - detection 182
 - troubleshooting 581, 582, 585
- paper motion monitoring and control 137
- paper path
 - cleaning 113
 - HP Digital Copy 320 660
 - sensors (HP Digital Copy 320) 199
 - test 89, 584, 632
 - troubleshooting 581
- paper path cover (7-bin tabletop mailbox) 360
- paper size
 - cold reset 61, 85, 88
 - PCA 266
- paper size switches
 - 2 x 500-sheet input tray 162
 - 2000-sheet input tray 306
 - trays 2 & 3 153
- paper source default 61
- paper tray capacities 11
- paper weight equivalence table 16
- paper-handling devices
 - diagnostics 617
 - dimensions 51
 - locations 23
 - ordering 24
 - parts and diagrams 676
 - specifications 11, 51
 - verifying installation 589
- parallel cables
 - ordering 27
 - pin configuration 184
 - specifications 184
- parts
 - diagrams 673
 - ordering 512, 674
- PCL
 - fonts 3
 - memory requirements 31
- PCL 5/PJL Technical Reference Documentation Package* 28
- PCL 5e and PCL 6 3
- personalities, *see* languages
- phone numbers
 - ordering parts 512
 - technical assistance 32
- PhoneNET cable 27
- photosensitive drum 141
- pick roller assembly (HP Digital Copy 320) 441
- pickup assembly
 - 2 x 500-sheet input tray 329
 - 2000-sheet input tray 300
 - tray 1 244
- pins (locating)
 - 2 x 500-sheet input tray 344
 - 2000-sheet input tray 119, 311
- PIU, *see* paper input unit
- plus key 59
- PM kit, *see* preventative maintenance
- PostScript Level 2 emulation (PS)
 - fonts 3
 - memory requirements 31
- power box 28
- power distribution system 131
- power rating 22
- power save mode
 - description 134
 - electrical specifications 53
- power supply
 - 2 x 500-sheet input tray 163, 337
 - 2000-sheet input tray 302
 - 7-bin tabletop mailbox 359
 - 8-bin mailbox 388
 - HP Digital Copy 320 465, 473
 - operation (2000-sheet input tray or 2 x 500-sheet input tray 159
 - see also* high voltage power supply or low voltage power supply
- power troubleshooting (HP Digital Copy 320) 652
- power-up sequence test 631
- ppm, *see* pages per minute

- preventative maintenance
 - about 115
 - count 87, 250
 - ordering kit 28
- print job interrupt 198
- print quality
 - cleaning Mopier 112
 - menu 70
 - troubleshooting 597
- print settings
 - density adjustment 133
 - speed 2
- printer stand (7-bin tabletop mailbox)
 - dimensions and weight 52
 - ordering 25
- printer, *see* Mopier
- printing menu 72
- printing supplies 26
- product ID (HP Mopier 320) 192
- PS, *see* PostScript Level 2 emulation
- PS1, *see* registration sensor
- PS2, *see* paper input unit sensor

R

- ready light 59
- recycling toner cartridges 514
- registration assembly
 - cleaning roller 113
 - removing and replacing 271
 - sensor 279
- registration faulty 608
- regulatory information 22
- remanufactured assemblies 513
- removal and replacement strategy 202
- repair process 512
- repetitive defects
 - ruler 613
 - troubleshooting 605
- resets menu 84
- resetting printer 62
- resolution enhancement (REt) 135
- reversing mechanism (7-bin tabletop mailbox)
 - motor 373
 - solenoid 379
- RFI cover (HP Digital Copy 320) 467
- rollers
 - 2 x 500-sheet input tray 333
 - 2000-sheet input tray
 - pickup, feed, and separation 304
 - separation roller 158
 - cleaning, pickup, and feed 114
 - HP Digital Copy 320 441
 - transfer 282
 - tray 1 274
 - trays 2 & 3 276

S

- scanner
 - see* HP Digital Copy 320
 - see* laser/scanner
- screws hardware table
 - HP Digital Copy 320 437
 - Mopier 212
- SDRAM DIMMs, ordering 27
 - see also* memory
- select key 59
- self test, *see* configuration page
- sensor unit assembly (HP Digital Copy 320) 480
- sensors
 - 2000-sheet input tray 156
 - 7-bin tabletop mailbox
 - empty bin 367
 - face-up 372
 - full bin and interlock 369
 - 8-bin mailbox 171
 - PSEntry 173
 - PSFaceUp 173
 - activating 619
 - diagram 639
 - HP Digital Copy 320 480, 667
 - locating 150
 - output paper 262
 - paper input unit (PIU) 277
 - registration 279
 - testing 619
- separation pad (Mopier)
 - cleaning 114
 - tray 1 275
- separation pad assembly (HP Digital Copy 320) 440
- serial number
 - location 22
 - setting 85, 87, 250
 - troubleshooting 529
- server troubleshooting 527
- service approach 512
- service mode
 - HP Digital Copy 320 105
 - Mopier 85
- service mode tests (HP Digital Copy 320) 671
- 7-bin tabletop mailbox
 - back cover 352
 - collator mode 168, 175
 - controller PCA 358
 - cover latch 383
 - diagnostics 625
 - dimensions 52
 - electrical specifications 54
 - empty bin sensor 367
 - face-down bins 364

- 7-bin tabletop mailbox (continued)
 - face-up sensors PCA 372
 - face-up/diverter assembly (flipper) 375
 - flipper solenoid 380
 - front cover 349
 - full bin and interlock sensor PCA 369
 - handle 381
 - identification label 22
 - latching mechanism 382
 - messages 565
 - modes 167
 - operation 166
 - ordering 24
 - orientation 348
 - paper paths and components 164
 - parts and diagrams 702
 - power supply 359
 - removing and replacing 209, 347
 - reversing mechanism 373
 - short tray 7 378
 - solenoid reversing mechanism 379
 - specifications 12
 - stand
 - dimensions and weight 52
 - ordering 25
 - top cover 354
 - verifying installation 589
 - virtual stacker mode 168
 - weight 52
 - short tray 7 (7-bin tabletop mailbox) 378
 - site requirements 45
 - skew 529, 608
 - skins (HP Digital Copy 320) 445
 - slides, *see* transparencies
 - SME, *see* Support Materials Europe
 - smearred toner 603
 - SMO, *see* Support Materials Organization
 - solenoids
 - 7-bin tabletop mailbox
 - flipper 380
 - reversing mechanism 379
 - diagram 640
 - face-up assembly (printer) 281
 - locations 150
 - space requirements 47
 - specifications
 - acoustic emissions 54
 - electrical 53
 - ordering guide 28
 - paper 13
 - paper trays, bins, and accessories 11
 - printer and paper-handling devices 51
 - specks 604
 - speed (pages per minute) 2
 - stacker mode
 - 7-bin tabletop mailbox 168
 - 8-bin mailbox 174
 - stand (7-bin tabletop mailbox)
 - dimensions and weight 52
 - ordering 25
 - stapler
 - back plate 419
 - controller PCA 421
 - dimensions 52
 - hinges 427
 - messages 576
 - non-HP cartridges 514
 - operation 177
 - paper jams 530
 - paper paths and components 175
 - parts and diagrams 691, 693, 713
 - removing and replacing 416
 - stapler bed assembly 425
 - top cover 424
 - verifying installation 589
 - weight 52
 - status bar (HP Digital Copy 320) 91
 - storage paper tray (2 x 500-sheet input tray) 340
 - supplies (ordering information) 24
 - Support Materials Europe (SME) 512, 674
 - Support Materials Organization (SMO) 512, 674
 - switches
 - 2 x 500-sheet input tray, paper size 162
 - 2000-sheet input tray 156
 - 8-bin mailbox 171
 - detecting tray 159
 - diagram 639
 - function 157, 162
 - paper quantity 157
 - paper size 157
 - trays 2 & 3 (paper size) 153
- T**
 - technical assistance 32
 - temperature (printer) 50
 - tension springs (2000-sheet input tray) 310
 - test
 - HP Digital Copy 320 664
 - Mopier 89
 - paper-handling devices 617
 - printer 584, 589
 - timing (printer) 182

- toner cartridge
 - cleaning spills 114
 - contacts 133, 140
 - detection 133
 - image formation 140
 - life expectancy 513
 - ordering 26
 - recycling 514
 - refilled 514
 - troubleshooting 598
 - warranty 514
 - weight 51
- toner smear 603
- tools 203
- transfer roller assembly
 - cleaning 114
 - removing and replacing 282
- transparencies
 - guidelines 15
 - paper jams 530
- transport belt motor (8-bin mailbox) 394
- tray 1
 - pickup assembly 244
 - printing from 153
 - removing and replacing 241
 - specifications 11
- tray 7 (7-bin tabletop mailbox) 378
- tray selection
 - default paper source 61
 - troubleshooting 529, 531
- trays 2 & 3
 - adjustment procedure 116
 - pickup motor 138
 - printing from 153
 - removing and replacing 284
 - specifications 11
- trays 4 & 5 (removing and replacing) 327
- tray-size sensing PCA (2 x 500-sheet input tray) 335
- troubleshooting
 - c-link cables 523
 - communication 523
 - control panel 538
 - diagnostic tools 617, 630
 - drum rotation functional check 615
 - engine test 537
 - event log 538
 - general 528
 - half self test functional check 614
 - high voltage power supply check 615
 - HP Digital Copy 320 651
 - image defects 599
 - image quality 597
 - interface 525
 - paper curl 533
 - paper jams 581, 582, 585
 - paper-handling devices 617
 - power-on 534
 - print quality 597
 - printer stops/hangs 530
 - process 515
 - toner cartridge 598
- 2 x 500-sheet input tray (trays 4 & 5)
 - adjustable foot tip 343
 - back cover 316
 - casters 342
 - controller PCA 334
 - diagnostics 621
 - dimensions 51
 - electrical specifications 53
 - front door (storage area) 341
 - front LED PCA 345
 - front top cover 324
 - identification label 22
 - left cover 317
 - locating pins 344
 - main cable 338
 - messages 561
 - ordering 24
 - orientation 315
 - paper deck drive assembly 331
 - paper paths and components 160
 - parts and diagrams 698
 - pickup and feed system 162
 - pickup assembly 329
 - power supply 163, 337
 - printing from 159
 - removing and replacing 207
 - right cover 321
 - rollers 333
 - specifications 11, 51
 - storage paper tray 340
 - tray-size sensing PCA 335
 - verifying installation 589
 - vertical transfer unit 318
 - weight 51
- 2-sided printing 154
- 2000-sheet input tray (tray 4)
 - adjustable foot 313
 - adjustment procedure 118
 - back cover 288
 - casters 312
 - clutches 156
 - controller PCA 296
 - diagnostic tests 617
 - dimensions 51
 - electrical specifications 53
 - features 155
 - front cover 287
 - front LED PCA assembly 298
 - identification label 22
 - LEDs 620

2000-sheet input tray (tray 4) (continued)
left cover 289
lifter operation 159
locating pins 311
main cable harness 294
main drive assembly 291
messages 557
motor test 617
motors 156
ordering 24
orientation 286
paper paths and components 155
paper quantity switch assembly 306
paper size switch assembly 306
paper tray 293
pickup and feed system 157
pickup assembly 300
power supply 159, 302
printing from 159
removing and replacing 207
right cover 290
rollers 304
sensor test 619
sensors 156
specifications 11, 51
stand-alone running test 617
switches 156
tension springs 310
troubleshooting 528, 529
verifying installation 589
vertical transfer unit (VTU) 308
weight 51
wiring diagram 649
typefaces, *see* fonts

wiring diagram
2000-sheet input tray 649
8-bin mailbox 650
mailbox with stapler 646
printer, *see foldout pages*
world wide web technical assistance 33

Y

y power cord (installing) 436

U

upper cover (HP Digital Copy 320) 462

V

value key 59
VCCI statement (Japan) 42
vertical magnification adjustment (HP
Digital Copy 320) 128
vertical transfer unit
2 x 500-sheet input tray 318
2000-sheet input tray 308
virtual stacker mode
7-bin tabletop mailbox 168
8-bin mailbox 174

W

white lines 610
white page 599

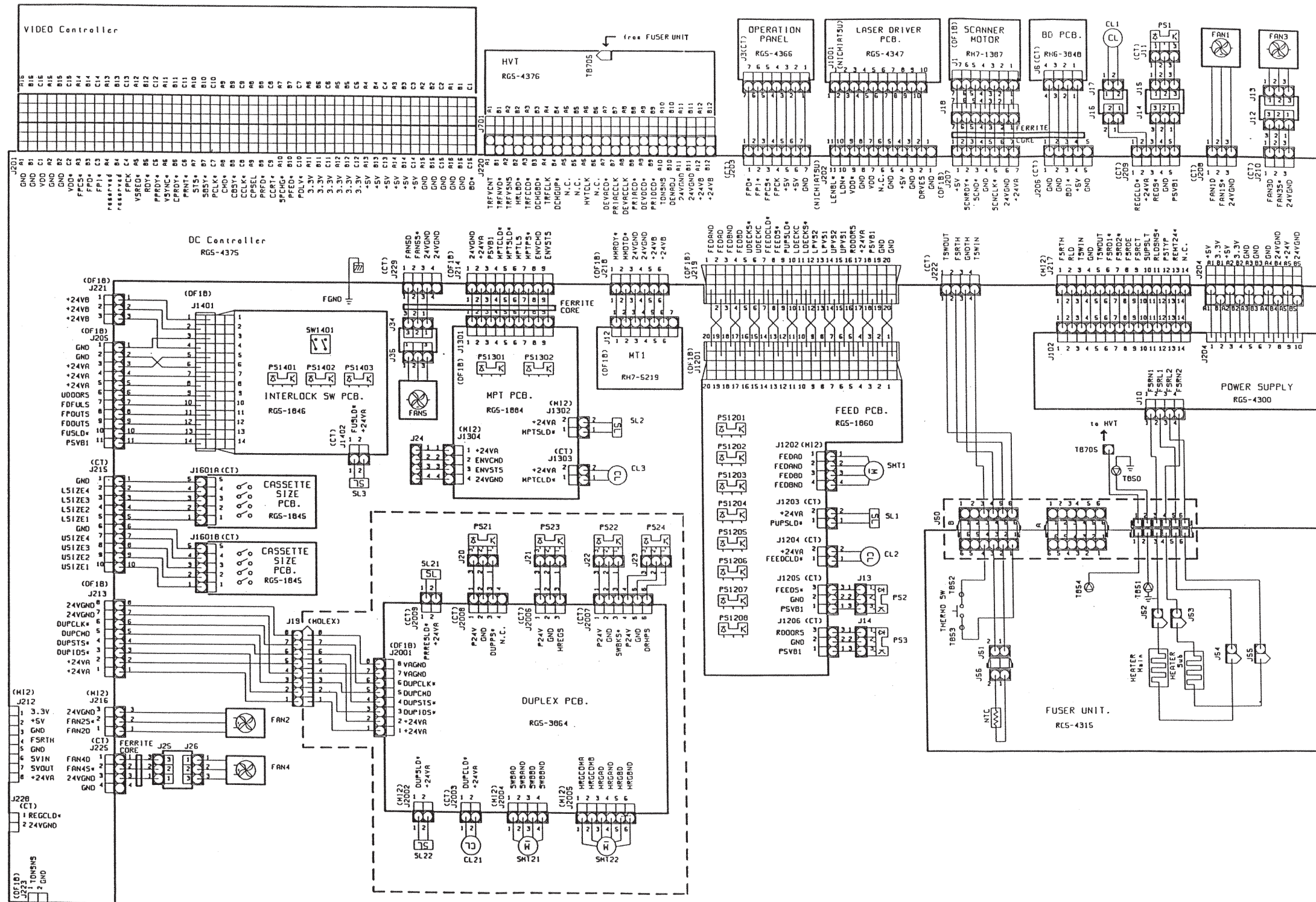

HP Digital Copy 320 - Keeping Track of Screws

Use the table on the other side of this page to keep track of screws as you remove and replace parts on the HP Digital Copy 320.

- 1 Remove this page from the manual.
- 2 Tape an ice cube tray or other 14-compartment container over the blank squares. Place screws in the compartment corresponding to each part

or

Place this page on a level surface. Place screws in the blank squares corresponding to each part.

Pick Roller Cover 2 Thumb Screws	Flat Bed Cover Assembly 1 Thumb Screw	ADF Latch Cap and 1 screw	ADF Cover 2 Screws	Front Panel 1 screw	Panel Cover 2 Screws	Upper Cover 4 Screws
Pick Roller 4 Brass Bushings				Cable Grounding Clamp & Cable Protector 3 Screws	Front Panel Brackets 3 Brass Screws with Washers	
Power Supply and Main Board Tray 2 Brass Screws	RFI Cover 7 Screws	Control PCA 7 Screws	Card Cage 4 Screws	Fan 2 Screws	Power Supply 6 Screws	Back PCA 2 Screws

HP Digital Copy 320 - Keeping Track of Screws

Use the table on the other side of this page to keep track of screws as you remove and replace parts on the HP Digital Copy 320.

- 1 Remove this page from the manual.
- 2 Tape an ice cube tray or other 14-compartment container over the blank squares. Place screws in the compartment corresponding to each part

or

Place this page on a level surface. Place screws in the blank squares corresponding to each part.

Optical Unit Tie-down and 1 Screw	ADF Lamp 2 Screws	Sensor Unit Assembly 4 Screws	ADF Motor Unit 2 Screws	LED Assembly PCA 3 Screws	ADF Unit 4 Screws	Front Panel Frame Ground Spring 2 Screws
Output Tray Brackets and Screws (1 each)	Glass Plate Assembly 2 Screws	Carrier Unit Lamp 1 Screw	Carrier Unit 1 Screw	Front Lamp PCA 1 Screw	Junction PCA and Cover 2 Screws	Carrier Belt and Motor 3 Screws



Copyright© 1998
Hewlett-Packard Co.
Printed in USA

Manual Part No.
C4229-90911



Printed on at least
50% Total Recycled Fiber with
at least 10% Post-Consumer Paper



C4229-90911